

# City of Fridley

## 2019 General Specifications and Standard Detail Plates for Road and Utility Construction



City of Fridley, Minnesota  
6431 University Avenue N.E.  
City of Fridley, Minnesota

June 14, 2019

**Division 00**

Procurement and Contracting Requirements Group

**2019 City of Fridley General Specifications and  
Standard Detail Plates for Road and Utility  
Construction**

**City of Fridley, Minnesota**

6431 University Avenue N.E.

Fridley, MN 55432

**GENERAL SPECIFICATIONS AND  
STANDARD DETAIL PLATES FOR STREET AND UTILITY CONSTRUCTION**

**City of Fridley, Minnesota  
6431 University Avenue  
Fridley, MN 55432**



**June 14, 2019**

**CITY OF FRIDLEY  
GENERAL SPECIFICATIONS AND  
STANDARD DETAIL PLATES FOR ROAD  
AND UTILITY CONSTRUCTION**

**Fridley, Minnesota  
June 2019**

**I hereby certify that these plans and specifications were prepared by me or under my direct supervision, and that I am a duly Licensed Professional Engineer under the laws of the State of Minnesota.**

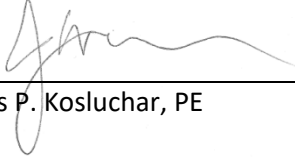
  
\_\_\_\_\_  
James P. Kosluchar, PE

Registration No. 26460

Date: 4/20/2018  
\_\_\_\_\_

This document has important legal consequences; consultation with an attorney is encouraged with respect to its use or modification. This document should be adapted to the particular circumstances of the contemplated Project and the controlling Laws and Regulations.

## STANDARD GENERAL CONDITIONS OF THE CONSTRUCTION CONTRACT

Prepared by



Issued and Published Jointly by



These General Conditions have been prepared for use with the Agreement Between Owner and Contractor for Construction Contract (EJCDC® C-520, Stipulated Sum, or C-525, Cost-Plus, 2013 Editions). Their provisions are interrelated and a change in one may necessitate a change in the other.

To prepare supplementary conditions that are coordinated with the General Conditions, use EJCDC's Guide to the Preparation of Supplementary Conditions (EJCDC® C-800, 2013 Edition). The full EJCDC Construction series of documents is discussed in the Commentary on the 2013 EJCDC Construction Documents (EJCDC® C-001, 2013 Edition).

Copyright © 2013:

National Society of Professional Engineers  
1420 King Street, Alexandria, VA 22314-2794  
(703) 684-2882  
[www.nspe.org](http://www.nspe.org)

American Council of Engineering Companies  
1015 15th Street N.W., Washington, DC 20005  
(202) 347-7474  
[www.acec.org](http://www.acec.org)

American Society of Civil Engineers  
1801 Alexander Bell Drive, Reston, VA 20191-4400  
(800) 548-2723  
[www.asce.org](http://www.asce.org)

The copyright for this document is owned jointly by the three sponsoring organizations listed above. The National Society of Professional Engineers is the Copyright Administrator for the EJCDC documents; please direct all inquiries regarding EJCDC copyrights to NSPE.

NOTE: EJCDC publications may be purchased at [www.ejcdc.org](http://www.ejcdc.org), or from any of the sponsoring organizations above.

# STANDARD GENERAL CONDITIONS OF THE CONSTRUCTION CONTRACT

## TABLE OF CONTENTS

	<b>Page</b>
Article 1 – Definitions and Terminology .....	1
1.01 Defined Terms .....	1
1.02 Terminology .....	5
Article 2 – Preliminary Matters .....	6
2.01 Delivery of Bonds and Evidence of Insurance .....	6
2.02 Copies of Documents .....	6
2.03 Before Starting Construction .....	6
2.04 Preconstruction Conference; Designation of Authorized Representatives .....	7
2.05 Initial Acceptance of Schedules .....	7
2.06 Electronic Transmittals .....	7
Article 3 – Documents: Intent, Requirements, Reuse .....	8
3.01 Intent .....	8
3.02 Reference Standards .....	8
3.03 Reporting and Resolving Discrepancies .....	8
3.04 Requirements of the Contract Documents .....	9
3.05 Reuse of Documents .....	10
Article 4 – Commencement and Progress of the Work .....	10
4.01 Commencement of Contract Times; Notice to Proceed .....	10
4.02 Starting the Work .....	10
4.03 Reference Points .....	10
4.04 Progress Schedule .....	10
4.05 Delays in Contractor’s Progress .....	11
Article 5 – Availability of Lands; Subsurface and Physical Conditions; Hazardous Environmental Conditions .....	12
5.01 Availability of Lands .....	12
5.02 Use of Site and Other Areas .....	12
5.03 Subsurface and Physical Conditions .....	13
5.04 Differing Subsurface or Physical Conditions .....	14
5.05 Underground Facilities .....	15

5.06	Hazardous Environmental Conditions at Site .....	17
Article 6 – Bonds and Insurance .....		19
6.01	Performance, Payment, and Other Bonds .....	19
6.02	Insurance—General Provisions .....	19
6.03	Contractor’s Insurance .....	20
6.04	Owner’s Liability Insurance .....	23
6.05	Property Insurance.....	23
6.06	Waiver of Rights .....	25
6.07	Receipt and Application of Property Insurance Proceeds .....	25
Article 7 – Contractor’s Responsibilities .....		26
7.01	Supervision and Superintendence .....	26
7.02	Labor; Working Hours .....	26
7.03	Services, Materials, and Equipment.....	26
7.04	“Or Equals” .....	27
7.05	Substitutes .....	28
7.06	Concerning Subcontractors, Suppliers, and Others .....	29
7.07	Patent Fees and Royalties .....	31
7.08	Permits .....	31
7.09	Taxes .....	32
7.10	Laws and Regulations.....	32
7.11	Record Documents .....	32
7.12	Safety and Protection.....	32
7.13	Safety Representative .....	33
7.14	Hazard Communication Programs .....	33
7.15	Emergencies .....	34
7.16	Shop Drawings, Samples, and Other Submittals.....	34
7.17	Contractor’s General Warranty and Guarantee.....	36
7.18	Indemnification .....	37
7.19	Delegation of Professional Design Services .....	37
Article 8 – Other Work at the Site .....		38
8.01	Other Work .....	38
8.02	Coordination .....	39
8.03	Legal Relationships.....	39



Article 9 – Owner’s Responsibilities.....	40
9.01 Communications to Contractor.....	40
9.02 Replacement of Engineer .....	40
9.03 Furnish Data .....	40
9.04 Pay When Due.....	40
9.05 Lands and Easements; Reports, Tests, and Drawings .....	40
9.06 Insurance .....	40
9.07 Change Orders.....	40
9.08 Inspections, Tests, and Approvals.....	41
9.09 Limitations on Owner’s Responsibilities .....	41
9.10 Undisclosed Hazardous Environmental Condition.....	41
9.11 Evidence of Financial Arrangements.....	41
9.12 Safety Programs .....	41
Article 10 – Engineer’s Status During Construction.....	41
10.01 Owner’s Representative.....	41
10.02 Visits to Site.....	41
10.03 Project Representative.....	42
10.04 Rejecting Defective Work.....	42
10.05 Shop Drawings, Change Orders and Payments.....	42
10.06 Determinations for Unit Price Work .....	42
10.07 Decisions on Requirements of Contract Documents and Acceptability of Work .....	42
10.08 Limitations on Engineer’s Authority and Responsibilities.....	42
10.09 Compliance with Safety Program.....	43
Article 11 – Amending the Contract Documents; Changes in the Work .....	43
11.01 Amending and Supplementing Contract Documents .....	43
11.02 Owner-Authorized Changes in the Work .....	44
11.03 Unauthorized Changes in the Work .....	44
11.04 Change of Contract Price .....	44
11.05 Change of Contract Times .....	45
11.06 Change Proposals .....	45
11.07 Execution of Change Orders.....	46
11.08 Notification to Surety.....	47
Article 12 – Claims.....	47

12.01	Claims .....	47
Article 13 –	Cost of the Work; Allowances; Unit Price Work.....	48
13.01	Cost of the Work .....	48
13.02	Allowances .....	50
13.03	Unit Price Work .....	51
Article 14 –	Tests and Inspections; Correction, Removal or Acceptance of Defective Work.....	52
14.01	Access to Work.....	52
14.02	Tests, Inspections, and Approvals.....	52
14.03	Defective Work.....	53
14.04	Acceptance of Defective Work.....	53
14.05	Uncovering Work .....	53
14.06	Owner May Stop the Work .....	54
14.07	Owner May Correct Defective Work.....	54
Article 15 –	Payments to Contractor; Set-Offs; Completion; Correction Period .....	55
15.01	Progress Payments.....	55
15.02	Contractor’s Warranty of Title .....	58
15.03	Substantial Completion.....	58
15.04	Partial Use or Occupancy .....	59
15.05	Final Inspection .....	59
15.06	Final Payment.....	59
15.07	Waiver of Claims .....	61
15.08	Correction Period .....	61
Article 16 –	Suspension of Work and Termination .....	62
16.01	Owner May Suspend Work .....	62
16.02	Owner May Terminate for Cause .....	62
16.03	Owner May Terminate For Convenience .....	63
16.04	Contractor May Stop Work or Terminate .....	63
Article 17 –	Final Resolution of Disputes .....	64
17.01	Methods and Procedures.....	64
Article 18 –	Miscellaneous .....	64
18.01	Giving Notice .....	64
18.02	Computation of Times.....	64
18.03	Cumulative Remedies .....	64

18.04	Limitation of Damages .....	65
18.05	No Waiver .....	65
18.06	Survival of Obligations .....	65
18.07	Controlling Law .....	65
18.08	Headings.....	65

## ARTICLE 1 – DEFINITIONS AND TERMINOLOGY

### 1.01 *Defined Terms*

- A. Wherever used in the Bidding Requirements or Contract Documents, a term printed with initial capital letters, including the term's singular and plural forms, will have the meaning indicated in the definitions below. In addition to terms specifically defined, terms with initial capital letters in the Contract Documents include references to identified articles and paragraphs, and the titles of other documents or forms.
1. *Addenda*—Written or graphic instruments issued prior to the opening of Bids which clarify, correct, or change the Bidding Requirements or the proposed Contract Documents.
  2. *Agreement*—The written instrument, executed by Owner and Contractor, that sets forth the Contract Price and Contract Times, identifies the parties and the Engineer, and designates the specific items that are Contract Documents.
  3. *Application for Payment*—The form acceptable to Engineer which is to be used by Contractor during the course of the Work in requesting progress or final payments and which is to be accompanied by such supporting documentation as is required by the Contract Documents.
  4. *Bid*—The offer of a Bidder submitted on the prescribed form setting forth the prices for the Work to be performed.
  5. *Bidder*—An individual or entity that submits a Bid to Owner.
  6. *Bidding Documents*—The Bidding Requirements, the proposed Contract Documents, and all Addenda.
  7. *Bidding Requirements*—The advertisement or invitation to bid, Instructions to Bidders, Bid Bond or other Bid security, if any, the Bid Form, and the Bid with any attachments.
  8. *Change Order*—A document which is signed by Contractor and Owner and authorizes an addition, deletion, or revision in the Work or an adjustment in the Contract Price or the Contract Times, or other revision to the Contract, issued on or after the Effective Date of the Contract.
  9. *Change Proposal*—A written request by Contractor, duly submitted in compliance with the procedural requirements set forth herein, seeking an adjustment in Contract Price or Contract Times, or both; contesting an initial decision by Engineer concerning the requirements of the Contract Documents or the acceptability of Work under the Contract Documents; challenging a set-off against payments due; or seeking other relief with respect to the terms of the Contract.
  10. *Claim*—(a) A demand or assertion by Owner directly to Contractor, duly submitted in compliance with the procedural requirements set forth herein: seeking an adjustment of Contract Price or Contract Times, or both; contesting an initial decision by Engineer concerning the requirements of the Contract Documents or the acceptability of Work under the Contract Documents; contesting Engineer's decision regarding a Change Proposal; seeking resolution of a contractual issue that Engineer has declined to address; or seeking other relief with respect to the terms of the Contract; or (b) a demand or assertion by Contractor directly to Owner, duly submitted in compliance with the procedural requirements set forth herein, contesting Engineer's decision regarding a Change Proposal; or seeking resolution of a contractual issue that Engineer

has declined to address. A demand for money or services by a third party is not a Claim.

11. *Constituent of Concern*—Asbestos, petroleum, radioactive materials, polychlorinated biphenyls (PCBs), hazardous waste, and any substance, product, waste, or other material of any nature whatsoever that is or becomes listed, regulated, or addressed pursuant to (a) the Comprehensive Environmental Response, Compensation and Liability Act, 42 U.S.C. §§9601 et seq. (“CERCLA”); (b) the Hazardous Materials Transportation Act, 49 U.S.C. §§5501 et seq.; (c) the Resource Conservation and Recovery Act, 42 U.S.C. §§6901 et seq. (“RCRA”); (d) the Toxic Substances Control Act, 15 U.S.C. §§2601 et seq.; (e) the Clean Water Act, 33 U.S.C. §§1251 et seq.; (f) the Clean Air Act, 42 U.S.C. §§7401 et seq.; or (g) any other federal, state, or local statute, law, rule, regulation, ordinance, resolution, code, order, or decree regulating, relating to, or imposing liability or standards of conduct concerning, any hazardous, toxic, or dangerous waste, substance, or material.
12. *Contract*—The entire and integrated written contract between the Owner and Contractor concerning the Work.
13. *Contract Documents*—Those items so designated in the Agreement, and which together comprise the Contract.
14. *Contract Price*—The money that Owner has agreed to pay Contractor for completion of the Work in accordance with the Contract Documents. .
15. *Contract Times*—The number of days or the dates by which Contractor shall: (a) achieve Milestones, if any; (b) achieve Substantial Completion; and (c) complete the Work.
16. *Contractor*—The individual or entity with which Owner has contracted for performance of the Work.
17. *Cost of the Work*—See Paragraph 13.01 for definition.
18. *Drawings*—The part of the Contract that graphically shows the scope, extent, and character of the Work to be performed by Contractor.
19. *Effective Date of the Contract*—The date, indicated in the Agreement, on which the Contract becomes effective.
20. *Engineer*—The individual or entity named as such in the Agreement.
21. *Field Order*—A written order issued by Engineer which requires minor changes in the Work but does not change the Contract Price or the Contract Times.
22. *Hazardous Environmental Condition*—The presence at the Site of Constituents of Concern in such quantities or circumstances that may present a danger to persons or property exposed thereto. The presence at the Site of materials that are necessary for the execution of the Work, or that are to be incorporated in the Work, and that are controlled and contained pursuant to industry practices, Laws and Regulations, and the requirements of the Contract, does not establish a Hazardous Environmental Condition.
23. *Laws and Regulations; Laws or Regulations*—Any and all applicable laws, statutes, rules, regulations, ordinances, codes, and orders of any and all governmental bodies, agencies, authorities, and courts having jurisdiction.

24. *Liens*—Charges, security interests, or encumbrances upon Contract-related funds, real property, or personal property.
25. *Milestone*—A principal event in the performance of the Work that the Contract requires Contractor to achieve by an intermediate completion date or by a time prior to Substantial Completion of all the Work.
26. *Notice of Award*—The written notice by Owner to a Bidder of Owner’s acceptance of the Bid.
27. *Notice to Proceed*—A written notice by Owner to Contractor fixing the date on which the Contract Times will commence to run and on which Contractor shall start to perform the Work.
28. *Owner*—The individual or entity with which Contractor has contracted regarding the Work, and which has agreed to pay Contractor for the performance of the Work, pursuant to the terms of the Contract.
29. *Progress Schedule*—A schedule, prepared and maintained by Contractor, describing the sequence and duration of the activities comprising the Contractor’s plan to accomplish the Work within the Contract Times.
30. *Project*—The total undertaking to be accomplished for Owner by engineers, contractors, and others, including planning, study, design, construction, testing, commissioning, and start-up, and of which the Work to be performed under the Contract Documents is a part.
31. *Project Manual*—The written documents prepared for, or made available for, procuring and constructing the Work, including but not limited to the Bidding Documents or other construction procurement documents, geotechnical and existing conditions information, the Agreement, bond forms, General Conditions, Supplementary Conditions, and Specifications. The contents of the Project Manual may be bound in one or more volumes.
32. *Resident Project Representative*—The authorized representative of Engineer assigned to assist Engineer at the Site. As used herein, the term Resident Project Representative or “RPR” includes any assistants or field staff of Resident Project Representative.
33. *Samples*—Physical examples of materials, equipment, or workmanship that are representative of some portion of the Work and that establish the standards by which such portion of the Work will be judged.
34. *Schedule of Submittals*—A schedule, prepared and maintained by Contractor, of required submittals and the time requirements for Engineer’s review of the submittals and the performance of related construction activities.
35. *Schedule of Values*—A schedule, prepared and maintained by Contractor, allocating portions of the Contract Price to various portions of the Work and used as the basis for reviewing Contractor’s Applications for Payment.
36. *Shop Drawings*—All drawings, diagrams, illustrations, schedules, and other data or information that are specifically prepared or assembled by or for Contractor and submitted by Contractor to illustrate some portion of the Work. Shop Drawings, whether approved or not, are not Drawings and are not Contract Documents.

37. *Site*—Lands or areas indicated in the Contract Documents as being furnished by Owner upon which the Work is to be performed, including rights-of-way and easements, and such other lands furnished by Owner which are designated for the use of Contractor.
38. *Specifications*—The part of the Contract that consists of written requirements for materials, equipment, systems, standards, and workmanship as applied to the Work, and certain administrative requirements and procedural matters applicable to the Work.
39. *Subcontractor*—An individual or entity having a direct contract with Contractor or with any other Subcontractor for the performance of a part of the Work.
40. *Substantial Completion*—The time at which the Work (or a specified part thereof) has progressed to the point where, in the opinion of Engineer, the Work (or a specified part thereof) is sufficiently complete, in accordance with the Contract Documents, so that the Work (or a specified part thereof) can be utilized for the purposes for which it is intended. The terms “substantially complete” and “substantially completed” as applied to all or part of the Work refer to Substantial Completion thereof.
41. *Successful Bidder*—The Bidder whose Bid the Owner accepts, and to which the Owner makes an award of contract, subject to stated conditions.
42. *Supplementary Conditions*—The part of the Contract that amends or supplements these General Conditions.
43. *Supplier*—A manufacturer, fabricator, supplier, distributor, materialman, or vendor having a direct contract with Contractor or with any Subcontractor to furnish materials or equipment to be incorporated in the Work by Contractor or a Subcontractor.
44. *Technical Data*—Those items expressly identified as Technical Data in the Supplementary Conditions, with respect to either (a) subsurface conditions at the Site, or physical conditions relating to existing surface or subsurface structures at the Site (except Underground Facilities) or (b) Hazardous Environmental Conditions at the Site. If no such express identifications of Technical Data have been made with respect to conditions at the Site, then the data contained in boring logs, recorded measurements of subsurface water levels, laboratory test results, and other factual, objective information regarding conditions at the Site that are set forth in any geotechnical or environmental report prepared for the Project and made available to Contractor are hereby defined as Technical Data with respect to conditions at the Site under Paragraphs 5.03, 5.04, and 5.06.
45. *Underground Facilities*—All underground pipelines, conduits, ducts, cables, wires, manholes, vaults, tanks, tunnels, or other such facilities or attachments, and any encasements containing such facilities, including but not limited to those that convey electricity, gases, steam, liquid petroleum products, telephone or other communications, fiber optic transmissions, cable television, water, wastewater, storm water, other liquids or chemicals, or traffic or other control systems.
46. *Unit Price Work*—Work to be paid for on the basis of unit prices.
47. *Work*—The entire construction or the various separately identifiable parts thereof required to be provided under the Contract Documents. Work includes and is the result of performing or providing all labor, services, and documentation necessary to produce such construction; furnishing, installing, and incorporating all materials and equipment into such construction; and may include related services such as testing, start-up, and commissioning, all as required by the Contract Documents.

48. *Work Change Directive*—A written directive to Contractor issued on or after the Effective Date of the Contract, signed by Owner and recommended by Engineer, ordering an addition, deletion, or revision in the Work.

## 1.02 Terminology

- A. The words and terms discussed in the following paragraphs are not defined but, when used in the Bidding Requirements or Contract Documents, have the indicated meaning.
- B. *Intent of Certain Terms or Adjectives:*
  1. The Contract Documents include the terms “as allowed,” “as approved,” “as ordered,” “as directed” or terms of like effect or import to authorize an exercise of professional judgment by Engineer. In addition, the adjectives “reasonable,” “suitable,” “acceptable,” “proper,” “satisfactory,” or adjectives of like effect or import are used to describe an action or determination of Engineer as to the Work. It is intended that such exercise of professional judgment, action, or determination will be solely to evaluate, in general, the Work for compliance with the information in the Contract Documents and with the design concept of the Project as a functioning whole as shown or indicated in the Contract Documents (unless there is a specific statement indicating otherwise). The use of any such term or adjective is not intended to and shall not be effective to assign to Engineer any duty or authority to supervise or direct the performance of the Work, or any duty or authority to undertake responsibility contrary to the provisions of Article 10 or any other provision of the Contract Documents.
- C. *Day:*
  1. The word “day” means a calendar day of 24 hours measured from midnight to the next midnight.
- D. *Defective:*
  1. The word “defective,” when modifying the word “Work,” refers to Work that is unsatisfactory, faulty, or deficient in that it:
    - a. does not conform to the Contract Documents; or
    - b. does not meet the requirements of any applicable inspection, reference standard, test, or approval referred to in the Contract Documents; or
    - c. has been damaged prior to Engineer’s recommendation of final payment (unless responsibility for the protection thereof has been assumed by Owner at Substantial Completion in accordance with Paragraph 15.03 or 15.04).
- E. *Furnish, Install, Perform, Provide:*
  1. The word “furnish,” when used in connection with services, materials, or equipment, shall mean to supply and deliver said services, materials, or equipment to the Site (or some other specified location) ready for use or installation and in usable or operable condition.
  2. The word “install,” when used in connection with services, materials, or equipment, shall mean to put into use or place in final position said services, materials, or equipment complete and ready for intended use.



3. The words “perform” or “provide,” when used in connection with services, materials, or equipment, shall mean to furnish and install said services, materials, or equipment complete and ready for intended use.
  4. If the Contract Documents establish an obligation of Contractor with respect to specific services, materials, or equipment, but do not expressly use any of the four words “furnish,” “install,” “perform,” or “provide,” then Contractor shall furnish and install said services, materials, or equipment complete and ready for intended use.
- F. Unless stated otherwise in the Contract Documents, words or phrases that have a well-known technical or construction industry or trade meaning are used in the Contract Documents in accordance with such recognized meaning.

## **ARTICLE 2 – PRELIMINARY MATTERS**

### **2.01 *Delivery of Bonds and Evidence of Insurance***

- A. *Bonds*: When Contractor delivers the executed counterparts of the Agreement to Owner, Contractor shall also deliver to Owner such bonds as Contractor may be required to furnish.
- B. *Evidence of Contractor’s Insurance*: When Contractor delivers the executed counterparts of the Agreement to Owner, Contractor shall also deliver to Owner, with copies to each named insured and additional insured (as identified in the Supplementary Conditions or elsewhere in the Contract), the certificates and other evidence of insurance required to be provided by Contractor in accordance with Article 6.
- C. *Evidence of Owner’s Insurance*: After receipt of the executed counterparts of the Agreement and all required bonds and insurance documentation, Owner shall promptly deliver to Contractor, with copies to each named insured and additional insured (as identified in the Supplementary Conditions or otherwise), the certificates and other evidence of insurance required to be provided by Owner under Article 6.

### **2.02 *Copies of Documents***

- A. Owner shall furnish to Contractor four printed copies of the Contract (including one fully executed counterpart of the Agreement), and one copy in electronic portable document format (PDF). Additional printed copies will be furnished upon request at the cost of reproduction.
- B. Owner shall maintain and safeguard at least one original printed record version of the Contract, including Drawings and Specifications signed and sealed by Engineer and other design professionals. Owner shall make such original printed record version of the Contract available to Contractor for review. Owner may delegate the responsibilities under this provision to Engineer.

### **2.03 *Before Starting Construction***

- A. *Preliminary Schedules*: Within 10 days after the Effective Date of the Contract (or as otherwise specifically required by the Contract Documents), Contractor shall submit to Engineer for timely review:
  1. a preliminary Progress Schedule indicating the times (numbers of days or dates) for starting and completing the various stages of the Work, including any Milestones specified in the Contract;
  2. a preliminary Schedule of Submittals; and

3. a preliminary Schedule of Values for all of the Work which includes quantities and prices of items which when added together equal the Contract Price and subdivides the Work into component parts in sufficient detail to serve as the basis for progress payments during performance of the Work. Such prices will include an appropriate amount of overhead and profit applicable to each item of Work.

#### 2.04 *Preconstruction Conference; Designation of Authorized Representatives*

- A. Before any Work at the Site is started, a conference attended by Owner, Contractor, Engineer, and others as appropriate will be held to establish a working understanding among the parties as to the Work and to discuss the schedules referred to in Paragraph 2.03.A, procedures for handling Shop Drawings, Samples, and other submittals, processing Applications for Payment, electronic or digital transmittals, and maintaining required records.
- B. At this conference Owner and Contractor each shall designate, in writing, a specific individual to act as its authorized representative with respect to the services and responsibilities under the Contract. Such individuals shall have the authority to transmit and receive information, render decisions relative to the Contract, and otherwise act on behalf of each respective party.

#### 2.05 *Initial Acceptance of Schedules*

- A. At least 10 days before submission of the first Application for Payment a conference, attended by Contractor, Engineer, and others as appropriate, will be held to review for acceptability to Engineer as provided below the schedules submitted in accordance with Paragraph 2.03.A. Contractor shall have an additional 10 days to make corrections and adjustments and to complete and resubmit the schedules. No progress payment shall be made to Contractor until acceptable schedules are submitted to Engineer.
  1. The Progress Schedule will be acceptable to Engineer if it provides an orderly progression of the Work to completion within the Contract Times. Such acceptance will not impose on Engineer responsibility for the Progress Schedule, for sequencing, scheduling, or progress of the Work, nor interfere with or relieve Contractor from Contractor's full responsibility therefor.
  2. Contractor's Schedule of Submittals will be acceptable to Engineer if it provides a workable arrangement for reviewing and processing the required submittals.
  3. Contractor's Schedule of Values will be acceptable to Engineer as to form and substance if it provides a reasonable allocation of the Contract Price to the component parts of the Work.

#### 2.06 *Electronic Transmittals*

- A. Except as otherwise stated elsewhere in the Contract, the Owner, Engineer, and Contractor may transmit, and shall accept, Project-related correspondence, text, data, documents, drawings, information, and graphics, including but not limited to Shop Drawings and other submittals, in electronic media or digital format, either directly, or through access to a secure Project website.
- B. If the Contract does not establish protocols for electronic or digital transmittals, then Owner, Engineer, and Contractor shall jointly develop such protocols.
- C. When transmitting items in electronic media or digital format, the transmitting party makes no representations as to long term compatibility, usability, or readability of the items resulting from the recipient's use of software application packages, operating systems, or

computer hardware differing from those used in the drafting or transmittal of the items, or from those established in applicable transmittal protocols.

### **ARTICLE 3 – DOCUMENTS: INTENT, REQUIREMENTS, REUSE**

#### **3.01 *Intent***

- A. The Contract Documents are complementary; what is required by one is as binding as if required by all.
- B. It is the intent of the Contract Documents to describe a functionally complete project (or part thereof) to be constructed in accordance with the Contract Documents.
- C. Unless otherwise stated in the Contract Documents, if there is a discrepancy between the electronic or digital versions of the Contract Documents (including any printed copies derived from such electronic or digital versions) and the printed record version, the printed record version shall govern.
- D. The Contract supersedes prior negotiations, representations, and agreements, whether written or oral.
- E. Engineer will issue clarifications and interpretations of the Contract Documents as provided herein.

#### **3.02 *Reference Standards***

- A. Standards Specifications, Codes, Laws and Regulations
  - 1. Reference in the Contract Documents to standard specifications, manuals, reference standards, or codes of any technical society, organization, or association, or to Laws or Regulations, whether such reference be specific or by implication, shall mean the standard specification, manual, reference standard, code, or Laws or Regulations in effect at the time of opening of Bids (or on the Effective Date of the Contract if there were no Bids), except as may be otherwise specifically stated in the Contract Documents.
  - 2. No provision of any such standard specification, manual, reference standard, or code, or any instruction of a Supplier, shall be effective to change the duties or responsibilities of Owner, Contractor, or Engineer, or any of their subcontractors, consultants, agents, or employees, from those set forth in the part of the Contract Documents prepared by or for Engineer. No such provision or instruction shall be effective to assign to Owner, Engineer, or any of their officers, directors, members, partners, employees, agents, consultants, or subcontractors, any duty or authority to supervise or direct the performance of the Work or any duty or authority to undertake responsibility inconsistent with the provisions of the part of the Contract Documents prepared by or for Engineer.

#### **3.03 *Reporting and Resolving Discrepancies***

- A. *Reporting Discrepancies:*
  - 1. *Contractor's Verification of Figures and Field Measurements:* Before undertaking each part of the Work, Contractor shall carefully study the Contract Documents, and check and verify pertinent figures and dimensions therein, particularly with respect to applicable field measurements. Contractor shall promptly report in writing to Engineer any conflict, error, ambiguity, or discrepancy that Contractor discovers, or has actual knowledge of, and shall not proceed with any Work affected thereby until the conflict,

error, ambiguity, or discrepancy is resolved, by a clarification or interpretation by Engineer, or by an amendment or supplement to the Contract Documents issued pursuant to Paragraph 11.01.

2. *Contractor's Review of Contract Documents:* If, before or during the performance of the Work, Contractor discovers any conflict, error, ambiguity, or discrepancy within the Contract Documents, or between the Contract Documents and (a) any applicable Law or Regulation, (b) actual field conditions, (c) any standard specification, manual, reference standard, or code, or (d) any instruction of any Supplier, then Contractor shall promptly report it to Engineer in writing. Contractor shall not proceed with the Work affected thereby (except in an emergency as required by Paragraph 7.15) until the conflict, error, ambiguity, or discrepancy is resolved, by a clarification or interpretation by Engineer, or by an amendment or supplement to the Contract Documents issued pursuant to Paragraph 11.01.
3. Contractor shall not be liable to Owner or Engineer for failure to report any conflict, error, ambiguity, or discrepancy in the Contract Documents unless Contractor had actual knowledge thereof.

B. *Resolving Discrepancies:*

1. Except as may be otherwise specifically stated in the Contract Documents, the provisions of the part of the Contract Documents prepared by or for Engineer shall take precedence in resolving any conflict, error, ambiguity, or discrepancy between such provisions of the Contract Documents and:
  - a. the provisions of any standard specification, manual, reference standard, or code, or the instruction of any Supplier (whether or not specifically incorporated by reference as a Contract Document); or
  - b. the provisions of any Laws or Regulations applicable to the performance of the Work (unless such an interpretation of the provisions of the Contract Documents would result in violation of such Law or Regulation).

3.04 *Requirements of the Contract Documents*

- A. During the performance of the Work and until final payment, Contractor and Owner shall submit to the Engineer all matters in question concerning the requirements of the Contract Documents (sometimes referred to as requests for information or interpretation—RFIs), or relating to the acceptability of the Work under the Contract Documents, as soon as possible after such matters arise. Engineer will be the initial interpreter of the requirements of the Contract Documents, and judge of the acceptability of the Work thereunder.
- B. Engineer will, with reasonable promptness, render a written clarification, interpretation, or decision on the issue submitted, or initiate an amendment or supplement to the Contract Documents. Engineer's written clarification, interpretation, or decision will be final and binding on Contractor, unless it appeals by submitting a Change Proposal, and on Owner, unless it appeals by filing a Claim.
- C. If a submitted matter in question concerns terms and conditions of the Contract Documents that do not involve (1) the performance or acceptability of the Work under the Contract Documents, (2) the design (as set forth in the Drawings, Specifications, or otherwise), or (3) other engineering or technical matters, then Engineer will promptly give written notice to Owner and Contractor that Engineer is unable to provide a decision or interpretation. If Owner and Contractor are unable to agree on resolution of such a matter in question, either party may pursue resolution as provided in Article 12.

### 3.05 *Reuse of Documents*

- A. Contractor and its Subcontractors and Suppliers shall not:
  - 1. have or acquire any title to or ownership rights in any of the Drawings, Specifications, or other documents (or copies of any thereof) prepared by or bearing the seal of Engineer or its consultants, including electronic media editions, or reuse any such Drawings, Specifications, other documents, or copies thereof on extensions of the Project or any other project without written consent of Owner and Engineer and specific written verification or adaptation by Engineer; or
  - 2. have or acquire any title or ownership rights in any other Contract Documents, reuse any such Contract Documents for any purpose without Owner's express written consent, or violate any copyrights pertaining to such Contract Documents.
- B. The prohibitions of this Paragraph 3.05 will survive final payment, or termination of the Contract. Nothing herein shall preclude Contractor from retaining copies of the Contract Documents for record purposes.

## **ARTICLE 4 – COMMENCEMENT AND PROGRESS OF THE WORK**

### 4.01 *Commencement of Contract Times; Notice to Proceed*

- A. The Contract Times will commence to run on the thirtieth day after the Effective Date of the Contract or, if a Notice to Proceed is given, on the day indicated in the Notice to Proceed. A Notice to Proceed may be given at any time within 30 days after the Effective Date of the Contract. In no event will the Contract Times commence to run later than the sixtieth day after the day of Bid opening or the thirtieth day after the Effective Date of the Contract, whichever date is earlier.

### 4.02 *Starting the Work*

- A. Contractor shall start to perform the Work on the date when the Contract Times commence to run. No Work shall be done at the Site prior to such date.

### 4.03 *Reference Points*

- A. Owner shall provide engineering surveys to establish reference points for construction which in Engineer's judgment are necessary to enable Contractor to proceed with the Work. Contractor shall be responsible for laying out the Work, shall protect and preserve the established reference points and property monuments, and shall make no changes or relocations without the prior written approval of Owner. Contractor shall report to Engineer whenever any reference point or property monument is lost or destroyed or requires relocation because of necessary changes in grades or locations, and shall be responsible for the accurate replacement or relocation of such reference points or property monuments by professionally qualified personnel.

### 4.04 *Progress Schedule*

- A. Contractor shall adhere to the Progress Schedule established in accordance with Paragraph 2.05 as it may be adjusted from time to time as provided below.
  - 1. Contractor shall submit to Engineer for acceptance (to the extent indicated in Paragraph 2.05) proposed adjustments in the Progress Schedule that will not result in changing the Contract Times.

2. Proposed adjustments in the Progress Schedule that will change the Contract Times shall be submitted in accordance with the requirements of Article 11.
- B. Contractor shall carry on the Work and adhere to the Progress Schedule during all disputes or disagreements with Owner. No Work shall be delayed or postponed pending resolution of any disputes or disagreements, or during any appeal process, except as permitted by Paragraph 16.04, or as Owner and Contractor may otherwise agree in writing.

#### 4.05 *Delays in Contractor's Progress*

- A. If Owner, Engineer, or anyone for whom Owner is responsible, delays, disrupts, or interferes with the performance or progress of the Work, then Contractor shall be entitled to an equitable adjustment in the Contract Times and Contract Price. Contractor's entitlement to an adjustment of the Contract Times is conditioned on such adjustment being essential to Contractor's ability to complete the Work within the Contract Times.
- B. Contractor shall not be entitled to an adjustment in Contract Price or Contract Times for delay, disruption, or interference caused by or within the control of Contractor. Delay, disruption, and interference attributable to and within the control of a Subcontractor or Supplier shall be deemed to be within the control of Contractor.
- C. If Contractor's performance or progress is delayed, disrupted, or interfered with by unanticipated causes not the fault of and beyond the control of Owner, Contractor, and those for which they are responsible, then Contractor shall be entitled to an equitable adjustment in Contract Times. Contractor's entitlement to an adjustment of the Contract Times is conditioned on such adjustment being essential to Contractor's ability to complete the Work within the Contract Times. Such an adjustment shall be Contractor's sole and exclusive remedy for the delays, disruption, and interference described in this paragraph. Causes of delay, disruption, or interference that may give rise to an adjustment in Contract Times under this paragraph include but are not limited to the following:
1. severe and unavoidable natural catastrophes such as fires, floods, epidemics, and earthquakes;
  2. abnormal weather conditions;
  3. acts or failures to act of utility owners (other than those performing other work at or adjacent to the Site by arrangement with the Owner, as contemplated in Article 8); and
  4. acts of war or terrorism.
- D. Delays, disruption, and interference to the performance or progress of the Work resulting from the existence of a differing subsurface or physical condition, an Underground Facility that was not shown or indicated by the Contract Documents, or not shown or indicated with reasonable accuracy, and those resulting from Hazardous Environmental Conditions, are governed by Article 5.
- E. Paragraph 8.03 governs delays, disruption, and interference to the performance or progress of the Work resulting from the performance of certain other work at or adjacent to the Site.
- F. Contractor shall not be entitled to an adjustment in Contract Price or Contract Times for any delay, disruption, or interference if such delay is concurrent with a delay, disruption, or interference caused by or within the control of Contractor.

- G. Contractor must submit any Change Proposal seeking an adjustment in Contract Price or Contract Times under this paragraph within 30 days of the commencement of the delaying, disrupting, or interfering event.

**ARTICLE 5 – AVAILABILITY OF LANDS; SUBSURFACE AND PHYSICAL CONDITIONS; HAZARDOUS ENVIRONMENTAL CONDITIONS**

5.01 *Availability of Lands*

- A. Owner shall furnish the Site. Owner shall notify Contractor of any encumbrances or restrictions not of general application but specifically related to use of the Site with which Contractor must comply in performing the Work.
- B. Upon reasonable written request, Owner shall furnish Contractor with a current statement of record legal title and legal description of the lands upon which permanent improvements are to be made and Owner's interest therein as necessary for giving notice of or filing a mechanic's or construction lien against such lands in accordance with applicable Laws and Regulations.
- C. Contractor shall provide for all additional lands and access thereto that may be required for temporary construction facilities or storage of materials and equipment.

5.02 *Use of Site and Other Areas*

- A. *Limitation on Use of Site and Other Areas:*
  - 1. Contractor shall confine construction equipment, temporary construction facilities, the storage of materials and equipment, and the operations of workers to the Site, adjacent areas that Contractor has arranged to use through construction easements or otherwise, and other adjacent areas permitted by Laws and Regulations, and shall not unreasonably encumber the Site and such other adjacent areas with construction equipment or other materials or equipment. Contractor shall assume full responsibility for (a) damage to the Site; (b) damage to any such other adjacent areas used for Contractor's operations; (c) damage to any other adjacent land or areas; and (d) for injuries and losses sustained by the owners or occupants of any such land or areas; provided that such damage or injuries result from the performance of the Work or from other actions or conduct of the Contractor or those for which Contractor is responsible.
  - 2. If a damage or injury claim is made by the owner or occupant of any such land or area because of the performance of the Work, or because of other actions or conduct of the Contractor or those for which Contractor is responsible, Contractor shall (a) take immediate corrective or remedial action as required by Paragraph 7.12, or otherwise; (b) promptly attempt to settle the claim as to all parties through negotiations with such owner or occupant, or otherwise resolve the claim by arbitration or other dispute resolution proceeding, or at law; and (c) to the fullest extent permitted by Laws and Regulations, indemnify and hold harmless Owner and Engineer, and the officers, directors, members, partners, employees, agents, consultants and subcontractors of each and any of them from and against any such claim, and against all costs, losses, and damages (including but not limited to all fees and charges of engineers, architects, attorneys, and other professionals and all court or arbitration or other dispute resolution costs) arising out of or relating to any claim or action, legal or equitable, brought by any such owner or occupant against Owner, Engineer, or any other party indemnified hereunder to the extent caused directly or indirectly, in whole or in part

by, or based upon, Contractor's performance of the Work, or because of other actions or conduct of the Contractor or those for which Contractor is responsible.

- B. *Removal of Debris During Performance of the Work:* During the progress of the Work the Contractor shall keep the Site and other adjacent areas free from accumulations of waste materials, rubbish, and other debris. Removal and disposal of such waste materials, rubbish, and other debris shall conform to applicable Laws and Regulations.
- C. *Cleaning:* Prior to Substantial Completion of the Work Contractor shall clean the Site and the Work and make it ready for utilization by Owner. At the completion of the Work Contractor shall remove from the Site and adjacent areas all tools, appliances, construction equipment and machinery, and surplus materials and shall restore to original condition all property not designated for alteration by the Contract Documents.
- D. *Loading of Structures:* Contractor shall not load nor permit any part of any structure to be loaded in any manner that will endanger the structure, nor shall Contractor subject any part of the Work or adjacent structures or land to stresses or pressures that will endanger them.

### 5.03 *Subsurface and Physical Conditions*

- A. *Reports and Drawings:* The Supplementary Conditions identify:
  - 1. those reports known to Owner of explorations and tests of subsurface conditions at or adjacent to the Site;
  - 2. those drawings known to Owner of physical conditions relating to existing surface or subsurface structures at the Site (except Underground Facilities); and
  - 3. Technical Data contained in such reports and drawings.
- B. *Reliance by Contractor on Technical Data Authorized:* Contractor may rely upon the accuracy of the Technical Data expressly identified in the Supplementary Conditions with respect to such reports and drawings, but such reports and drawings are not Contract Documents. If no such express identification has been made, then Contractor may rely upon the accuracy of the Technical Data (as defined in Article 1) contained in any geotechnical or environmental report prepared for the Project and made available to Contractor. Except for such reliance on Technical Data, Contractor may not rely upon or make any claim against Owner or Engineer, or any of their officers, directors, members, partners, employees, agents, consultants, or subcontractors, with respect to:
  - 1. the completeness of such reports and drawings for Contractor's purposes, including, but not limited to, any aspects of the means, methods, techniques, sequences, and procedures of construction to be employed by Contractor, and safety precautions and programs incident thereto; or
  - 2. other data, interpretations, opinions, and information contained in such reports or shown or indicated in such drawings; or
  - 3. any Contractor interpretation of or conclusion drawn from any Technical Data or any such other data, interpretations, opinions, or information.



#### 5.04 *Differing Subsurface or Physical Conditions*

- A. *Notice by Contractor:* If Contractor believes that any subsurface or physical condition that is uncovered or revealed at the Site either:
1. is of such a nature as to establish that any Technical Data on which Contractor is entitled to rely as provided in Paragraph 5.03 is materially inaccurate; or
  2. is of such a nature as to require a change in the Drawings or Specifications; or
  3. differs materially from that shown or indicated in the Contract Documents; or
  4. is of an unusual nature, and differs materially from conditions ordinarily encountered and generally recognized as inherent in work of the character provided for in the Contract Documents;

then Contractor shall, promptly after becoming aware thereof and before further disturbing the subsurface or physical conditions or performing any Work in connection therewith (except in an emergency as required by Paragraph 7.15), notify Owner and Engineer in writing about such condition. Contractor shall not further disturb such condition or perform any Work in connection therewith (except with respect to an emergency) until receipt of a written statement permitting Contractor to do so.

- B. *Engineer's Review:* After receipt of written notice as required by the preceding paragraph, Engineer will promptly review the subsurface or physical condition in question; determine the necessity of Owner's obtaining additional exploration or tests with respect to the condition; conclude whether the condition falls within any one or more of the differing site condition categories in Paragraph 5.04.A above; obtain any pertinent cost or schedule information from Contractor; prepare recommendations to Owner regarding the Contractor's resumption of Work in connection with the subsurface or physical condition in question and the need for any change in the Drawings or Specifications; and advise Owner in writing of Engineer's findings, conclusions, and recommendations.
- C. *Owner's Statement to Contractor Regarding Site Condition:* After receipt of Engineer's written findings, conclusions, and recommendations, Owner shall issue a written statement to Contractor (with a copy to Engineer) regarding the subsurface or physical condition in question, addressing the resumption of Work in connection with such condition, indicating whether any change in the Drawings or Specifications will be made, and adopting or rejecting Engineer's written findings, conclusions, and recommendations, in whole or in part.
- D. *Possible Price and Times Adjustments:*
1. Contractor shall be entitled to an equitable adjustment in Contract Price or Contract Times, or both, to the extent that the existence of a differing subsurface or physical condition, or any related delay, disruption, or interference, causes an increase or decrease in Contractor's cost of, or time required for, performance of the Work; subject, however, to the following:
    - a. such condition must fall within any one or more of the categories described in Paragraph 5.04.A;
    - b. with respect to Work that is paid for on a unit price basis, any adjustment in Contract Price will be subject to the provisions of Paragraph 13.03; and,

- c. Contractor's entitlement to an adjustment of the Contract Times is conditioned on such adjustment being essential to Contractor's ability to complete the Work within the Contract Times.
2. Contractor shall not be entitled to any adjustment in the Contract Price or Contract Times with respect to a subsurface or physical condition if:
  - a. Contractor knew of the existence of such condition at the time Contractor made a commitment to Owner with respect to Contract Price and Contract Times by the submission of a Bid or becoming bound under a negotiated contract, or otherwise; or
  - b. the existence of such condition reasonably could have been discovered or revealed as a result of any examination, investigation, exploration, test, or study of the Site and contiguous areas expressly required by the Bidding Requirements or Contract Documents to be conducted by or for Contractor prior to Contractor's making such commitment; or
  - c. Contractor failed to give the written notice as required by Paragraph 5.04.A.
3. If Owner and Contractor agree regarding Contractor's entitlement to and the amount or extent of any adjustment in the Contract Price or Contract Times, or both, then any such adjustment shall be set forth in a Change Order.
4. Contractor may submit a Change Proposal regarding its entitlement to or the amount or extent of any adjustment in the Contract Price or Contract Times, or both, no later than 30 days after Owner's issuance of the Owner's written statement to Contractor regarding the subsurface or physical condition in question.

#### 5.05 *Underground Facilities*

- A. *Contractor's Responsibilities:* The information and data shown or indicated in the Contract Documents with respect to existing Underground Facilities at or adjacent to the Site is based on information and data furnished to Owner or Engineer by the owners of such Underground Facilities, including Owner, or by others. Unless it is otherwise expressly provided in the Supplementary Conditions:
  1. Owner and Engineer do not warrant or guarantee the accuracy or completeness of any such information or data provided by others; and
  2. the cost of all of the following will be included in the Contract Price, and Contractor shall have full responsibility for:
    - a. reviewing and checking all information and data regarding existing Underground Facilities at the Site;
    - b. locating all Underground Facilities shown or indicated in the Contract Documents as being at the Site;
    - c. coordination of the Work with the owners (including Owner) of such Underground Facilities, during construction; and
    - d. the safety and protection of all existing Underground Facilities at the Site, and repairing any damage thereto resulting from the Work.
- B. *Notice by Contractor:* If Contractor believes that an Underground Facility that is uncovered or revealed at the Site was not shown or indicated in the Contract Documents, or was not shown or indicated with reasonable accuracy, then Contractor shall, promptly after

becoming aware thereof and before further disturbing conditions affected thereby or performing any Work in connection therewith (except in an emergency as required by Paragraph 7.15), identify the owner of such Underground Facility and give written notice to that owner and to Owner and Engineer.

- C. *Engineer's Review:* Engineer will promptly review the Underground Facility and conclude whether such Underground Facility was not shown or indicated in the Contract Documents, or was not shown or indicated with reasonable accuracy; obtain any pertinent cost or schedule information from Contractor; prepare recommendations to Owner regarding the Contractor's resumption of Work in connection with the Underground Facility in question; determine the extent, if any, to which a change is required in the Drawings or Specifications to reflect and document the consequences of the existence or location of the Underground Facility; and advise Owner in writing of Engineer's findings, conclusions, and recommendations. During such time, Contractor shall be responsible for the safety and protection of such Underground Facility.
- D. *Owner's Statement to Contractor Regarding Underground Facility:* After receipt of Engineer's written findings, conclusions, and recommendations, Owner shall issue a written statement to Contractor (with a copy to Engineer) regarding the Underground Facility in question, addressing the resumption of Work in connection with such Underground Facility, indicating whether any change in the Drawings or Specifications will be made, and adopting or rejecting Engineer's written findings, conclusions, and recommendations in whole or in part.
- E. *Possible Price and Times Adjustments:*
  - 1. Contractor shall be entitled to an equitable adjustment in the Contract Price or Contract Times, or both, to the extent that any existing Underground Facility at the Site that was not shown or indicated in the Contract Documents, or was not shown or indicated with reasonable accuracy, or any related delay, disruption, or interference, causes an increase or decrease in Contractor's cost of, or time required for, performance of the Work; subject, however, to the following:
    - a. Contractor did not know of and could not reasonably have been expected to be aware of or to have anticipated the existence or actual location of the Underground Facility in question;
    - b. With respect to Work that is paid for on a unit price basis, any adjustment in Contract Price will be subject to the provisions of Paragraph 13.03;
    - c. Contractor's entitlement to an adjustment of the Contract Times is conditioned on such adjustment being essential to Contractor's ability to complete the Work within the Contract Times; and
    - d. Contractor gave the notice required in Paragraph 5.05.B.
  - 2. If Owner and Contractor agree regarding Contractor's entitlement to and the amount or extent of any adjustment in the Contract Price or Contract Times, or both, then any such adjustment shall be set forth in a Change Order.
  - 3. Contractor may submit a Change Proposal regarding its entitlement to or the amount or extent of any adjustment in the Contract Price or Contract Times, or both, no later than 30 days after Owner's issuance of the Owner's written statement to Contractor regarding the Underground Facility in question.

5.06 *Hazardous Environmental Conditions at Site*

- A. *Reports and Drawings*: The Supplementary Conditions identify:
1. those reports and drawings known to Owner relating to Hazardous Environmental Conditions that have been identified at or adjacent to the Site; and
  2. Technical Data contained in such reports and drawings.
- B. *Reliance by Contractor on Technical Data Authorized*: Contractor may rely upon the accuracy of the Technical Data expressly identified in the Supplementary Conditions with respect to such reports and drawings, but such reports and drawings are not Contract Documents. If no such express identification has been made, then Contractor may rely on the accuracy of the Technical Data (as defined in Article 1) contained in any geotechnical or environmental report prepared for the Project and made available to Contractor. Except for such reliance on Technical Data, Contractor may not rely upon or make any claim against Owner or Engineer, or any of their officers, directors, members, partners, employees, agents, consultants, or subcontractors with respect to:
1. the completeness of such reports and drawings for Contractor's purposes, including, but not limited to, any aspects of the means, methods, techniques, sequences and procedures of construction to be employed by Contractor and safety precautions and programs incident thereto; or
  2. other data, interpretations, opinions and information contained in such reports or shown or indicated in such drawings; or
  3. any Contractor interpretation of or conclusion drawn from any Technical Data or any such other data, interpretations, opinions or information.
- C. Contractor shall not be responsible for removing or remediating any Hazardous Environmental Condition encountered, uncovered, or revealed at the Site unless such removal or remediation is expressly identified in the Contract Documents to be within the scope of the Work.
- D. Contractor shall be responsible for controlling, containing, and duly removing all Constituents of Concern brought to the Site by Contractor, Subcontractors, Suppliers, or anyone else for whom Contractor is responsible, and for any associated costs; and for the costs of removing and remediating any Hazardous Environmental Condition created by the presence of any such Constituents of Concern.
- E. If Contractor encounters, uncovers, or reveals a Hazardous Environmental Condition whose removal or remediation is not expressly identified in the Contract Documents as being within the scope of the Work, or if Contractor or anyone for whom Contractor is responsible creates a Hazardous Environmental Condition, then Contractor shall immediately: (1) secure or otherwise isolate such condition; (2) stop all Work in connection with such condition and in any area affected thereby (except in an emergency as required by Paragraph 7.15); and (3) notify Owner and Engineer (and promptly thereafter confirm such notice in writing). Owner shall promptly consult with Engineer concerning the necessity for Owner to retain a qualified expert to evaluate such condition or take corrective action, if any. Promptly after consulting with Engineer, Owner shall take such actions as are necessary to permit Owner to timely obtain required permits and provide Contractor the written notice required by Paragraph 5.06.F. If Contractor or anyone for whom Contractor is responsible created the Hazardous Environmental Condition in question, then Owner may remove and remediate the Hazardous Environmental Condition, and impose a set-off against payments to account for the associated costs.

- F. Contractor shall not resume Work in connection with such Hazardous Environmental Condition or in any affected area until after Owner has obtained any required permits related thereto, and delivered written notice to Contractor either (1) specifying that such condition and any affected area is or has been rendered safe for the resumption of Work, or (2) specifying any special conditions under which such Work may be resumed safely.
- G. If Owner and Contractor cannot agree as to entitlement to or on the amount or extent, if any, of any adjustment in Contract Price or Contract Times, or both, as a result of such Work stoppage or such special conditions under which Work is agreed to be resumed by Contractor, then within 30 days of Owner's written notice regarding the resumption of Work, Contractor may submit a Change Proposal, or Owner may impose a set-off.
- H. If after receipt of such written notice Contractor does not agree to resume such Work based on a reasonable belief it is unsafe, or does not agree to resume such Work under such special conditions, then Owner may order the portion of the Work that is in the area affected by such condition to be deleted from the Work, following the contractual change procedures in Article 11. Owner may have such deleted portion of the Work performed by Owner's own forces or others in accordance with Article 8.
- I. To the fullest extent permitted by Laws and Regulations, Owner shall indemnify and hold harmless Contractor, Subcontractors, and Engineer, and the officers, directors, members, partners, employees, agents, consultants, and subcontractors of each and any of them from and against all claims, costs, losses, and damages (including but not limited to all fees and charges of engineers, architects, attorneys, and other professionals and all court or arbitration or other dispute resolution costs) arising out of or relating to a Hazardous Environmental Condition, provided that such Hazardous Environmental Condition (1) was not shown or indicated in the Drawings, Specifications, or other Contract Documents, identified as Technical Data entitled to limited reliance pursuant to Paragraph 5.06.B, or identified in the Contract Documents to be included within the scope of the Work, and (2) was not created by Contractor or by anyone for whom Contractor is responsible. Nothing in this Paragraph 5.06.H shall obligate Owner to indemnify any individual or entity from and against the consequences of that individual's or entity's own negligence.
- J. To the fullest extent permitted by Laws and Regulations, Contractor shall indemnify and hold harmless Owner and Engineer, and the officers, directors, members, partners, employees, agents, consultants, and subcontractors of each and any of them from and against all claims, costs, losses, and damages (including but not limited to all fees and charges of engineers, architects, attorneys, and other professionals and all court or arbitration or other dispute resolution costs) arising out of or relating to the failure to control, contain, or remove a Constituent of Concern brought to the Site by Contractor or by anyone for whom Contractor is responsible, or to a Hazardous Environmental Condition created by Contractor or by anyone for whom Contractor is responsible. Nothing in this Paragraph 5.06.J shall obligate Contractor to indemnify any individual or entity from and against the consequences of that individual's or entity's own negligence.
- K. The provisions of Paragraphs 5.03, 5.04, and 5.05 do not apply to the presence of Constituents of Concern or to a Hazardous Environmental Condition uncovered or revealed at the Site.

## ARTICLE 6 – BONDS AND INSURANCE

### 6.01 *Performance, Payment, and Other Bonds*

- A. Contractor shall furnish a performance bond and a payment bond, each in an amount at least equal to the Contract Price, as security for the faithful performance and payment of all of Contractor's obligations under the Contract. These bonds shall remain in effect until one year after the date when final payment becomes due or until completion of the correction period specified in Paragraph 15.08, whichever is later, except as provided otherwise by Laws or Regulations, the Supplementary Conditions, or other specific provisions of the Contract. Contractor shall also furnish such other bonds as are required by the Supplementary Conditions or other specific provisions of the Contract.
- B. All bonds shall be in the form prescribed by the Contract except as provided otherwise by Laws or Regulations, and shall be executed by such sureties as are named in "Companies Holding Certificates of Authority as Acceptable Sureties on Federal Bonds and as Acceptable Reinsuring Companies" as published in Circular 570 (as amended and supplemented) by the Financial Management Service, Surety Bond Branch, U.S. Department of the Treasury. A bond signed by an agent or attorney-in-fact must be accompanied by a certified copy of that individual's authority to bind the surety. The evidence of authority shall show that it is effective on the date the agent or attorney-in-fact signed the accompanying bond.
- C. Contractor shall obtain the required bonds from surety companies that are duly licensed or authorized in the jurisdiction in which the Project is located to issue bonds in the required amounts.
- D. If the surety on a bond furnished by Contractor is declared bankrupt or becomes insolvent, or its right to do business is terminated in any state or jurisdiction where any part of the Project is located, or the surety ceases to meet the requirements above, then Contractor shall promptly notify Owner and Engineer and shall, within 20 days after the event giving rise to such notification, provide another bond and surety, both of which shall comply with the bond and surety requirements above.
- E. If Contractor has failed to obtain a required bond, Owner may exclude the Contractor from the Site and exercise Owner's termination rights under Article 16.
- F. Upon request, Owner shall provide a copy of the payment bond to any Subcontractor, Supplier, or other person or entity claiming to have furnished labor or materials used in the performance of the Work.

### 6.02 *Insurance—General Provisions*

- A. Owner and Contractor shall obtain and maintain insurance as required in this Article and in the Supplementary Conditions.
- B. All insurance required by the Contract to be purchased and maintained by Owner or Contractor shall be obtained from insurance companies that are duly licensed or authorized, in the state or jurisdiction in which the Project is located, to issue insurance policies for the required limits and coverages. Unless a different standard is indicated in the Supplementary Conditions, all companies that provide insurance policies required under this Contract shall have an A.M. Best rating of A-VII or better.
- C. Contractor shall deliver to Owner, with copies to each named insured and additional insured (as identified in this Article, in the Supplementary Conditions, or elsewhere in the Contract), certificates of insurance establishing that Contractor has obtained and is

maintaining the policies, coverages, and endorsements required by the Contract. Upon request by Owner or any other insured, Contractor shall also furnish other evidence of such required insurance, including but not limited to copies of policies and endorsements, and documentation of applicable self-insured retentions and deductibles. Contractor may block out (redact) any confidential premium or pricing information contained in any policy or endorsement furnished under this provision.

- D. Owner shall deliver to Contractor, with copies to each named insured and additional insured (as identified in this Article, the Supplementary Conditions, or elsewhere in the Contract), certificates of insurance establishing that Owner has obtained and is maintaining the policies, coverages, and endorsements required of Owner by the Contract (if any). Upon request by Contractor or any other insured, Owner shall also provide other evidence of such required insurance (if any), including but not limited to copies of policies and endorsements, and documentation of applicable self-insured retentions and deductibles. Owner may block out (redact) any confidential premium or pricing information contained in any policy or endorsement furnished under this provision.
- E. Failure of Owner or Contractor to demand such certificates or other evidence of the other party's full compliance with these insurance requirements, or failure of Owner or Contractor to identify a deficiency in compliance from the evidence provided, shall not be construed as a waiver of the other party's obligation to obtain and maintain such insurance.
- F. If either party does not purchase or maintain all of the insurance required of such party by the Contract, such party shall notify the other party in writing of such failure to purchase prior to the start of the Work, or of such failure to maintain prior to any change in the required coverage.
- G. If Contractor has failed to obtain and maintain required insurance, Owner may exclude the Contractor from the Site, impose an appropriate set-off against payment, and exercise Owner's termination rights under Article 16.
- H. Without prejudice to any other right or remedy, if a party has failed to obtain required insurance, the other party may elect to obtain equivalent insurance to protect such other party's interests at the expense of the party who was required to provide such coverage, and the Contract Price shall be adjusted accordingly.
- I. Owner does not represent that insurance coverage and limits established in this Contract necessarily will be adequate to protect Contractor or Contractor's interests.
- J. The insurance and insurance limits required herein shall not be deemed as a limitation on Contractor's liability under the indemnities granted to Owner and other individuals and entities in the Contract.

### 6.03 *Contractor's Insurance*

- A. *Workers' Compensation:* Contractor shall purchase and maintain workers' compensation and employer's liability insurance for:
  - 1. claims under workers' compensation, disability benefits, and other similar employee benefit acts.
  - 2. United States Longshoreman and Harbor Workers' Compensation Act and Jones Act coverage (if applicable).
  - 3. claims for damages because of bodily injury, occupational sickness or disease, or death of Contractor's employees (by stop-gap endorsement in monopolist worker's compensation states).

4. Foreign voluntary worker compensation (if applicable).
- B. *Commercial General Liability—Claims Covered:* Contractor shall purchase and maintain commercial general liability insurance, covering all operations by or on behalf of Contractor, on an occurrence basis, against:
1. claims for damages because of bodily injury, sickness or disease, or death of any person other than Contractor's employees.
  2. claims for damages insured by reasonably available personal injury liability coverage.
  3. claims for damages, other than to the Work itself, because of injury to or destruction of tangible property wherever located, including loss of use resulting therefrom.
- C. *Commercial General Liability—Form and Content:* Contractor's commercial liability policy shall be written on a 1996 (or later) ISO commercial general liability form (occurrence form) and include the following coverages and endorsements:
1. Products and completed operations coverage:
    - a. Such insurance shall be maintained for three years after final payment.
    - b. Contractor shall furnish Owner and each other additional insured (as identified in the Supplementary Conditions or elsewhere in the Contract) evidence of continuation of such insurance at final payment and three years thereafter.
  2. Blanket contractual liability coverage, to the extent permitted by law, including but not limited to coverage of Contractor's contractual indemnity obligations in Paragraph 7.18.
  3. Broad form property damage coverage.
  4. Severability of interest.
  5. Underground, explosion, and collapse coverage.
  6. Personal injury coverage.
  7. Additional insured endorsements that include both ongoing operations and products and completed operations coverage through ISO Endorsements CG 20 10 10 01 and CG 20 37 10 01 (together); or CG 20 10 07 04 and CG 20 37 07 04 (together); or their equivalent.
  8. For design professional additional insureds, ISO Endorsement CG 20 32 07 04, "Additional Insured—Engineers, Architects or Surveyors Not Engaged by the Named Insured" or its equivalent.
- D. *Automobile liability:* Contractor shall purchase and maintain automobile liability insurance against claims for damages because of bodily injury or death of any person or property damage arising out of the ownership, maintenance, or use of any motor vehicle. The automobile liability policy shall be written on an occurrence basis.
- E. *Umbrella or excess liability:* Contractor shall purchase and maintain umbrella or excess liability insurance written over the underlying employer's liability, commercial general liability, and automobile liability insurance described in the paragraphs above. Subject to industry-standard exclusions, the coverage afforded shall follow form as to each and every one of the underlying policies.
- F. *Contractor's pollution liability insurance:* Contractor shall purchase and maintain a policy covering third-party injury and property damage claims, including clean-up costs, as a result



of pollution conditions arising from Contractor's operations and completed operations. This insurance shall be maintained for no less than three years after final completion.

- G. *Additional insureds*: The Contractor's commercial general liability, automobile liability, umbrella or excess, and pollution liability policies shall include and list as additional insureds Owner and Engineer, and any individuals or entities identified in the Supplementary Conditions; include coverage for the respective officers, directors, members, partners, employees, agents, consultants, and subcontractors of each and any of all such additional insureds; and the insurance afforded to these additional insureds shall provide primary coverage for all claims covered thereby (including as applicable those arising from both ongoing and completed operations) on a non-contributory basis. Contractor shall obtain all necessary endorsements to support these requirements.
- H. *Contractor's professional liability insurance*: If Contractor will provide or furnish professional services under this Contract, through a delegation of professional design services or otherwise, then Contractor shall be responsible for purchasing and maintaining applicable professional liability insurance. This insurance shall provide protection against claims arising out of performance of professional design or related services, and caused by a negligent error, omission, or act for which the insured party is legally liable. It shall be maintained throughout the duration of the Contract and for a minimum of two years after Substantial Completion. If such professional design services are performed by a Subcontractor, and not by Contractor itself, then the requirements of this paragraph may be satisfied through the purchasing and maintenance of such insurance by such Subcontractor.
- I. *General provisions*: The policies of insurance required by this Paragraph 6.03 shall:
  - 1. include at least the specific coverages provided in this Article.
  - 2. be written for not less than the limits of liability provided in this Article and in the Supplementary Conditions, or required by Laws or Regulations, whichever is greater.
  - 3. contain a provision or endorsement that the coverage afforded will not be canceled, materially changed, or renewal refused until at least 10 days prior written notice has been given to Contractor. Within three days of receipt of any such written notice, Contractor shall provide a copy of the notice to Owner, Engineer, and each other insured under the policy.
  - 4. remain in effect at least until final payment (and longer if expressly required in this Article) and at all times thereafter when Contractor may be correcting, removing, or replacing defective Work as a warranty or correction obligation, or otherwise, or returning to the Site to conduct other tasks arising from the Contract Documents.
  - 5. be appropriate for the Work being performed and provide protection from claims that may arise out of or result from Contractor's performance of the Work and Contractor's other obligations under the Contract Documents, whether it is to be performed by Contractor, any Subcontractor or Supplier, or by anyone directly or indirectly employed by any of them to perform any of the Work, or by anyone for whose acts any of them may be liable.
- J. The coverage requirements for specific policies of insurance must be met by such policies, and not by reference to excess or umbrella insurance provided in other policies.

#### 6.04 *Owner's Liability Insurance*

- A. In addition to the insurance required to be provided by Contractor under Paragraph 6.03, Owner, at Owner's option, may purchase and maintain at Owner's expense Owner's own liability insurance as will protect Owner against claims which may arise from operations under the Contract Documents.
- B. Owner's liability policies, if any, operate separately and independently from policies required to be provided by Contractor, and Contractor cannot rely upon Owner's liability policies for any of Contractor's obligations to the Owner, Engineer, or third parties.

#### 6.05 *Property Insurance*

- A. *Builder's Risk*: Unless otherwise provided in the Supplementary Conditions, Contractor shall purchase and maintain builder's risk insurance upon the Work on a completed value basis, in the amount of the full insurable replacement cost thereof (subject to such deductible amounts as may be provided in the Supplementary Conditions or required by Laws and Regulations). This insurance shall:
  - 1. include the Owner and Contractor as named insureds, and all Subcontractors, and any individuals or entities required by the Supplementary Conditions to be insured under such builder's risk policy, as insureds or named insureds. For purposes of the remainder of this Paragraph 6.05, Paragraphs 6.06 and 6.07, and any corresponding Supplementary Conditions, the parties required to be insured shall collectively be referred to as "insureds."
  - 2. be written on a builder's risk "all risk" policy form that shall at least include insurance for physical loss or damage to the Work, temporary buildings, falsework, and materials and equipment in transit, and shall insure against at least the following perils or causes of loss: fire; lightning; windstorm; riot; civil commotion; terrorism; vehicle impact; aircraft; smoke; theft; vandalism and malicious mischief; mechanical breakdown, boiler explosion, and artificially generated electric current; earthquake; volcanic activity, and other earth movement; flood; collapse; explosion; debris removal; demolition occasioned by enforcement of Laws and Regulations; water damage (other than that caused by flood); and such other perils or causes of loss as may be specifically required by the Supplementary Conditions. If insurance against mechanical breakdown, boiler explosion, and artificially generated electric current; earthquake; volcanic activity, and other earth movement; or flood, are not commercially available under builder's risk policies, by endorsement or otherwise, such insurance may be provided through other insurance policies acceptable to Owner and Contractor.
  - 3. cover, as insured property, at least the following: (a) the Work and all materials, supplies, machinery, apparatus, equipment, fixtures, and other property of a similar nature that are to be incorporated into or used in the preparation, fabrication, construction, erection, or completion of the Work, including Owner-furnished or assigned property; (b) spare parts inventory required within the scope of the Contract; and (c) temporary works which are not intended to form part of the permanent constructed Work but which are intended to provide working access to the Site, or to the Work under construction, or which are intended to provide temporary support for the Work under construction, including scaffolding, form work, fences, shoring, falsework, and temporary structures.
  - 4. cover expenses incurred in the repair or replacement of any insured property (including but not limited to fees and charges of engineers and architects).

5. extend to cover damage or loss to insured property while in temporary storage at the Site or in a storage location outside the Site (but not including property stored at the premises of a manufacturer or Supplier).
  6. extend to cover damage or loss to insured property while in transit.
  7. allow for partial occupation or use of the Work by Owner, such that those portions of the Work that are not yet occupied or used by Owner shall remain covered by the builder's risk insurance.
  8. allow for the waiver of the insurer's subrogation rights, as set forth below.
  9. provide primary coverage for all losses and damages caused by the perils or causes of loss covered.
  10. not include a co-insurance clause.
  11. include an exception for ensuing losses from physical damage or loss with respect to any defective workmanship, design, or materials exclusions.
  12. include performance/hot testing and start-up.
  13. be maintained in effect, subject to the provisions herein regarding Substantial Completion and partial occupancy or use of the Work by Owner, until the Work is complete.
- B. *Notice of Cancellation or Change:* All the policies of insurance (and the certificates or other evidence thereof) required to be purchased and maintained in accordance with this Paragraph 6.05 will contain a provision or endorsement that the coverage afforded will not be canceled or materially changed or renewal refused until at least 10 days prior written notice has been given to the purchasing policyholder. Within three days of receipt of any such written notice, the purchasing policyholder shall provide a copy of the notice to each other insured.
- C. *Deductibles:* The purchaser of any required builder's risk or property insurance shall pay for costs not covered because of the application of a policy deductible.
- D. *Partial Occupancy or Use by Owner:* If Owner will occupy or use a portion or portions of the Work prior to Substantial Completion of all the Work as provided in Paragraph 15.04, then Owner (directly, if it is the purchaser of the builder's risk policy, or through Contractor) will provide notice of such occupancy or use to the builder's risk insurer. The builder's risk insurance shall not be canceled or permitted to lapse on account of any such partial use or occupancy; rather, those portions of the Work that are occupied or used by Owner may come off the builder's risk policy, while those portions of the Work not yet occupied or used by Owner shall remain covered by the builder's risk insurance.
- E. *Additional Insurance:* If Contractor elects to obtain other special insurance to be included in or supplement the builder's risk or property insurance policies provided under this Paragraph 6.05, it may do so at Contractor's expense.
- F. *Insurance of Other Property:* If the express insurance provisions of the Contract do not require or address the insurance of a property item or interest, such as tools, construction equipment, or other personal property owned by Contractor, a Subcontractor, or an employee of Contractor or a Subcontractor, then the entity or individual owning such property item will be responsible for deciding whether to insure it, and if so in what amount.

## 6.06 *Waiver of Rights*

- A. All policies purchased in accordance with Paragraph 6.05, expressly including the builder's risk policy, shall contain provisions to the effect that in the event of payment of any loss or damage the insurers will have no rights of recovery against any insureds thereunder, or against Engineer or its consultants, or their officers, directors, members, partners, employees, agents, consultants, or subcontractors. Owner and Contractor waive all rights against each other and the respective officers, directors, members, partners, employees, agents, consultants, and subcontractors of each and any of them, for all losses and damages caused by, arising out of, or resulting from any of the perils or causes of loss covered by such policies and any other property insurance applicable to the Work; and, in addition, waive all such rights against Engineer, its consultants, all Subcontractors, all individuals or entities identified in the Supplementary Conditions as insureds, and the officers, directors, members, partners, employees, agents, consultants, and subcontractors of each and any of them, under such policies for losses and damages so caused. None of the above waivers shall extend to the rights that any party making such waiver may have to the proceeds of insurance held by Owner or Contractor as trustee or fiduciary, or otherwise payable under any policy so issued.
- B. Owner waives all rights against Contractor, Subcontractors, and Engineer, and the officers, directors, members, partners, employees, agents, consultants and subcontractors of each and any of them, for:
  - 1. loss due to business interruption, loss of use, or other consequential loss extending beyond direct physical loss or damage to Owner's property or the Work caused by, arising out of, or resulting from fire or other perils whether or not insured by Owner; and
  - 2. loss or damage to the completed Project or part thereof caused by, arising out of, or resulting from fire or other insured peril or cause of loss covered by any property insurance maintained on the completed Project or part thereof by Owner during partial occupancy or use pursuant to Paragraph 15.04, after Substantial Completion pursuant to Paragraph 15.03, or after final payment pursuant to Paragraph 15.06.
- C. Any insurance policy maintained by Owner covering any loss, damage or consequential loss referred to in Paragraph 6.06.B shall contain provisions to the effect that in the event of payment of any such loss, damage, or consequential loss, the insurers will have no rights of recovery against Contractor, Subcontractors, or Engineer, or the officers, directors, members, partners, employees, agents, consultants, or subcontractors of each and any of them.
- D. Contractor shall be responsible for assuring that the agreement under which a Subcontractor performs a portion of the Work contains provisions whereby the Subcontractor waives all rights against Owner, Contractor, all individuals or entities identified in the Supplementary Conditions as insureds, the Engineer and its consultants, and the officers, directors, members, partners, employees, agents, consultants, and subcontractors of each and any of them, for all losses and damages caused by, arising out of, relating to, or resulting from any of the perils or causes of loss covered by builder's risk insurance and any other property insurance applicable to the Work.

## 6.07 *Receipt and Application of Property Insurance Proceeds*

- A. Any insured loss under the builder's risk and other policies of insurance required by Paragraph 6.05 will be adjusted and settled with the named insured that purchased the

policy. Such named insured shall act as fiduciary for the other insureds, and give notice to such other insureds that adjustment and settlement of a claim is in progress. Any other insured may state its position regarding a claim for insured loss in writing within 15 days after notice of such claim.

- B. Proceeds for such insured losses may be made payable by the insurer either jointly to multiple insureds, or to the named insured that purchased the policy in its own right and as fiduciary for other insureds, subject to the requirements of any applicable mortgage clause. A named insured receiving insurance proceeds under the builder's risk and other policies of insurance required by Paragraph 6.05 shall distribute such proceeds in accordance with such agreement as the parties in interest may reach, or as otherwise required under the dispute resolution provisions of this Contract or applicable Laws and Regulations.
- C. If no other special agreement is reached, the damaged Work shall be repaired or replaced, the money so received applied on account thereof, and the Work and the cost thereof covered by Change Order, if needed.

## **ARTICLE 7 – CONTRACTOR'S RESPONSIBILITIES**

### **7.01 *Supervision and Superintendence***

- A. Contractor shall supervise, inspect, and direct the Work competently and efficiently, devoting such attention thereto and applying such skills and expertise as may be necessary to perform the Work in accordance with the Contract Documents. Contractor shall be solely responsible for the means, methods, techniques, sequences, and procedures of construction.
- B. At all times during the progress of the Work, Contractor shall assign a competent resident superintendent who shall not be replaced without written notice to Owner and Engineer except under extraordinary circumstances.

### **7.02 *Labor; Working Hours***

- A. Contractor shall provide competent, suitably qualified personnel to survey and lay out the Work and perform construction as required by the Contract Documents. Contractor shall at all times maintain good discipline and order at the Site.
- B. Except as otherwise required for the safety or protection of persons or the Work or property at the Site or adjacent thereto, and except as otherwise stated in the Contract Documents, all Work at the Site shall be performed during regular working hours, Monday through Friday. Contractor will not perform Work on a Saturday, Sunday, or any legal holiday. Contractor may perform Work outside regular working hours or on Saturdays, Sundays, or legal holidays only with Owner's written consent, which will not be unreasonably withheld.

### **7.03 *Services, Materials, and Equipment***

- A. Unless otherwise specified in the Contract Documents, Contractor shall provide and assume full responsibility for all services, materials, equipment, labor, transportation, construction equipment and machinery, tools, appliances, fuel, power, light, heat, telephone, water, sanitary facilities, temporary facilities, and all other facilities and incidentals necessary for the performance, testing, start up, and completion of the Work, whether or not such items are specifically called for in the Contract Documents.
- B. All materials and equipment incorporated into the Work shall be of good quality and new, except as otherwise provided in the Contract Documents. All special warranties and

guarantees required by the Specifications shall expressly run to the benefit of Owner. If required by Engineer, Contractor shall furnish satisfactory evidence (including reports of required tests) as to the source, kind, and quality of materials and equipment.

- C. All materials and equipment shall be stored, applied, installed, connected, erected, protected, used, cleaned, and conditioned in accordance with instructions of the applicable Supplier, except as otherwise may be provided in the Contract Documents.

#### 7.04 "Or Equals"

- A. Whenever an item of material or equipment is specified or described in the Contract Documents by using the name of a proprietary item or the name of a particular Supplier, the Contract Price has been based upon Contractor furnishing such item as specified. The specification or description of such an item is intended to establish the type, function, appearance, and quality required. Unless the specification or description contains or is followed by words reading that no like, equivalent, or "or equal" item is permitted, Contractor may request that Engineer authorize the use of other items of material or equipment, or items from other proposed suppliers under the circumstances described below.
  - 1. If Engineer in its sole discretion determines that an item of material or equipment proposed by Contractor is functionally equal to that named and sufficiently similar so that no change in related Work will be required, Engineer shall deem it an "or equal" item. For the purposes of this paragraph, a proposed item of material or equipment will be considered functionally equal to an item so named if:
    - a. in the exercise of reasonable judgment Engineer determines that:
      - 1) it is at least equal in materials of construction, quality, durability, appearance, strength, and design characteristics;
      - 2) it will reliably perform at least equally well the function and achieve the results imposed by the design concept of the completed Project as a functioning whole;
      - 3) it has a proven record of performance and availability of responsive service; and
      - 4) it is not objectionable to Owner.
    - b. Contractor certifies that, if approved and incorporated into the Work:
      - 1) there will be no increase in cost to the Owner or increase in Contract Times; and
      - 2) it will conform substantially to the detailed requirements of the item named in the Contract Documents.
- B. *Contractor's Expense:* Contractor shall provide all data in support of any proposed "or equal" item at Contractor's expense.
- C. *Engineer's Evaluation and Determination:* Engineer will be allowed a reasonable time to evaluate each "or-equal" request. Engineer may require Contractor to furnish additional data about the proposed "or-equal" item. Engineer will be the sole judge of acceptability. No "or-equal" item will be ordered, furnished, installed, or utilized until Engineer's review is complete and Engineer determines that the proposed item is an "or-equal", which will be evidenced by an approved Shop Drawing or other written communication. Engineer will advise Contractor in writing of any negative determination.

- D. *Effect of Engineer's Determination:* Neither approval nor denial of an "or-equal" request shall result in any change in Contract Price. The Engineer's denial of an "or-equal" request shall be final and binding, and may not be reversed through an appeal under any provision of the Contract Documents.
- E. *Treatment as a Substitution Request:* If Engineer determines that an item of material or equipment proposed by Contractor does not qualify as an "or-equal" item, Contractor may request that Engineer consider the proposed item as a substitute pursuant to Paragraph 7.05.

#### 7.05 *Substitutes*

- A. Unless the specification or description of an item of material or equipment required to be furnished under the Contract Documents contains or is followed by words reading that no substitution is permitted, Contractor may request that Engineer authorize the use of other items of material or equipment under the circumstances described below. To the extent possible such requests shall be made before commencement of related construction at the Site.
  - 1. Contractor shall submit sufficient information as provided below to allow Engineer to determine if the item of material or equipment proposed is functionally equivalent to that named and an acceptable substitute therefor. Engineer will not accept requests for review of proposed substitute items of material or equipment from anyone other than Contractor.
  - 2. The requirements for review by Engineer will be as set forth in Paragraph 7.05.B, as supplemented by the Specifications, and as Engineer may decide is appropriate under the circumstances.
  - 3. Contractor shall make written application to Engineer for review of a proposed substitute item of material or equipment that Contractor seeks to furnish or use. The application:
    - a. shall certify that the proposed substitute item will:
      - 1) perform adequately the functions and achieve the results called for by the general design,
      - 2) be similar in substance to that specified, and
      - 3) be suited to the same use as that specified.
    - b. will state:
      - 1) the extent, if any, to which the use of the proposed substitute item will necessitate a change in Contract Times,
      - 2) whether use of the proposed substitute item in the Work will require a change in any of the Contract Documents (or in the provisions of any other direct contract with Owner for other work on the Project) to adapt the design to the proposed substitute item, and
      - 3) whether incorporation or use of the proposed substitute item in connection with the Work is subject to payment of any license fee or royalty.
    - c. will identify:
      - 1) all variations of the proposed substitute item from that specified, and

- 2) available engineering, sales, maintenance, repair, and replacement services.
  - d. shall contain an itemized estimate of all costs or credits that will result directly or indirectly from use of such substitute item, including but not limited to changes in Contract Price, shared savings, costs of redesign, and claims of other contractors affected by any resulting change.
- B. *Engineer's Evaluation and Determination:* Engineer will be allowed a reasonable time to evaluate each substitute request, and to obtain comments and direction from Owner. Engineer may require Contractor to furnish additional data about the proposed substitute item. Engineer will be the sole judge of acceptability. No substitute will be ordered, furnished, installed, or utilized until Engineer's review is complete and Engineer determines that the proposed item is an acceptable substitute. Engineer's determination will be evidenced by a Field Order or a proposed Change Order accounting for the substitution itself and all related impacts, including changes in Contract Price or Contract Times. Engineer will advise Contractor in writing of any negative determination.
  - C. *Special Guarantee:* Owner may require Contractor to furnish at Contractor's expense a special performance guarantee or other surety with respect to any substitute.
  - D. *Reimbursement of Engineer's Cost:* Engineer will record Engineer's costs in evaluating a substitute proposed or submitted by Contractor. Whether or not Engineer approves a substitute so proposed or submitted by Contractor, Contractor shall reimburse Owner for the reasonable charges of Engineer for evaluating each such proposed substitute. Contractor shall also reimburse Owner for the reasonable charges of Engineer for making changes in the Contract Documents (or in the provisions of any other direct contract with Owner) resulting from the acceptance of each proposed substitute.
  - E. *Contractor's Expense:* Contractor shall provide all data in support of any proposed substitute at Contractor's expense.
  - F. *Effect of Engineer's Determination:* If Engineer approves the substitution request, Contractor shall execute the proposed Change Order and proceed with the substitution. The Engineer's denial of a substitution request shall be final and binding, and may not be reversed through an appeal under any provision of the Contract Documents. Contractor may challenge the scope of reimbursement costs imposed under Paragraph 7.05.D, by timely submittal of a Change Proposal.

#### 7.06 *Concerning Subcontractors, Suppliers, and Others*

- A. Contractor may retain Subcontractors and Suppliers for the performance of parts of the Work. Such Subcontractors and Suppliers must be acceptable to Owner.
- B. Contractor shall retain specific Subcontractors, Suppliers, or other individuals or entities for the performance of designated parts of the Work if required by the Contract to do so.
- C. Subsequent to the submittal of Contractor's Bid or final negotiation of the terms of the Contract, Owner may not require Contractor to retain any Subcontractor, Supplier, or other individual or entity to furnish or perform any of the Work against which Contractor has reasonable objection.
- D. Prior to entry into any binding subcontract or purchase order, Contractor shall submit to Owner the identity of the proposed Subcontractor or Supplier (unless Owner has already deemed such proposed Subcontractor or Supplier acceptable, during the bidding process or otherwise). Such proposed Subcontractor or Supplier shall be deemed acceptable to Owner unless Owner raises a substantive, reasonable objection within five days.



- E. Owner may require the replacement of any Subcontractor, Supplier, or other individual or entity retained by Contractor to perform any part of the Work. Owner also may require Contractor to retain specific replacements; provided, however, that Owner may not require a replacement to which Contractor has a reasonable objection. If Contractor has submitted the identity of certain Subcontractors, Suppliers, or other individuals or entities for acceptance by Owner, and Owner has accepted it (either in writing or by failing to make written objection thereto), then Owner may subsequently revoke the acceptance of any such Subcontractor, Supplier, or other individual or entity so identified solely on the basis of substantive, reasonable objection after due investigation. Contractor shall submit an acceptable replacement for the rejected Subcontractor, Supplier, or other individual or entity.
- F. If Owner requires the replacement of any Subcontractor, Supplier, or other individual or entity retained by Contractor to perform any part of the Work, then Contractor shall be entitled to an adjustment in Contract Price or Contract Times, or both, with respect to the replacement; and Contractor shall initiate a Change Proposal for such adjustment within 30 days of Owner's requirement of replacement.
- G. No acceptance by Owner of any such Subcontractor, Supplier, or other individual or entity, whether initially or as a replacement, shall constitute a waiver of the right of Owner to the completion of the Work in accordance with the Contract Documents.
- H. On a monthly basis Contractor shall submit to Engineer a complete list of all Subcontractors and Suppliers having a direct contract with Contractor, and of all other Subcontractors and Suppliers known to Contractor at the time of submittal.
- I. Contractor shall be fully responsible to Owner and Engineer for all acts and omissions of the Subcontractors, Suppliers, and other individuals or entities performing or furnishing any of the Work just as Contractor is responsible for Contractor's own acts and omissions.
- J. Contractor shall be solely responsible for scheduling and coordinating the work of Subcontractors, Suppliers, and all other individuals or entities performing or furnishing any of the Work.
- K. Contractor shall restrict all Subcontractors, Suppliers, and such other individuals or entities performing or furnishing any of the Work from communicating with Engineer or Owner, except through Contractor or in case of an emergency, or as otherwise expressly allowed herein.
- L. The divisions and sections of the Specifications and the identifications of any Drawings shall not control Contractor in dividing the Work among Subcontractors or Suppliers or delineating the Work to be performed by any specific trade.
- M. All Work performed for Contractor by a Subcontractor or Supplier shall be pursuant to an appropriate contractual agreement that specifically binds the Subcontractor or Supplier to the applicable terms and conditions of the Contract Documents for the benefit of Owner and Engineer.
- N. Owner may furnish to any Subcontractor or Supplier, to the extent practicable, information about amounts paid to Contractor on account of Work performed for Contractor by the particular Subcontractor or Supplier.

- O. Nothing in the Contract Documents:
1. shall create for the benefit of any such Subcontractor, Supplier, or other individual or entity any contractual relationship between Owner or Engineer and any such Subcontractor, Supplier, or other individual or entity; nor
  2. shall create any obligation on the part of Owner or Engineer to pay or to see to the payment of any money due any such Subcontractor, Supplier, or other individual or entity except as may otherwise be required by Laws and Regulations.

7.07 *Patent Fees and Royalties*

- A. Contractor shall pay all license fees and royalties and assume all costs incident to the use in the performance of the Work or the incorporation in the Work of any invention, design, process, product, or device which is the subject of patent rights or copyrights held by others. If a particular invention, design, process, product, or device is specified in the Contract Documents for use in the performance of the Work and if, to the actual knowledge of Owner or Engineer, its use is subject to patent rights or copyrights calling for the payment of any license fee or royalty to others, the existence of such rights shall be disclosed by Owner in the Contract Documents.
- B. To the fullest extent permitted by Laws and Regulations, Owner shall indemnify and hold harmless Contractor, and its officers, directors, members, partners, employees, agents, consultants, and subcontractors from and against all claims, costs, losses, and damages (including but not limited to all fees and charges of engineers, architects, attorneys, and other professionals, and all court or arbitration or other dispute resolution costs) arising out of or relating to any infringement of patent rights or copyrights incident to the use in the performance of the Work or resulting from the incorporation in the Work of any invention, design, process, product, or device specified in the Contract Documents, but not identified as being subject to payment of any license fee or royalty to others required by patent rights or copyrights.
- C. To the fullest extent permitted by Laws and Regulations, Contractor shall indemnify and hold harmless Owner and Engineer, and the officers, directors, members, partners, employees, agents, consultants and subcontractors of each and any of them from and against all claims, costs, losses, and damages (including but not limited to all fees and charges of engineers, architects, attorneys, and other professionals and all court or arbitration or other dispute resolution costs) arising out of or relating to any infringement of patent rights or copyrights incident to the use in the performance of the Work or resulting from the incorporation in the Work of any invention, design, process, product, or device not specified in the Contract Documents.

7.08 *Permits*

- A. Unless otherwise provided in the Contract Documents, Contractor shall obtain and pay for all construction permits and licenses. Owner shall assist Contractor, when necessary, in obtaining such permits and licenses. Contractor shall pay all governmental charges and inspection fees necessary for the prosecution of the Work which are applicable at the time of the submission of Contractor's Bid (or when Contractor became bound under a negotiated contract). Owner shall pay all charges of utility owners for connections for providing permanent service to the Work

#### 7.09 *Taxes*

- A. Contractor shall pay all sales, consumer, use, and other similar taxes required to be paid by Contractor in accordance with the Laws and Regulations of the place of the Project which are applicable during the performance of the Work.

#### 7.10 *Laws and Regulations*

- A. Contractor shall give all notices required by and shall comply with all Laws and Regulations applicable to the performance of the Work. Except where otherwise expressly required by applicable Laws and Regulations, neither Owner nor Engineer shall be responsible for monitoring Contractor's compliance with any Laws or Regulations.
- B. If Contractor performs any Work or takes any other action knowing or having reason to know that it is contrary to Laws or Regulations, Contractor shall bear all resulting costs and losses, and shall indemnify and hold harmless Owner and Engineer, and the officers, directors, members, partners, employees, agents, consultants, and subcontractors of each and any of them from and against all claims, costs, losses, and damages (including but not limited to all fees and charges of engineers, architects, attorneys, and other professionals and all court or arbitration or other dispute resolution costs) arising out of or relating to such Work or other action. It shall not be Contractor's responsibility to make certain that the Work described in the Contract Documents is in accordance with Laws and Regulations, but this shall not relieve Contractor of Contractor's obligations under Paragraph 3.03.
- C. Owner or Contractor may give notice to the other party of any changes after the submission of Contractor's Bid (or after the date when Contractor became bound under a negotiated contract) in Laws or Regulations having an effect on the cost or time of performance of the Work, including but not limited to changes in Laws or Regulations having an effect on procuring permits and on sales, use, value-added, consumption, and other similar taxes. If Owner and Contractor are unable to agree on entitlement to or on the amount or extent, if any, of any adjustment in Contract Price or Contract Times resulting from such changes, then within 30 days of such notice Contractor may submit a Change Proposal, or Owner may initiate a Claim.

#### 7.11 *Record Documents*

- A. Contractor shall maintain in a safe place at the Site one printed record copy of all Drawings, Specifications, Addenda, Change Orders, Work Change Directives, Field Orders, written interpretations and clarifications, and approved Shop Drawings. Contractor shall keep such record documents in good order and annotate them to show changes made during construction. These record documents, together with all approved Samples, will be available to Engineer for reference. Upon completion of the Work, Contractor shall deliver these record documents to Engineer.

#### 7.12 *Safety and Protection*

- A. Contractor shall be solely responsible for initiating, maintaining, and supervising all safety precautions and programs in connection with the Work. Such responsibility does not relieve Subcontractors of their responsibility for the safety of persons or property in the performance of their work, nor for compliance with applicable safety Laws and Regulations. Contractor shall take all necessary precautions for the safety of, and shall provide the necessary protection to prevent damage, injury, or loss to:
  - 1. all persons on the Site or who may be affected by the Work;

2. all the Work and materials and equipment to be incorporated therein, whether in storage on or off the Site; and
  3. other property at the Site or adjacent thereto, including trees, shrubs, lawns, walks, pavements, roadways, structures, other work in progress, utilities, and Underground Facilities not designated for removal, relocation, or replacement in the course of construction.
- B. Contractor shall comply with all applicable Laws and Regulations relating to the safety of persons or property, or to the protection of persons or property from damage, injury, or loss; and shall erect and maintain all necessary safeguards for such safety and protection. Contractor shall notify Owner; the owners of adjacent property, Underground Facilities, and other utilities; and other contractors and utility owners performing work at or adjacent to the Site, when prosecution of the Work may affect them, and shall cooperate with them in the protection, removal, relocation, and replacement of their property or work in progress.
  - C. Contractor shall comply with the applicable requirements of Owner's safety programs, if any. The Supplementary Conditions identify any Owner's safety programs that are applicable to the Work.
  - D. Contractor shall inform Owner and Engineer of the specific requirements of Contractor's safety program with which Owner's and Engineer's employees and representatives must comply while at the Site.
  - E. All damage, injury, or loss to any property referred to in Paragraph 7.12.A.2 or 7.12.A.3 caused, directly or indirectly, in whole or in part, by Contractor, any Subcontractor, Supplier, or any other individual or entity directly or indirectly employed by any of them to perform any of the Work, or anyone for whose acts any of them may be liable, shall be remedied by Contractor at its expense (except damage or loss attributable to the fault of Drawings or Specifications or to the acts or omissions of Owner or Engineer or anyone employed by any of them, or anyone for whose acts any of them may be liable, and not attributable, directly or indirectly, in whole or in part, to the fault or negligence of Contractor or any Subcontractor, Supplier, or other individual or entity directly or indirectly employed by any of them).
  - F. Contractor's duties and responsibilities for safety and protection shall continue until such time as all the Work is completed and Engineer has issued a notice to Owner and Contractor in accordance with Paragraph 15.06.B that the Work is acceptable (except as otherwise expressly provided in connection with Substantial Completion).
  - G. Contractor's duties and responsibilities for safety and protection shall resume whenever Contractor or any Subcontractor or Supplier returns to the Site to fulfill warranty or correction obligations, or to conduct other tasks arising from the Contract Documents.

#### 7.13 *Safety Representative*

- A. Contractor shall designate a qualified and experienced safety representative at the Site whose duties and responsibilities shall be the prevention of accidents and the maintaining and supervising of safety precautions and programs.

#### 7.14 *Hazard Communication Programs*

- A. Contractor shall be responsible for coordinating any exchange of material safety data sheets or other hazard communication information required to be made available to or

exchanged between or among employers at the Site in accordance with Laws or Regulations.

#### 7.15 *Emergencies*

- A. In emergencies affecting the safety or protection of persons or the Work or property at the Site or adjacent thereto, Contractor is obligated to act to prevent threatened damage, injury, or loss. Contractor shall give Engineer prompt written notice if Contractor believes that any significant changes in the Work or variations from the Contract Documents have been caused thereby or are required as a result thereof. If Engineer determines that a change in the Contract Documents is required because of the action taken by Contractor in response to such an emergency, a Work Change Directive or Change Order will be issued.

#### 7.16 *Shop Drawings, Samples, and Other Submittals*

##### A. *Shop Drawing and Sample Submittal Requirements:*

1. Before submitting a Shop Drawing or Sample, Contractor shall have:
  - a. reviewed and coordinated the Shop Drawing or Sample with other Shop Drawings and Samples and with the requirements of the Work and the Contract Documents;
  - b. determined and verified all field measurements, quantities, dimensions, specified performance and design criteria, installation requirements, materials, catalog numbers, and similar information with respect thereto;
  - c. determined and verified the suitability of all materials and equipment offered with respect to the indicated application, fabrication, shipping, handling, storage, assembly, and installation pertaining to the performance of the Work; and
  - d. determined and verified all information relative to Contractor's responsibilities for means, methods, techniques, sequences, and procedures of construction, and safety precautions and programs incident thereto.
2. Each submittal shall bear a stamp or specific written certification that Contractor has satisfied Contractor's obligations under the Contract Documents with respect to Contractor's review of that submittal, and that Contractor approves the submittal.
3. With each submittal, Contractor shall give Engineer specific written notice of any variations that the Shop Drawing or Sample may have from the requirements of the Contract Documents. This notice shall be set forth in a written communication separate from the Shop Drawings or Sample submittal; and, in addition, in the case of Shop Drawings by a specific notation made on each Shop Drawing submitted to Engineer for review and approval of each such variation.

- B. *Submittal Procedures for Shop Drawings and Samples:* Contractor shall submit Shop Drawings and Samples to Engineer for review and approval in accordance with the accepted Schedule of Submittals. Each submittal will be identified as Engineer may require.

##### 1. *Shop Drawings:*

- a. Contractor shall submit the number of copies required in the Specifications.
- b. Data shown on the Shop Drawings will be complete with respect to quantities, dimensions, specified performance and design criteria, materials, and similar data to show Engineer the services, materials, and equipment Contractor proposes to

provide and to enable Engineer to review the information for the limited purposes required by Paragraph 7.16.D.

2. *Samples:*
  - a. Contractor shall submit the number of Samples required in the Specifications.
  - b. Contractor shall clearly identify each Sample as to material, Supplier, pertinent data such as catalog numbers, the use for which intended and other data as Engineer may require to enable Engineer to review the submittal for the limited purposes required by Paragraph 7.16.D.
3. Where a Shop Drawing or Sample is required by the Contract Documents or the Schedule of Submittals, any related Work performed prior to Engineer's review and approval of the pertinent submittal will be at the sole expense and responsibility of Contractor.
- C. *Other Submittals:* Contractor shall submit other submittals to Engineer in accordance with the accepted Schedule of Submittals, and pursuant to the applicable terms of the Specifications.
- D. *Engineer's Review:*
  1. Engineer will provide timely review of Shop Drawings and Samples in accordance with the Schedule of Submittals acceptable to Engineer. Engineer's review and approval will be only to determine if the items covered by the submittals will, after installation or incorporation in the Work, conform to the information given in the Contract Documents and be compatible with the design concept of the completed Project as a functioning whole as indicated by the Contract Documents.
  2. Engineer's review and approval will not extend to means, methods, techniques, sequences, or procedures of construction or to safety precautions or programs incident thereto.
  3. Engineer's review and approval of a separate item as such will not indicate approval of the assembly in which the item functions.
  4. Engineer's review and approval of a Shop Drawing or Sample shall not relieve Contractor from responsibility for any variation from the requirements of the Contract Documents unless Contractor has complied with the requirements of Paragraph 7.16.A.3 and Engineer has given written approval of each such variation by specific written notation thereof incorporated in or accompanying the Shop Drawing or Sample. Engineer will document any such approved variation from the requirements of the Contract Documents in a Field Order.
  5. Engineer's review and approval of a Shop Drawing or Sample shall not relieve Contractor from responsibility for complying with the requirements of Paragraph 7.16.A and B.
  6. Engineer's review and approval of a Shop Drawing or Sample, or of a variation from the requirements of the Contract Documents, shall not, under any circumstances, change the Contract Times or Contract Price, unless such changes are included in a Change Order.
  7. Neither Engineer's receipt, review, acceptance or approval of a Shop Drawing, Sample, or other submittal shall result in such item becoming a Contract Document.

8. Contractor shall perform the Work in compliance with the requirements and commitments set forth in approved Shop Drawings and Samples, subject to the provisions of Paragraph 7.16.D.4.

E. *Resubmittal Procedures:*

1. Contractor shall make corrections required by Engineer and shall return the required number of corrected copies of Shop Drawings and submit, as required, new Samples for review and approval. Contractor shall direct specific attention in writing to revisions other than the corrections called for by Engineer on previous submittals.
2. Contractor shall furnish required submittals with sufficient information and accuracy to obtain required approval of an item with no more than three submittals. Engineer will record Engineer's time for reviewing a fourth or subsequent submittal of a Shop Drawings, sample, or other item requiring approval, and Contractor shall be responsible for Engineer's charges to Owner for such time. Owner may impose a set-off against payments due to Contractor to secure reimbursement for such charges.
3. If Contractor requests a change of a previously approved submittal item, Contractor shall be responsible for Engineer's charges to Owner for its review time, and Owner may impose a set-off against payments due to Contractor to secure reimbursement for such charges, unless the need for such change is beyond the control of Contractor.

7.17 *Contractor's General Warranty and Guarantee*

- A. Contractor warrants and guarantees to Owner that all Work will be in accordance with the Contract Documents and will not be defective. Engineer and its officers, directors, members, partners, employees, agents, consultants, and subcontractors shall be entitled to rely on Contractor's warranty and guarantee.
- B. Contractor's warranty and guarantee hereunder excludes defects or damage caused by:
  1. abuse, modification, or improper maintenance or operation by persons other than Contractor, Subcontractors, Suppliers, or any other individual or entity for whom Contractor is responsible; or
  2. normal wear and tear under normal usage.
- C. Contractor's obligation to perform and complete the Work in accordance with the Contract Documents shall be absolute. None of the following will constitute an acceptance of Work that is not in accordance with the Contract Documents or a release of Contractor's obligation to perform the Work in accordance with the Contract Documents:
  1. observations by Engineer;
  2. recommendation by Engineer or payment by Owner of any progress or final payment;
  3. the issuance of a certificate of Substantial Completion by Engineer or any payment related thereto by Owner;
  4. use or occupancy of the Work or any part thereof by Owner;
  5. any review and approval of a Shop Drawing or Sample submittal;
  6. the issuance of a notice of acceptability by Engineer;
  7. any inspection, test, or approval by others; or
  8. any correction of defective Work by Owner.

- D. If the Contract requires the Contractor to accept the assignment of a contract entered into by Owner, then the specific warranties, guarantees, and correction obligations contained in the assigned contract shall govern with respect to Contractor's performance obligations to Owner for the Work described in the assigned contract.

#### 7.18 *Indemnification*

- A. To the fullest extent permitted by Laws and Regulations, and in addition to any other obligations of Contractor under the Contract or otherwise, Contractor shall indemnify and hold harmless Owner and Engineer, and the officers, directors, members, partners, employees, agents, consultants and subcontractors of each and any of them from and against all claims, costs, losses, and damages (including but not limited to all fees and charges of engineers, architects, attorneys, and other professionals and all court or arbitration or other dispute resolution costs) arising out of or relating to the performance of the Work, provided that any such claim, cost, loss, or damage is attributable to bodily injury, sickness, disease, or death, or to injury to or destruction of tangible property (other than the Work itself), including the loss of use resulting therefrom but only to the extent caused by any negligent act or omission of Contractor, any Subcontractor, any Supplier, or any individual or entity directly or indirectly employed by any of them to perform any of the Work or anyone for whose acts any of them may be liable.
- B. In any and all claims against Owner or Engineer or any of their officers, directors, members, partners, employees, agents, consultants, or subcontractors by any employee (or the survivor or personal representative of such employee) of Contractor, any Subcontractor, any Supplier, or any individual or entity directly or indirectly employed by any of them to perform any of the Work, or anyone for whose acts any of them may be liable, the indemnification obligation under Paragraph 7.18.A shall not be limited in any way by any limitation on the amount or type of damages, compensation, or benefits payable by or for Contractor or any such Subcontractor, Supplier, or other individual or entity under workers' compensation acts, disability benefit acts, or other employee benefit acts.
- C. The indemnification obligations of Contractor under Paragraph 7.18.A shall not extend to the liability of Engineer and Engineer's officers, directors, members, partners, employees, agents, consultants and subcontractors arising out of:
  - 1. the preparation or approval of, or the failure to prepare or approve maps, Drawings, opinions, reports, surveys, Change Orders, designs, or Specifications; or
  - 2. giving directions or instructions, or failing to give them, if that is the primary cause of the injury or damage.

#### 7.19 *Delegation of Professional Design Services*

- A. Contractor will not be required to provide professional design services unless such services are specifically required by the Contract Documents for a portion of the Work or unless such services are required to carry out Contractor's responsibilities for construction means, methods, techniques, sequences and procedures. Contractor shall not be required to provide professional services in violation of applicable Laws and Regulations.
- B. If professional design services or certifications by a design professional related to systems, materials, or equipment are specifically required of Contractor by the Contract Documents, Owner and Engineer will specify all performance and design criteria that such services must satisfy. Contractor shall cause such services or certifications to be provided by a properly licensed professional, whose signature and seal shall appear on all drawings, calculations, specifications, certifications, and other submittals prepared by such professional. Shop



Drawings and other submittals related to the Work designed or certified by such professional, if prepared by others, shall bear such professional's written approval when submitted to Engineer.

- C. Owner and Engineer shall be entitled to rely upon the adequacy, accuracy, and completeness of the services, certifications, or approvals performed by such design professionals, provided Owner and Engineer have specified to Contractor all performance and design criteria that such services must satisfy.
- D. Pursuant to this paragraph, Engineer's review and approval of design calculations and design drawings will be only for the limited purpose of checking for conformance with performance and design criteria given and the design concept expressed in the Contract Documents. Engineer's review and approval of Shop Drawings and other submittals (except design calculations and design drawings) will be only for the purpose stated in Paragraph 7.16.D.1.
- E. Contractor shall not be responsible for the adequacy of the performance or design criteria specified by Owner or Engineer.

## **ARTICLE 8 – OTHER WORK AT THE SITE**

### **8.01 *Other Work***

- A. In addition to and apart from the Work under the Contract Documents, the Owner may perform other work at or adjacent to the Site. Such other work may be performed by Owner's employees, or through contracts between the Owner and third parties. Owner may also arrange to have third-party utility owners perform work on their utilities and facilities at or adjacent to the Site.
- B. If Owner performs other work at or adjacent to the Site with Owner's employees, or through contracts for such other work, then Owner shall give Contractor written notice thereof prior to starting any such other work. If Owner has advance information regarding the start of any utility work at or adjacent to the Site, Owner shall provide such information to Contractor.
- C. Contractor shall afford each other contractor that performs such other work, each utility owner performing other work, and Owner, if Owner is performing other work with Owner's employees, proper and safe access to the Site, and provide a reasonable opportunity for the introduction and storage of materials and equipment and the execution of such other work. Contractor shall do all cutting, fitting, and patching of the Work that may be required to properly connect or otherwise make its several parts come together and properly integrate with such other work. Contractor shall not endanger any work of others by cutting, excavating, or otherwise altering such work; provided, however, that Contractor may cut or alter others' work with the written consent of Engineer and the others whose work will be affected.
- D. If the proper execution or results of any part of Contractor's Work depends upon work performed by others under this Article 8, Contractor shall inspect such other work and promptly report to Engineer in writing any delays, defects, or deficiencies in such other work that render it unavailable or unsuitable for the proper execution and results of Contractor's Work. Contractor's failure to so report will constitute an acceptance of such other work as fit and proper for integration with Contractor's Work except for latent defects and deficiencies in such other work.

## 8.02 *Coordination*

- A. If Owner intends to contract with others for the performance of other work at or adjacent to the Site, to perform other work at or adjacent to the Site with Owner's employees, or to arrange to have utility owners perform work at or adjacent to the Site, the following will be set forth in the Supplementary Conditions or provided to Contractor prior to the start of any such other work:
  - 1. the identity of the individual or entity that will have authority and responsibility for coordination of the activities among the various contractors;
  - 2. an itemization of the specific matters to be covered by such authority and responsibility; and
  - 3. the extent of such authority and responsibilities.
- B. Unless otherwise provided in the Supplementary Conditions, Owner shall have sole authority and responsibility for such coordination.

## 8.03 *Legal Relationships*

- A. If, in the course of performing other work at or adjacent to the Site for Owner, the Owner's employees, any other contractor working for Owner, or any utility owner causes damage to the Work or to the property of Contractor or its Subcontractors, or delays, disrupts, interferes with, or increases the scope or cost of the performance of the Work, through actions or inaction, then Contractor shall be entitled to an equitable adjustment in the Contract Price or the Contract Times, or both. Contractor must submit any Change Proposal seeking an equitable adjustment in the Contract Price or the Contract Times under this paragraph within 30 days of the damaging, delaying, disrupting, or interfering event. The entitlement to, and extent of, any such equitable adjustment shall take into account information (if any) regarding such other work that was provided to Contractor in the Contract Documents prior to the submittal of the Bid or the final negotiation of the terms of the Contract. When applicable, any such equitable adjustment in Contract Price shall be conditioned on Contractor assigning to Owner all Contractor's rights against such other contractor or utility owner with respect to the damage, delay, disruption, or interference that is the subject of the adjustment. Contractor's entitlement to an adjustment of the Contract Times is conditioned on such adjustment being essential to Contractor's ability to complete the Work within the Contract Times.
- B. Contractor shall take reasonable and customary measures to avoid damaging, delaying, disrupting, or interfering with the work of Owner, any other contractor, or any utility owner performing other work at or adjacent to the Site. If Contractor fails to take such measures and as a result damages, delays, disrupts, or interferes with the work of any such other contractor or utility owner, then Owner may impose a set-off against payments due to Contractor, and assign to such other contractor or utility owner the Owner's contractual rights against Contractor with respect to the breach of the obligations set forth in this paragraph.
- C. When Owner is performing other work at or adjacent to the Site with Owner's employees, Contractor shall be liable to Owner for damage to such other work, and for the reasonable direct delay, disruption, and interference costs incurred by Owner as a result of Contractor's failure to take reasonable and customary measures with respect to Owner's other work. In response to such damage, delay, disruption, or interference, Owner may impose a set-off against payments due to Contractor.

- D. If Contractor damages, delays, disrupts, or interferes with the work of any other contractor, or any utility owner performing other work at or adjacent to the Site, through Contractor's failure to take reasonable and customary measures to avoid such impacts, or if any claim arising out of Contractor's actions, inactions, or negligence in performance of the Work at or adjacent to the Site is made by any such other contractor or utility owner against Contractor, Owner, or Engineer, then Contractor shall (1) promptly attempt to settle the claim as to all parties through negotiations with such other contractor or utility owner, or otherwise resolve the claim by arbitration or other dispute resolution proceeding or at law, and (2) indemnify and hold harmless Owner and Engineer, and the officers, directors, members, partners, employees, agents, consultants and subcontractors of each and any of them from and against any such claims, and against all costs, losses, and damages (including but not limited to all fees and charges of engineers, architects, attorneys, and other professionals and all court or arbitration or other dispute resolution costs) arising out of or relating to such damage, delay, disruption, or interference.

## **ARTICLE 9 – OWNER'S RESPONSIBILITIES**

### **9.01 *Communications to Contractor***

- A. Except as otherwise provided in these General Conditions, Owner shall issue all communications to Contractor through Engineer.

### **9.02 *Replacement of Engineer***

- A. Owner may at its discretion appoint an engineer to replace Engineer, provided Contractor makes no reasonable objection to the replacement engineer. The replacement engineer's status under the Contract Documents shall be that of the former Engineer.

### **9.03 *Furnish Data***

- A. Owner shall promptly furnish the data required of Owner under the Contract Documents.

### **9.04 *Pay When Due***

- A. Owner shall make payments to Contractor when they are due as provided in the Agreement.

### **9.05 *Lands and Easements; Reports, Tests, and Drawings***

- A. Owner's duties with respect to providing lands and easements are set forth in Paragraph 5.01.
- B. Owner's duties with respect to providing engineering surveys to establish reference points are set forth in Paragraph 4.03.
- C. Article 5 refers to Owner's identifying and making available to Contractor copies of reports of explorations and tests of conditions at the Site, and drawings of physical conditions relating to existing surface or subsurface structures at the Site.

### **9.06 *Insurance***

- A. Owner's responsibilities, if any, with respect to purchasing and maintaining liability and property insurance are set forth in Article 6.

### **9.07 *Change Orders***

- A. Owner's responsibilities with respect to Change Orders are set forth in Article 11.

9.08 *Inspections, Tests, and Approvals*

- A. Owner's responsibility with respect to certain inspections, tests, and approvals is set forth in Paragraph 14.02.B.

9.09 *Limitations on Owner's Responsibilities*

- A. The Owner shall not supervise, direct, or have control or authority over, nor be responsible for, Contractor's means, methods, techniques, sequences, or procedures of construction, or the safety precautions and programs incident thereto, or for any failure of Contractor to comply with Laws and Regulations applicable to the performance of the Work. Owner will not be responsible for Contractor's failure to perform the Work in accordance with the Contract Documents.

9.10 *Undisclosed Hazardous Environmental Condition*

- A. Owner's responsibility in respect to an undisclosed Hazardous Environmental Condition is set forth in Paragraph 5.06.

9.11 *Evidence of Financial Arrangements*

- A. Upon request of Contractor, Owner shall furnish Contractor reasonable evidence that financial arrangements have been made to satisfy Owner's obligations under the Contract Documents (including obligations under proposed changes in the Work).

9.12 *Safety Programs*

- A. While at the Site, Owner's employees and representatives shall comply with the specific applicable requirements of Contractor's safety programs of which Owner has been informed.
- B. Owner shall furnish copies of any applicable Owner safety programs to Contractor.

**ARTICLE 10 – ENGINEER'S STATUS DURING CONSTRUCTION**

10.01 *Owner's Representative*

- A. Engineer will be Owner's representative during the construction period. The duties and responsibilities and the limitations of authority of Engineer as Owner's representative during construction are set forth in the Contract.

10.02 *Visits to Site*

- A. Engineer will make visits to the Site at intervals appropriate to the various stages of construction as Engineer deems necessary in order to observe as an experienced and qualified design professional the progress that has been made and the quality of the various aspects of Contractor's executed Work. Based on information obtained during such visits and observations, Engineer, for the benefit of Owner, will determine, in general, if the Work is proceeding in accordance with the Contract Documents. Engineer will not be required to make exhaustive or continuous inspections on the Site to check the quality or quantity of the Work. Engineer's efforts will be directed toward providing for Owner a greater degree of confidence that the completed Work will conform generally to the Contract Documents. On the basis of such visits and observations, Engineer will keep Owner informed of the progress of the Work and will endeavor to guard Owner against defective Work.
- B. Engineer's visits and observations are subject to all the limitations on Engineer's authority and responsibility set forth in Paragraph 10.08. Particularly, but without limitation, during

or as a result of Engineer's visits or observations of Contractor's Work, Engineer will not supervise, direct, control, or have authority over or be responsible for Contractor's means, methods, techniques, sequences, or procedures of construction, or the safety precautions and programs incident thereto, or for any failure of Contractor to comply with Laws and Regulations applicable to the performance of the Work.

10.03 *Project Representative*

- A. If Owner and Engineer have agreed that Engineer will furnish a Resident Project Representative to represent Engineer at the Site and assist Engineer in observing the progress and quality of the Work, then the authority and responsibilities of any such Resident Project Representative will be as provided in the Supplementary Conditions, and limitations on the responsibilities thereof will be as provided in Paragraph 10.08. If Owner designates another representative or agent to represent Owner at the Site who is not Engineer's consultant, agent, or employee, the responsibilities and authority and limitations thereon of such other individual or entity will be as provided in the Supplementary Conditions.

10.04 *Rejecting Defective Work*

- A. Engineer has the authority to reject Work in accordance with Article 14.

10.05 *Shop Drawings, Change Orders and Payments*

- A. Engineer's authority, and limitations thereof, as to Shop Drawings and Samples, are set forth in Paragraph 7.16.
- B. Engineer's authority, and limitations thereof, as to design calculations and design drawings submitted in response to a delegation of professional design services, if any, are set forth in Paragraph 7.19.
- C. Engineer's authority as to Change Orders is set forth in Article 11.
- D. Engineer's authority as to Applications for Payment is set forth in Article 15.

10.06 *Determinations for Unit Price Work*

- A. Engineer will determine the actual quantities and classifications of Unit Price Work performed by Contractor as set forth in Paragraph 13.03.

10.07 *Decisions on Requirements of Contract Documents and Acceptability of Work*

- A. Engineer will render decisions regarding the requirements of the Contract Documents, and judge the acceptability of the Work, pursuant to the specific procedures set forth herein for initial interpretations, Change Proposals, and acceptance of the Work. In rendering such decisions and judgments, Engineer will not show partiality to Owner or Contractor, and will not be liable to Owner, Contractor, or others in connection with any proceedings, interpretations, decisions, or judgments conducted or rendered in good faith.

10.08 *Limitations on Engineer's Authority and Responsibilities*

- A. Neither Engineer's authority or responsibility under this Article 10 or under any other provision of the Contract, nor any decision made by Engineer in good faith either to exercise or not exercise such authority or responsibility or the undertaking, exercise, or performance of any authority or responsibility by Engineer, shall create, impose, or give rise to any duty in contract, tort, or otherwise owed by Engineer to Contractor, any Subcontractor, any Supplier, any other individual or entity, or to any surety for or employee or agent of any of them.

- B. Engineer will not supervise, direct, control, or have authority over or be responsible for Contractor's means, methods, techniques, sequences, or procedures of construction, or the safety precautions and programs incident thereto, or for any failure of Contractor to comply with Laws and Regulations applicable to the performance of the Work. Engineer will not be responsible for Contractor's failure to perform the Work in accordance with the Contract Documents.
- C. Engineer will not be responsible for the acts or omissions of Contractor or of any Subcontractor, any Supplier, or of any other individual or entity performing any of the Work.
- D. Engineer's review of the final Application for Payment and accompanying documentation and all maintenance and operating instructions, schedules, guarantees, bonds, certificates of inspection, tests and approvals, and other documentation required to be delivered by Paragraph 15.06.A will only be to determine generally that their content complies with the requirements of, and in the case of certificates of inspections, tests, and approvals, that the results certified indicate compliance with the Contract Documents.
- E. The limitations upon authority and responsibility set forth in this Paragraph 10.08 shall also apply to the Resident Project Representative, if any.

#### 10.09 *Compliance with Safety Program*

- A. While at the Site, Engineer's employees and representatives will comply with the specific applicable requirements of Owner's and Contractor's safety programs (if any) of which Engineer has been informed.

### **ARTICLE 11 – AMENDING THE CONTRACT DOCUMENTS; CHANGES IN THE WORK**

#### 11.01 *Amending and Supplementing Contract Documents*

- A. The Contract Documents may be amended or supplemented by a Change Order, a Work Change Directive, or a Field Order.
  - 1. *Change Orders:*
    - a. If an amendment or supplement to the Contract Documents includes a change in the Contract Price or the Contract Times, such amendment or supplement must be set forth in a Change Order. A Change Order also may be used to establish amendments and supplements of the Contract Documents that do not affect the Contract Price or Contract Times.
    - b. Owner and Contractor may amend those terms and conditions of the Contract Documents that do not involve (1) the performance or acceptability of the Work, (2) the design (as set forth in the Drawings, Specifications, or otherwise), or (3) other engineering or technical matters, without the recommendation of the Engineer. Such an amendment shall be set forth in a Change Order.
  - 2. *Work Change Directives:* A Work Change Directive will not change the Contract Price or the Contract Times but is evidence that the parties expect that the modification ordered or documented by a Work Change Directive will be incorporated in a subsequently issued Change Order, following negotiations by the parties as to the Work Change Directive's effect, if any, on the Contract Price and Contract Times; or, if negotiations are unsuccessful, by a determination under the terms of the Contract Documents governing adjustments, expressly including Paragraph 11.04 regarding change of Contract Price. Contractor must submit any Change Proposal seeking an

adjustment of the Contract Price or the Contract Times, or both, no later than 30 days after the completion of the Work set out in the Work Change Directive. Owner must submit any Claim seeking an adjustment of the Contract Price or the Contract Times, or both, no later than 60 days after issuance of the Work Change Directive.

3. *Field Orders*: Engineer may authorize minor changes in the Work if the changes do not involve an adjustment in the Contract Price or the Contract Times and are compatible with the design concept of the completed Project as a functioning whole as indicated by the Contract Documents. Such changes will be accomplished by a Field Order and will be binding on Owner and also on Contractor, which shall perform the Work involved promptly. If Contractor believes that a Field Order justifies an adjustment in the Contract Price or Contract Times, or both, then before proceeding with the Work at issue, Contractor shall submit a Change Proposal as provided herein.

#### 11.02 *Owner-Authorized Changes in the Work*

- A. Without invalidating the Contract and without notice to any surety, Owner may, at any time or from time to time, order additions, deletions, or revisions in the Work. Such changes shall be supported by Engineer's recommendation, to the extent the change involves the design (as set forth in the Drawings, Specifications, or otherwise), or other engineering or technical matters. Such changes may be accomplished by a Change Order, if Owner and Contractor have agreed as to the effect, if any, of the changes on Contract Times or Contract Price; or by a Work Change Directive. Upon receipt of any such document, Contractor shall promptly proceed with the Work involved; or, in the case of a deletion in the Work, promptly cease construction activities with respect to such deleted Work. Added or revised Work shall be performed under the applicable conditions of the Contract Documents. Nothing in this paragraph shall obligate Contractor to undertake work that Contractor reasonably concludes cannot be performed in a manner consistent with Contractor's safety obligations under the Contract Documents or Laws and Regulations.

#### 11.03 *Unauthorized Changes in the Work*

- A. Contractor shall not be entitled to an increase in the Contract Price or an extension of the Contract Times with respect to any work performed that is not required by the Contract Documents, as amended, modified, or supplemented, except in the case of an emergency as provided in Paragraph 7.15 or in the case of uncovering Work as provided in Paragraph 14.05.

#### 11.04 *Change of Contract Price*

- A. The Contract Price may only be changed by a Change Order. Any Change Proposal for an adjustment in the Contract Price shall comply with the provisions of Paragraph 11.06. Any Claim for an adjustment of Contract Price shall comply with the provisions of Article 12.
- B. An adjustment in the Contract Price will be determined as follows:
  1. where the Work involved is covered by unit prices contained in the Contract Documents, then by application of such unit prices to the quantities of the items involved (subject to the provisions of Paragraph 13.03); or
  2. where the Work involved is not covered by unit prices contained in the Contract Documents, then by a mutually agreed lump sum (which may include an allowance for overhead and profit not necessarily in accordance with Paragraph 11.04.C.2); or
  3. where the Work involved is not covered by unit prices contained in the Contract Documents and the parties do not reach mutual agreement to a lump sum, then on

the basis of the Cost of the Work (determined as provided in Paragraph 13.01) plus a Contractor's fee for overhead and profit (determined as provided in Paragraph 11.04.C).

- C. *Contractor's Fee*: When applicable, the Contractor's fee for overhead and profit shall be determined as follows:
1. a mutually acceptable fixed fee; or
  2. if a fixed fee is not agreed upon, then a fee based on the following percentages of the various portions of the Cost of the Work:
    - a. for costs incurred under Paragraphs 13.01.B.1 and 13.01.B.2, the Contractor's fee shall be 15 percent;
    - b. for costs incurred under Paragraph 13.01.B.3, the Contractor's fee shall be five percent;
    - c. where one or more tiers of subcontracts are on the basis of Cost of the Work plus a fee and no fixed fee is agreed upon, the intent of Paragraphs 11.01.C.2.a and 11.01.C.2.b is that the Contractor's fee shall be based on: (1) a fee of 15 percent of the costs incurred under Paragraphs 13.01.A.1 and 13.01.A.2 by the Subcontractor that actually performs the Work, at whatever tier, and (2) with respect to Contractor itself and to any Subcontractors of a tier higher than that of the Subcontractor that actually performs the Work, a fee of five percent of the amount (fee plus underlying costs incurred) attributable to the next lower tier Subcontractor; provided, however, that for any such subcontracted work the maximum total fee to be paid by Owner shall be no greater than 27 percent of the costs incurred by the Subcontractor that actually performs the work;
    - d. no fee shall be payable on the basis of costs itemized under Paragraphs 13.01.B.4, 13.01.B.5, and 13.01.C;
    - e. the amount of credit to be allowed by Contractor to Owner for any change which results in a net decrease in cost will be the amount of the actual net decrease in cost plus a deduction in Contractor's fee by an amount equal to five percent of such net decrease; and
    - f. when both additions and credits are involved in any one change, the adjustment in Contractor's fee shall be computed on the basis of the net change in accordance with Paragraphs 11.04.C.2.a through 11.04.C.2.e, inclusive.

#### 11.05 *Change of Contract Times*

- A. The Contract Times may only be changed by a Change Order. Any Change Proposal for an adjustment in the Contract Times shall comply with the provisions of Paragraph 11.06. Any Claim for an adjustment in the Contract Times shall comply with the provisions of Article 12.
- B. An adjustment of the Contract Times shall be subject to the limitations set forth in Paragraph 4.05, concerning delays in Contractor's progress.

#### 11.06 *Change Proposals*

- A. Contractor shall submit a Change Proposal to Engineer to request an adjustment in the Contract Times or Contract Price; appeal an initial decision by Engineer concerning the requirements of the Contract Documents or relating to the acceptability of the Work under the Contract Documents; contest a set-off against payment due; or seek other relief under



the Contract. The Change Proposal shall specify any proposed change in Contract Times or Contract Price, or both, or other proposed relief, and explain the reason for the proposed change, with citations to any governing or applicable provisions of the Contract Documents.

1. *Procedures:* Contractor shall submit each Change Proposal to Engineer promptly (but in no event later than 30 days) after the start of the event giving rise thereto, or after such initial decision. The Contractor shall submit supporting data, including the proposed change in Contract Price or Contract Time (if any), to the Engineer and Owner within 15 days after the submittal of the Change Proposal. The supporting data shall be accompanied by a written statement that the supporting data are accurate and complete, and that any requested time or price adjustment is the entire adjustment to which Contractor believes it is entitled as a result of said event. Engineer will advise Owner regarding the Change Proposal, and consider any comments or response from Owner regarding the Change Proposal.
  2. *Engineer's Action:* Engineer will review each Change Proposal and, within 30 days after receipt of the Contractor's supporting data, either deny the Change Proposal in whole, approve it in whole, or deny it in part and approve it in part. Such actions shall be in writing, with a copy provided to Owner and Contractor. If Engineer does not take action on the Change Proposal within 30 days, then either Owner or Contractor may at any time thereafter submit a letter to the other party indicating that as a result of Engineer's inaction the Change Proposal is deemed denied, thereby commencing the time for appeal of the denial under Article 12.
  3. *Binding Decision:* Engineer's decision will be final and binding upon Owner and Contractor, unless Owner or Contractor appeals the decision by filing a Claim under Article 12.
- B. *Resolution of Certain Change Proposals:* If the Change Proposal does not involve the design (as set forth in the Drawings, Specifications, or otherwise), the acceptability of the Work, or other engineering or technical matters, then Engineer will notify the parties that the Engineer is unable to resolve the Change Proposal. For purposes of further resolution of such a Change Proposal, such notice shall be deemed a denial, and Contractor may choose to seek resolution under the terms of Article 12.

#### 11.07 Execution of Change Orders

- A. Owner and Contractor shall execute appropriate Change Orders covering:
1. changes in the Contract Price or Contract Times which are agreed to by the parties, including any undisputed sum or amount of time for Work actually performed in accordance with a Work Change Directive;
  2. changes in Contract Price resulting from an Owner set-off, unless Contractor has duly contested such set-off;
  3. changes in the Work which are: (a) ordered by Owner pursuant to Paragraph 11.02, (b) required because of Owner's acceptance of defective Work under Paragraph 14.04 or Owner's correction of defective Work under Paragraph 14.07, or (c) agreed to by the parties, subject to the need for Engineer's recommendation if the change in the Work involves the design (as set forth in the Drawings, Specifications, or otherwise), or other engineering or technical matters; and
  4. changes in the Contract Price or Contract Times, or other changes, which embody the substance of any final and binding results under Paragraph 11.06, or Article 12.

- B. If Owner or Contractor refuses to execute a Change Order that is required to be executed under the terms of this Paragraph 11.07, it shall be deemed to be of full force and effect, as if fully executed.

#### 11.08 *Notification to Surety*

- A. If the provisions of any bond require notice to be given to a surety of any change affecting the general scope of the Work or the provisions of the Contract Documents (including, but not limited to, Contract Price or Contract Times), the giving of any such notice will be Contractor's responsibility. The amount of each applicable bond will be adjusted to reflect the effect of any such change.

### **ARTICLE 12 – CLAIMS**

#### 12.01 *Claims*

- A. *Claims Process:* The following disputes between Owner and Contractor shall be submitted to the Claims process set forth in this Article:
  - 1. Appeals by Owner or Contractor of Engineer's decisions regarding Change Proposals;
  - 2. Owner demands for adjustments in the Contract Price or Contract Times, or other relief under the Contract Documents; and
  - 3. Disputes that Engineer has been unable to address because they do not involve the design (as set forth in the Drawings, Specifications, or otherwise), the acceptability of the Work, or other engineering or technical matters.
- B. *Submittal of Claim:* The party submitting a Claim shall deliver it directly to the other party to the Contract promptly (but in no event later than 30 days) after the start of the event giving rise thereto; in the case of appeals regarding Change Proposals within 30 days of the decision under appeal. The party submitting the Claim shall also furnish a copy to the Engineer, for its information only. The responsibility to substantiate a Claim shall rest with the party making the Claim. In the case of a Claim by Contractor seeking an increase in the Contract Times or Contract Price, or both, Contractor shall certify that the Claim is made in good faith, that the supporting data are accurate and complete, and that to the best of Contractor's knowledge and belief the amount of time or money requested accurately reflects the full amount to which Contractor is entitled.
- C. *Review and Resolution:* The party receiving a Claim shall review it thoroughly, giving full consideration to its merits. The two parties shall seek to resolve the Claim through the exchange of information and direct negotiations. The parties may extend the time for resolving the Claim by mutual agreement. All actions taken on a Claim shall be stated in writing and submitted to the other party, with a copy to Engineer.
- D. *Mediation:*
  - 1. At any time after initiation of a Claim, Owner and Contractor may mutually agree to mediation of the underlying dispute. The agreement to mediate shall stay the Claim submittal and response process.
  - 2. If Owner and Contractor agree to mediation, then after 60 days from such agreement, either Owner or Contractor may unilaterally terminate the mediation process, and the Claim submittal and decision process shall resume as of the date of the termination. If the mediation proceeds but is unsuccessful in resolving the dispute, the Claim

submittal and decision process shall resume as of the date of the conclusion of the mediation, as determined by the mediator.

3. Owner and Contractor shall each pay one-half of the mediator's fees and costs.
- E. *Partial Approval*: If the party receiving a Claim approves the Claim in part and denies it in part, such action shall be final and binding unless within 30 days of such action the other party invokes the procedure set forth in Article 17 for final resolution of disputes.
- F. *Denial of Claim*: If efforts to resolve a Claim are not successful, the party receiving the Claim may deny it by giving written notice of denial to the other party. If the receiving party does not take action on the Claim within 90 days, then either Owner or Contractor may at any time thereafter submit a letter to the other party indicating that as a result of the inaction, the Claim is deemed denied, thereby commencing the time for appeal of the denial. A denial of the Claim shall be final and binding unless within 30 days of the denial the other party invokes the procedure set forth in Article 17 for the final resolution of disputes.
- G. *Final and Binding Results*: If the parties reach a mutual agreement regarding a Claim, whether through approval of the Claim, direct negotiations, mediation, or otherwise; or if a Claim is approved in part and denied in part, or denied in full, and such actions become final and binding; then the results of the agreement or action on the Claim shall be incorporated in a Change Order to the extent they affect the Contract, including the Work, the Contract Times, or the Contract Price.

## **ARTICLE 13 – COST OF THE WORK; ALLOWANCES; UNIT PRICE WORK**

### 13.01 *Cost of the Work*

- A. *Purposes for Determination of Cost of the Work*: The term Cost of the Work means the sum of all costs necessary for the proper performance of the Work at issue, as further defined below. The provisions of this Paragraph 13.01 are used for two distinct purposes:
  1. To determine Cost of the Work when Cost of the Work is a component of the Contract Price, under cost-plus-fee, time-and-materials, or other cost-based terms; or
  2. To determine the value of a Change Order, Change Proposal, Claim, set-off, or other adjustment in Contract Price. When the value of any such adjustment is determined on the basis of Cost of the Work, Contractor is entitled only to those additional or incremental costs required because of the change in the Work or because of the event giving rise to the adjustment.
- B. *Costs Included*: Except as otherwise may be agreed to in writing by Owner, costs included in the Cost of the Work shall be in amounts no higher than those prevailing in the locality of the Project, shall not include any of the costs itemized in Paragraph 13.01.C, and shall include only the following items:
  1. Payroll costs for employees in the direct employ of Contractor in the performance of the Work under schedules of job classifications agreed upon by Owner and Contractor. Such employees shall include, without limitation, superintendents, foremen, and other personnel employed full time on the Work. Payroll costs for employees not employed full time on the Work shall be apportioned on the basis of their time spent on the Work. Payroll costs shall include, but not be limited to, salaries and wages plus the cost of fringe benefits, which shall include social security contributions, unemployment, excise, and payroll taxes, workers' compensation, health and retirement benefits, bonuses, sick leave, and vacation and holiday pay applicable

thereto. The expenses of performing Work outside of regular working hours, on Saturday, Sunday, or legal holidays, shall be included in the above to the extent authorized by Owner.

2. Cost of all materials and equipment furnished and incorporated in the Work, including costs of transportation and storage thereof, and Suppliers' field services required in connection therewith. All cash discounts shall accrue to Contractor unless Owner deposits funds with Contractor with which to make payments, in which case the cash discounts shall accrue to Owner. All trade discounts, rebates, and refunds and returns from sale of surplus materials and equipment shall accrue to Owner, and Contractor shall make provisions so that they may be obtained.
3. Payments made by Contractor to Subcontractors for Work performed by Subcontractors. If required by Owner, Contractor shall obtain competitive bids from subcontractors acceptable to Owner and Contractor and shall deliver such bids to Owner, who will then determine, with the advice of Engineer, which bids, if any, will be acceptable. If any subcontract provides that the Subcontractor is to be paid on the basis of Cost of the Work plus a fee, the Subcontractor's Cost of the Work and fee shall be determined in the same manner as Contractor's Cost of the Work and fee as provided in this Paragraph 13.01.
4. Costs of special consultants (including but not limited to engineers, architects, testing laboratories, surveyors, attorneys, and accountants) employed for services specifically related to the Work.
5. Supplemental costs including the following:
  - a. The proportion of necessary transportation, travel, and subsistence expenses of Contractor's employees incurred in discharge of duties connected with the Work.
  - b. Cost, including transportation and maintenance, of all materials, supplies, equipment, machinery, appliances, office, and temporary facilities at the Site, and hand tools not owned by the workers, which are consumed in the performance of the Work, and cost, less market value, of such items used but not consumed which remain the property of Contractor.
  - c. Rentals of all construction equipment and machinery, and the parts thereof, whether rented from Contractor or others in accordance with rental agreements approved by Owner with the advice of Engineer, and the costs of transportation, loading, unloading, assembly, dismantling, and removal thereof. All such costs shall be in accordance with the terms of said rental agreements. The rental of any such equipment, machinery, or parts shall cease when the use thereof is no longer necessary for the Work.
  - d. Sales, consumer, use, and other similar taxes related to the Work, and for which Contractor is liable, as imposed by Laws and Regulations.
  - e. Deposits lost for causes other than negligence of Contractor, any Subcontractor, or anyone directly or indirectly employed by any of them or for whose acts any of them may be liable, and royalty payments and fees for permits and licenses.
  - f. Losses and damages (and related expenses) caused by damage to the Work, not compensated by insurance or otherwise, sustained by Contractor in connection with the performance of the Work (except losses and damages within the deductible amounts of property insurance established in accordance with Paragraph 6.05), provided such losses and damages have resulted from causes

other than the negligence of Contractor, any Subcontractor, or anyone directly or indirectly employed by any of them or for whose acts any of them may be liable. Such losses shall include settlements made with the written consent and approval of Owner. No such losses, damages, and expenses shall be included in the Cost of the Work for the purpose of determining Contractor's fee.

- g. The cost of utilities, fuel, and sanitary facilities at the Site.
- h. Minor expenses such as communication service at the Site, express and courier services, and similar petty cash items in connection with the Work.
- i. The costs of premiums for all bonds and insurance that Contractor is required by the Contract Documents to purchase and maintain.

C. *Costs Excluded:* The term Cost of the Work shall not include any of the following items:

- 1. Payroll costs and other compensation of Contractor's officers, executives, principals (of partnerships and sole proprietorships), general managers, safety managers, engineers, architects, estimators, attorneys, auditors, accountants, purchasing and contracting agents, expeditors, timekeepers, clerks, and other personnel employed by Contractor, whether at the Site or in Contractor's principal or branch office for general administration of the Work and not specifically included in the agreed upon schedule of job classifications referred to in Paragraph 13.01.B.1 or specifically covered by Paragraph 13.01.B.4. The payroll costs and other compensation excluded here are to be considered administrative costs covered by the Contractor's fee.
- 2. Expenses of Contractor's principal and branch offices other than Contractor's office at the Site.
- 3. Any part of Contractor's capital expenses, including interest on Contractor's capital employed for the Work and charges against Contractor for delinquent payments.
- 4. Costs due to the negligence of Contractor, any Subcontractor, or anyone directly or indirectly employed by any of them or for whose acts any of them may be liable, including but not limited to, the correction of defective Work, disposal of materials or equipment wrongly supplied, and making good any damage to property.
- 5. Other overhead or general expense costs of any kind and the costs of any item not specifically and expressly included in Paragraph 13.01.B.

D. *Contractor's Fee:* When the Work as a whole is performed on the basis of cost-plus, Contractor's fee shall be determined as set forth in the Agreement. When the value of any Work covered by a Change Order, Change Proposal, Claim, set-off, or other adjustment in Contract Price is determined on the basis of Cost of the Work, Contractor's fee shall be determined as set forth in Paragraph 11.04.C.

E. *Documentation:* Whenever the Cost of the Work for any purpose is to be determined pursuant to this Article 13, Contractor will establish and maintain records thereof in accordance with generally accepted accounting practices and submit in a form acceptable to Engineer an itemized cost breakdown together with supporting data.

### 13.02 Allowances

- A. It is understood that Contractor has included in the Contract Price all allowances so named in the Contract Documents and shall cause the Work so covered to be performed for such sums and by such persons or entities as may be acceptable to Owner and Engineer.

- B. *Cash Allowances*: Contractor agrees that:
  - 1. the cash allowances include the cost to Contractor (less any applicable trade discounts) of materials and equipment required by the allowances to be delivered at the Site, and all applicable taxes; and
  - 2. Contractor's costs for unloading and handling on the Site, labor, installation, overhead, profit, and other expenses contemplated for the cash allowances have been included in the Contract Price and not in the allowances, and no demand for additional payment on account of any of the foregoing will be valid.
- C. *Contingency Allowance*: Contractor agrees that a contingency allowance, if any, is for the sole use of Owner to cover unanticipated costs.
- D. Prior to final payment, an appropriate Change Order will be issued as recommended by Engineer to reflect actual amounts due Contractor on account of Work covered by allowances, and the Contract Price shall be correspondingly adjusted.

### 13.03 *Unit Price Work*

- A. Where the Contract Documents provide that all or part of the Work is to be Unit Price Work, initially the Contract Price will be deemed to include for all Unit Price Work an amount equal to the sum of the unit price for each separately identified item of Unit Price Work times the estimated quantity of each item as indicated in the Agreement.
- B. The estimated quantities of items of Unit Price Work are not guaranteed and are solely for the purpose of comparison of Bids and determining an initial Contract Price. Payments to Contractor for Unit Price Work will be based on actual quantities.
- C. Each unit price will be deemed to include an amount considered by Contractor to be adequate to cover Contractor's overhead and profit for each separately identified item.
- D. Engineer will determine the actual quantities and classifications of Unit Price Work performed by Contractor. Engineer will review with Contractor the Engineer's preliminary determinations on such matters before rendering a written decision thereon (by recommendation of an Application for Payment or otherwise). Engineer's written decision thereon will be final and binding (except as modified by Engineer to reflect changed factual conditions or more accurate data) upon Owner and Contractor, subject to the provisions of the following paragraph.
- E. Within 30 days of Engineer's written decision under the preceding paragraph, Contractor may submit a Change Proposal, or Owner may file a Claim, seeking an adjustment in the Contract Price if:
  - 1. the quantity of any item of Unit Price Work performed by Contractor differs materially and significantly from the estimated quantity of such item indicated in the Agreement;
  - 2. there is no corresponding adjustment with respect to any other item of Work; and
  - 3. Contractor believes that it is entitled to an increase in Contract Price as a result of having incurred additional expense or Owner believes that Owner is entitled to a decrease in Contract Price, and the parties are unable to agree as to the amount of any such increase or decrease.

## ARTICLE 14 – TESTS AND INSPECTIONS; CORRECTION, REMOVAL OR ACCEPTANCE OF DEFECTIVE WORK

### 14.01 *Access to Work*

- A. Owner, Engineer, their consultants and other representatives and personnel of Owner, independent testing laboratories, and authorities having jurisdiction will have access to the Site and the Work at reasonable times for their observation, inspection, and testing. Contractor shall provide them proper and safe conditions for such access and advise them of Contractor's safety procedures and programs so that they may comply therewith as applicable.

### 14.02 *Tests, Inspections, and Approvals*

- A. Contractor shall give Engineer timely notice of readiness of the Work (or specific parts thereof) for all required inspections and tests, and shall cooperate with inspection and testing personnel to facilitate required inspections and tests.
- B. Owner shall retain and pay for the services of an independent inspector, testing laboratory, or other qualified individual or entity to perform all inspections and tests expressly required by the Contract Documents to be furnished and paid for by Owner, except that costs incurred in connection with tests or inspections of covered Work shall be governed by the provisions of Paragraph 14.05.
- C. If Laws or Regulations of any public body having jurisdiction require any Work (or part thereof) specifically to be inspected, tested, or approved by an employee or other representative of such public body, Contractor shall assume full responsibility for arranging and obtaining such inspections, tests, or approvals, pay all costs in connection therewith, and furnish Engineer the required certificates of inspection or approval.
- D. Contractor shall be responsible for arranging, obtaining, and paying for all inspections and tests required:
  - 1. by the Contract Documents, unless the Contract Documents expressly allocate responsibility for a specific inspection or test to Owner;
  - 2. to attain Owner's and Engineer's acceptance of materials or equipment to be incorporated in the Work;
  - 3. by manufacturers of equipment furnished under the Contract Documents;
  - 4. for testing, adjusting, and balancing of mechanical, electrical, and other equipment to be incorporated into the Work; and
  - 5. for acceptance of materials, mix designs, or equipment submitted for approval prior to Contractor's purchase thereof for incorporation in the Work.

Such inspections and tests shall be performed by independent inspectors, testing laboratories, or other qualified individuals or entities acceptable to Owner and Engineer.

- E. If the Contract Documents require the Work (or part thereof) to be approved by Owner, Engineer, or another designated individual or entity, then Contractor shall assume full responsibility for arranging and obtaining such approvals.
- F. If any Work (or the work of others) that is to be inspected, tested, or approved is covered by Contractor without written concurrence of Engineer, Contractor shall, if requested by Engineer, uncover such Work for observation. Such uncovering shall be at Contractor's expense unless Contractor had given Engineer timely notice of Contractor's intention to

cover the same and Engineer had not acted with reasonable promptness in response to such notice.

#### 14.03 *Defective Work*

- A. *Contractor's Obligation:* It is Contractor's obligation to assure that the Work is not defective.
- B. *Engineer's Authority:* Engineer has the authority to determine whether Work is defective, and to reject defective Work.
- C. *Notice of Defects:* Prompt notice of all defective Work of which Owner or Engineer has actual knowledge will be given to Contractor.
- D. *Correction, or Removal and Replacement:* Promptly after receipt of written notice of defective Work, Contractor shall correct all such defective Work, whether or not fabricated, installed, or completed, or, if Engineer has rejected the defective Work, remove it from the Project and replace it with Work that is not defective.
- E. *Preservation of Warranties:* When correcting defective Work, Contractor shall take no action that would void or otherwise impair Owner's special warranty and guarantee, if any, on said Work.
- F. *Costs and Damages:* In addition to its correction, removal, and replacement obligations with respect to defective Work, Contractor shall pay all claims, costs, losses, and damages arising out of or relating to defective Work, including but not limited to the cost of the inspection, testing, correction, removal, replacement, or reconstruction of such defective Work, fines levied against Owner by governmental authorities because the Work is defective, and the costs of repair or replacement of work of others resulting from defective Work. Prior to final payment, if Owner and Contractor are unable to agree as to the measure of such claims, costs, losses, and damages resulting from defective Work, then Owner may impose a reasonable set-off against payments due under Article 15.

#### 14.04 *Acceptance of Defective Work*

- A. If, instead of requiring correction or removal and replacement of defective Work, Owner prefers to accept it, Owner may do so (subject, if such acceptance occurs prior to final payment, to Engineer's confirmation that such acceptance is in general accord with the design intent and applicable engineering principles, and will not endanger public safety). Contractor shall pay all claims, costs, losses, and damages attributable to Owner's evaluation of and determination to accept such defective Work (such costs to be approved by Engineer as to reasonableness), and for the diminished value of the Work to the extent not otherwise paid by Contractor. If any such acceptance occurs prior to final payment, the necessary revisions in the Contract Documents with respect to the Work shall be incorporated in a Change Order. If the parties are unable to agree as to the decrease in the Contract Price, reflecting the diminished value of Work so accepted, then Owner may impose a reasonable set-off against payments due under Article 15. If the acceptance of defective Work occurs after final payment, Contractor shall pay an appropriate amount to Owner.

#### 14.05 *Uncovering Work*

- A. Engineer has the authority to require special inspection or testing of the Work, whether or not the Work is fabricated, installed, or completed.



- B. If any Work is covered contrary to the written request of Engineer, then Contractor shall, if requested by Engineer, uncover such Work for Engineer's observation, and then replace the covering, all at Contractor's expense.
- C. If Engineer considers it necessary or advisable that covered Work be observed by Engineer or inspected or tested by others, then Contractor, at Engineer's request, shall uncover, expose, or otherwise make available for observation, inspection, or testing as Engineer may require, that portion of the Work in question, and provide all necessary labor, material, and equipment.
  - 1. If it is found that the uncovered Work is defective, Contractor shall be responsible for all claims, costs, losses, and damages arising out of or relating to such uncovering, exposure, observation, inspection, and testing, and of satisfactory replacement or reconstruction (including but not limited to all costs of repair or replacement of work of others); and pending Contractor's full discharge of this responsibility the Owner shall be entitled to impose a reasonable set-off against payments due under Article 15.
  - 2. If the uncovered Work is not found to be defective, Contractor shall be allowed an increase in the Contract Price or an extension of the Contract Times, or both, directly attributable to such uncovering, exposure, observation, inspection, testing, replacement, and reconstruction. If the parties are unable to agree as to the amount or extent thereof, then Contractor may submit a Change Proposal within 30 days of the determination that the Work is not defective.

#### 14.06 *Owner May Stop the Work*

- A. If the Work is defective, or Contractor fails to supply sufficient skilled workers or suitable materials or equipment, or fails to perform the Work in such a way that the completed Work will conform to the Contract Documents, then Owner may order Contractor to stop the Work, or any portion thereof, until the cause for such order has been eliminated; however, this right of Owner to stop the Work shall not give rise to any duty on the part of Owner to exercise this right for the benefit of Contractor, any Subcontractor, any Supplier, any other individual or entity, or any surety for, or employee or agent of any of them.

#### 14.07 *Owner May Correct Defective Work*

- A. If Contractor fails within a reasonable time after written notice from Engineer to correct defective Work, or to remove and replace rejected Work as required by Engineer, or if Contractor fails to perform the Work in accordance with the Contract Documents, or if Contractor fails to comply with any other provision of the Contract Documents, then Owner may, after seven days written notice to Contractor, correct or remedy any such deficiency.
- B. In exercising the rights and remedies under this Paragraph 14.07, Owner shall proceed expeditiously. In connection with such corrective or remedial action, Owner may exclude Contractor from all or part of the Site, take possession of all or part of the Work and suspend Contractor's services related thereto, and incorporate in the Work all materials and equipment stored at the Site or for which Owner has paid Contractor but which are stored elsewhere. Contractor shall allow Owner, Owner's representatives, agents and employees, Owner's other contractors, and Engineer and Engineer's consultants access to the Site to enable Owner to exercise the rights and remedies under this paragraph.
- C. All claims, costs, losses, and damages incurred or sustained by Owner in exercising the rights and remedies under this Paragraph 14.07 will be charged against Contractor as set-offs against payments due under Article 15. Such claims, costs, losses and damages will

include but not be limited to all costs of repair, or replacement of work of others destroyed or damaged by correction, removal, or replacement of Contractor's defective Work.

- D. Contractor shall not be allowed an extension of the Contract Times because of any delay in the performance of the Work attributable to the exercise by Owner of Owner's rights and remedies under this Paragraph 14.07.

## **ARTICLE 15 – PAYMENTS TO CONTRACTOR; SET-OFFS; COMPLETION; CORRECTION PERIOD**

### **15.01 Progress Payments**

- A. *Basis for Progress Payments:* The Schedule of Values established as provided in Article 2 will serve as the basis for progress payments and will be incorporated into a form of Application for Payment acceptable to Engineer. Progress payments on account of Unit Price Work will be based on the number of units completed during the pay period, as determined under the provisions of Paragraph 13.03. Progress payments for cost-based Work will be based on Cost of the Work completed by Contractor during the pay period.
- B. *Applications for Payments:*
1. At least 20 days before the date established in the Agreement for each progress payment (but not more often than once a month), Contractor shall submit to Engineer for review an Application for Payment filled out and signed by Contractor covering the Work completed as of the date of the Application and accompanied by such supporting documentation as is required by the Contract Documents. If payment is requested on the basis of materials and equipment not incorporated in the Work but delivered and suitably stored at the Site or at another location agreed to in writing, the Application for Payment shall also be accompanied by a bill of sale, invoice, or other documentation warranting that Owner has received the materials and equipment free and clear of all Liens, and evidence that the materials and equipment are covered by appropriate property insurance, a warehouse bond, or other arrangements to protect Owner's interest therein, all of which must be satisfactory to Owner.
  2. Beginning with the second Application for Payment, each Application shall include an affidavit of Contractor stating that all previous progress payments received on account of the Work have been applied on account to discharge Contractor's legitimate obligations associated with prior Applications for Payment.
  3. The amount of retainage with respect to progress payments will be as stipulated in the Agreement.
- C. *Review of Applications:*
1. Engineer will, within 10 days after receipt of each Application for Payment, including each resubmittal, either indicate in writing a recommendation of payment and present the Application to Owner, or return the Application to Contractor indicating in writing Engineer's reasons for refusing to recommend payment. In the latter case, Contractor may make the necessary corrections and resubmit the Application.
  2. Engineer's recommendation of any payment requested in an Application for Payment will constitute a representation by Engineer to Owner, based on Engineer's observations of the executed Work as an experienced and qualified design professional, and on Engineer's review of the Application for Payment and the accompanying data and schedules, that to the best of Engineer's knowledge, information and belief:

- a. the Work has progressed to the point indicated;
  - b. the quality of the Work is generally in accordance with the Contract Documents (subject to an evaluation of the Work as a functioning whole prior to or upon Substantial Completion, the results of any subsequent tests called for in the Contract Documents, a final determination of quantities and classifications for Unit Price Work under Paragraph 13.03, and any other qualifications stated in the recommendation); and
  - c. the conditions precedent to Contractor's being entitled to such payment appear to have been fulfilled in so far as it is Engineer's responsibility to observe the Work.
3. By recommending any such payment Engineer will not thereby be deemed to have represented that:
- a. inspections made to check the quality or the quantity of the Work as it has been performed have been exhaustive, extended to every aspect of the Work in progress, or involved detailed inspections of the Work beyond the responsibilities specifically assigned to Engineer in the Contract; or
  - b. there may not be other matters or issues between the parties that might entitle Contractor to be paid additionally by Owner or entitle Owner to withhold payment to Contractor.
4. Neither Engineer's review of Contractor's Work for the purposes of recommending payments nor Engineer's recommendation of any payment, including final payment, will impose responsibility on Engineer:
- a. to supervise, direct, or control the Work, or
  - b. for the means, methods, techniques, sequences, or procedures of construction, or the safety precautions and programs incident thereto, or
  - c. for Contractor's failure to comply with Laws and Regulations applicable to Contractor's performance of the Work, or
  - d. to make any examination to ascertain how or for what purposes Contractor has used the money paid on account of the Contract Price, or
  - e. to determine that title to any of the Work, materials, or equipment has passed to Owner free and clear of any Liens.
5. Engineer may refuse to recommend the whole or any part of any payment if, in Engineer's opinion, it would be incorrect to make the representations to Owner stated in Paragraph 15.01.C.2.
6. Engineer will recommend reductions in payment (set-offs) necessary in Engineer's opinion to protect Owner from loss because:
- a. the Work is defective, requiring correction or replacement;
  - b. the Contract Price has been reduced by Change Orders;
  - c. Owner has been required to correct defective Work in accordance with Paragraph 14.07, or has accepted defective Work pursuant to Paragraph 14.04;
  - d. Owner has been required to remove or remediate a Hazardous Environmental Condition for which Contractor is responsible; or

- e. Engineer has actual knowledge of the occurrence of any of the events that would constitute a default by Contractor and therefore justify termination for cause under the Contract Documents.

D. *Payment Becomes Due:*

- 1. Ten days after presentation of the Application for Payment to Owner with Engineer's recommendation, the amount recommended (subject to any Owner set-offs) will become due, and when due will be paid by Owner to Contractor.

E. *Reductions in Payment by Owner:*

- 1. In addition to any reductions in payment (set-offs) recommended by Engineer, Owner is entitled to impose a set-off against payment based on any of the following:
  - a. claims have been made against Owner on account of Contractor's conduct in the performance or furnishing of the Work, or Owner has incurred costs, losses, or damages on account of Contractor's conduct in the performance or furnishing of the Work, including but not limited to claims, costs, losses, or damages from workplace injuries, adjacent property damage, non-compliance with Laws and Regulations, and patent infringement;
  - b. Contractor has failed to take reasonable and customary measures to avoid damage, delay, disruption, and interference with other work at or adjacent to the Site;
  - c. Contractor has failed to provide and maintain required bonds or insurance;
  - d. Owner has been required to remove or remediate a Hazardous Environmental Condition for which Contractor is responsible;
  - e. Owner has incurred extra charges or engineering costs related to submittal reviews, evaluations of proposed substitutes, tests and inspections, or return visits to manufacturing or assembly facilities;
  - f. the Work is defective, requiring correction or replacement;
  - g. Owner has been required to correct defective Work in accordance with Paragraph 14.07, or has accepted defective Work pursuant to Paragraph 14.04;
  - h. the Contract Price has been reduced by Change Orders;
  - i. an event that would constitute a default by Contractor and therefore justify a termination for cause has occurred;
  - j. liquidated damages have accrued as a result of Contractor's failure to achieve Milestones, Substantial Completion, or final completion of the Work;
  - k. Liens have been filed in connection with the Work, except where Contractor has delivered a specific bond satisfactory to Owner to secure the satisfaction and discharge of such Liens;
  - l. there are other items entitling Owner to a set off against the amount recommended.
- 2. If Owner imposes any set-off against payment, whether based on its own knowledge or on the written recommendations of Engineer, Owner will give Contractor immediate written notice (with a copy to Engineer) stating the reasons for such action and the specific amount of the reduction, and promptly pay Contractor any amount

remaining after deduction of the amount so withheld. Owner shall promptly pay Contractor the amount so withheld, or any adjustment thereto agreed to by Owner and Contractor, if Contractor remedies the reasons for such action. The reduction imposed shall be binding on Contractor unless it duly submits a Change Proposal contesting the reduction.

3. Upon a subsequent determination that Owner's refusal of payment was not justified, the amount wrongfully withheld shall be treated as an amount due as determined by Paragraph 15.01.C.1 and subject to interest as provided in the Agreement.

#### 15.02 *Contractor's Warranty of Title*

- A. Contractor warrants and guarantees that title to all Work, materials, and equipment furnished under the Contract will pass to Owner free and clear of (1) all Liens and other title defects, and (2) all patent, licensing, copyright, or royalty obligations, no later than seven days after the time of payment by Owner.

#### 15.03 *Substantial Completion*

- A. When Contractor considers the entire Work ready for its intended use Contractor shall notify Owner and Engineer in writing that the entire Work is substantially complete and request that Engineer issue a certificate of Substantial Completion. Contractor shall at the same time submit to Owner and Engineer an initial draft of punch list items to be completed or corrected before final payment.
- B. Promptly after Contractor's notification, Owner, Contractor, and Engineer shall make an inspection of the Work to determine the status of completion. If Engineer does not consider the Work substantially complete, Engineer will notify Contractor in writing giving the reasons therefor.
- C. If Engineer considers the Work substantially complete, Engineer will deliver to Owner a preliminary certificate of Substantial Completion which shall fix the date of Substantial Completion. Engineer shall attach to the certificate a punch list of items to be completed or corrected before final payment. Owner shall have seven days after receipt of the preliminary certificate during which to make written objection to Engineer as to any provisions of the certificate or attached punch list. If, after considering the objections to the provisions of the preliminary certificate, Engineer concludes that the Work is not substantially complete, Engineer will, within 14 days after submission of the preliminary certificate to Owner, notify Contractor in writing that the Work is not substantially complete, stating the reasons therefor. If Owner does not object to the provisions of the certificate, or if despite consideration of Owner's objections Engineer concludes that the Work is substantially complete, then Engineer will, within said 14 days, execute and deliver to Owner and Contractor a final certificate of Substantial Completion (with a revised punch list of items to be completed or corrected) reflecting such changes from the preliminary certificate as Engineer believes justified after consideration of any objections from Owner.
- D. At the time of receipt of the preliminary certificate of Substantial Completion, Owner and Contractor will confer regarding Owner's use or occupancy of the Work following Substantial Completion, review the builder's risk insurance policy with respect to the end of the builder's risk coverage, and confirm the transition to coverage of the Work under a permanent property insurance policy held by Owner. Unless Owner and Contractor agree otherwise in writing, Owner shall bear responsibility for security, operation, protection of the Work, property insurance, maintenance, heat, and utilities upon Owner's use or occupancy of the Work.

- E. After Substantial Completion the Contractor shall promptly begin work on the punch list of items to be completed or corrected prior to final payment. In appropriate cases Contractor may submit monthly Applications for Payment for completed punch list items, following the progress payment procedures set forth above.
- F. Owner shall have the right to exclude Contractor from the Site after the date of Substantial Completion subject to allowing Contractor reasonable access to remove its property and complete or correct items on the punch list.

#### 15.04 *Partial Use or Occupancy*

- A. Prior to Substantial Completion of all the Work, Owner may use or occupy any substantially completed part of the Work which has specifically been identified in the Contract Documents, or which Owner, Engineer, and Contractor agree constitutes a separately functioning and usable part of the Work that can be used by Owner for its intended purpose without significant interference with Contractor's performance of the remainder of the Work, subject to the following conditions:
  - 1. At any time Owner may request in writing that Contractor permit Owner to use or occupy any such part of the Work that Owner believes to be substantially complete. If and when Contractor agrees that such part of the Work is substantially complete, Contractor, Owner, and Engineer will follow the procedures of Paragraph 15.03.A through E for that part of the Work.
  - 2. At any time Contractor may notify Owner and Engineer in writing that Contractor considers any such part of the Work substantially complete and request Engineer to issue a certificate of Substantial Completion for that part of the Work.
  - 3. Within a reasonable time after either such request, Owner, Contractor, and Engineer shall make an inspection of that part of the Work to determine its status of completion. If Engineer does not consider that part of the Work to be substantially complete, Engineer will notify Owner and Contractor in writing giving the reasons therefor. If Engineer considers that part of the Work to be substantially complete, the provisions of Paragraph 15.03 will apply with respect to certification of Substantial Completion of that part of the Work and the division of responsibility in respect thereof and access thereto.
  - 4. No use or occupancy or separate operation of part of the Work may occur prior to compliance with the requirements of Paragraph 6.05 regarding builder's risk or other property insurance.

#### 15.05 *Final Inspection*

- A. Upon written notice from Contractor that the entire Work or an agreed portion thereof is complete, Engineer will promptly make a final inspection with Owner and Contractor and will notify Contractor in writing of all particulars in which this inspection reveals that the Work, or agreed portion thereof, is incomplete or defective. Contractor shall immediately take such measures as are necessary to complete such Work or remedy such deficiencies.

#### 15.06 *Final Payment*

- A. *Application for Payment:*
  - 1. After Contractor has, in the opinion of Engineer, satisfactorily completed all corrections identified during the final inspection and has delivered, in accordance with the Contract Documents, all maintenance and operating instructions, schedules, guarantees, bonds, certificates or other evidence of insurance, certificates of

inspection, annotated record documents (as provided in Paragraph 7.11), and other documents, Contractor may make application for final payment.

2. The final Application for Payment shall be accompanied (except as previously delivered) by:
  - a. all documentation called for in the Contract Documents;
  - b. consent of the surety, if any, to final payment;
  - c. satisfactory evidence that all title issues have been resolved such that title to all Work, materials, and equipment has passed to Owner free and clear of any Liens or other title defects, or will so pass upon final payment.
  - d. a list of all disputes that Contractor believes are unsettled; and
  - e. complete and legally effective releases or waivers (satisfactory to Owner) of all Lien rights arising out of the Work, and of Liens filed in connection with the Work.
3. In lieu of the releases or waivers of Liens specified in Paragraph 15.06.A.2 and as approved by Owner, Contractor may furnish receipts or releases in full and an affidavit of Contractor that: (a) the releases and receipts include all labor, services, material, and equipment for which a Lien could be filed; and (b) all payrolls, material and equipment bills, and other indebtedness connected with the Work for which Owner might in any way be responsible, or which might in any way result in liens or other burdens on Owner's property, have been paid or otherwise satisfied. If any Subcontractor or Supplier fails to furnish such a release or receipt in full, Contractor may furnish a bond or other collateral satisfactory to Owner to indemnify Owner against any Lien, or Owner at its option may issue joint checks payable to Contractor and specified Subcontractors and Suppliers.

**B. *Engineer's Review of Application and Acceptance:***

1. If, on the basis of Engineer's observation of the Work during construction and final inspection, and Engineer's review of the final Application for Payment and accompanying documentation as required by the Contract Documents, Engineer is satisfied that the Work has been completed and Contractor's other obligations under the Contract have been fulfilled, Engineer will, within ten days after receipt of the final Application for Payment, indicate in writing Engineer's recommendation of final payment and present the Application for Payment to Owner for payment. Such recommendation shall account for any set-offs against payment that are necessary in Engineer's opinion to protect Owner from loss for the reasons stated above with respect to progress payments. At the same time Engineer will also give written notice to Owner and Contractor that the Work is acceptable, subject to the provisions of Paragraph 15.07. Otherwise, Engineer will return the Application for Payment to Contractor, indicating in writing the reasons for refusing to recommend final payment, in which case Contractor shall make the necessary corrections and resubmit the Application for Payment.

**C. *Completion of Work:*** The Work is complete (subject to surviving obligations) when it is ready for final payment as established by the Engineer's written recommendation of final payment.

**D. *Payment Becomes Due:*** Thirty days after the presentation to Owner of the final Application for Payment and accompanying documentation, the amount recommended by Engineer (less any further sum Owner is entitled to set off against Engineer's recommendation,

including but not limited to set-offs for liquidated damages and set-offs allowed under the provisions above with respect to progress payments) will become due and shall be paid by Owner to Contractor.

#### 15.07 *Waiver of Claims*

- A. The making of final payment will not constitute a waiver by Owner of claims or rights against Contractor. Owner expressly reserves claims and rights arising from unsettled Liens, from defective Work appearing after final inspection pursuant to Paragraph 15.05, from Contractor's failure to comply with the Contract Documents or the terms of any special guarantees specified therein, from outstanding Claims by Owner, or from Contractor's continuing obligations under the Contract Documents.
- B. The acceptance of final payment by Contractor will constitute a waiver by Contractor of all claims and rights against Owner other than those pending matters that have been duly submitted or appealed under the provisions of Article 17.

#### 15.08 *Correction Period*

- A. If within one year after the date of Substantial Completion (or such longer period of time as may be prescribed by the terms of any applicable special guarantee required by the Contract Documents, or by any specific provision of the Contract Documents), any Work is found to be defective, or if the repair of any damages to the Site, adjacent areas that Contractor has arranged to use through construction easements or otherwise, and other adjacent areas used by Contractor as permitted by Laws and Regulations, is found to be defective, then Contractor shall promptly, without cost to Owner and in accordance with Owner's written instructions:
  - 1. correct the defective repairs to the Site or such other adjacent areas;
  - 2. correct such defective Work;
  - 3. if the defective Work has been rejected by Owner, remove it from the Project and replace it with Work that is not defective, and
  - 4. satisfactorily correct or repair or remove and replace any damage to other Work, to the work of others, or to other land or areas resulting therefrom.
- B. If Contractor does not promptly comply with the terms of Owner's written instructions, or in an emergency where delay would cause serious risk of loss or damage, Owner may have the defective Work corrected or repaired or may have the rejected Work removed and replaced. Contractor shall pay all claims, costs, losses, and damages (including but not limited to all fees and charges of engineers, architects, attorneys, and other professionals and all court or arbitration or other dispute resolution costs) arising out of or relating to such correction or repair or such removal and replacement (including but not limited to all costs of repair or replacement of work of others).
- C. In special circumstances where a particular item of equipment is placed in continuous service before Substantial Completion of all the Work, the correction period for that item may start to run from an earlier date if so provided in the Specifications.
- D. Where defective Work (and damage to other Work resulting therefrom) has been corrected or removed and replaced under this paragraph, the correction period hereunder with respect to such Work will be extended for an additional period of one year after such correction or removal and replacement has been satisfactorily completed.



- E. Contractor's obligations under this paragraph are in addition to all other obligations and warranties. The provisions of this paragraph shall not be construed as a substitute for, or a waiver of, the provisions of any applicable statute of limitation or repose.

## **ARTICLE 16 – SUSPENSION OF WORK AND TERMINATION**

### **16.01 *Owner May Suspend Work***

- A. At any time and without cause, Owner may suspend the Work or any portion thereof for a period of not more than 90 consecutive days by written notice to Contractor and Engineer. Such notice will fix the date on which Work will be resumed. Contractor shall resume the Work on the date so fixed. Contractor shall be entitled to an adjustment in the Contract Price or an extension of the Contract Times, or both, directly attributable to any such suspension. Any Change Proposal seeking such adjustments shall be submitted no later than 30 days after the date fixed for resumption of Work.

### **16.02 *Owner May Terminate for Cause***

- A. The occurrence of any one or more of the following events will constitute a default by Contractor and justify termination for cause:
  - 1. Contractor's persistent failure to perform the Work in accordance with the Contract Documents (including, but not limited to, failure to supply sufficient skilled workers or suitable materials or equipment or failure to adhere to the Progress Schedule);
  - 2. Failure of Contractor to perform or otherwise to comply with a material term of the Contract Documents;
  - 3. Contractor's disregard of Laws or Regulations of any public body having jurisdiction; or
  - 4. Contractor's repeated disregard of the authority of Owner or Engineer.
- B. If one or more of the events identified in Paragraph 16.02.A occurs, then after giving Contractor (and any surety) ten days written notice that Owner is considering a declaration that Contractor is in default and termination of the contract, Owner may proceed to:
  - 1. declare Contractor to be in default, and give Contractor (and any surety) notice that the Contract is terminated; and
  - 2. enforce the rights available to Owner under any applicable performance bond.
- C. Subject to the terms and operation of any applicable performance bond, if Owner has terminated the Contract for cause, Owner may exclude Contractor from the Site, take possession of the Work, incorporate in the Work all materials and equipment stored at the Site or for which Owner has paid Contractor but which are stored elsewhere, and complete the Work as Owner may deem expedient.
- D. Owner may not proceed with termination of the Contract under Paragraph 16.02.B if Contractor within seven days of receipt of notice of intent to terminate begins to correct its failure to perform and proceeds diligently to cure such failure.
- E. If Owner proceeds as provided in Paragraph 16.02.B, Contractor shall not be entitled to receive any further payment until the Work is completed. If the unpaid balance of the Contract Price exceeds the cost to complete the Work, including all related claims, costs, losses, and damages (including but not limited to all fees and charges of engineers, architects, attorneys, and other professionals) sustained by Owner, such excess will be paid to Contractor. If the cost to complete the Work including such related claims, costs, losses,

and damages exceeds such unpaid balance, Contractor shall pay the difference to Owner. Such claims, costs, losses, and damages incurred by Owner will be reviewed by Engineer as to their reasonableness and, when so approved by Engineer, incorporated in a Change Order. When exercising any rights or remedies under this paragraph, Owner shall not be required to obtain the lowest price for the Work performed.

- F. Where Contractor's services have been so terminated by Owner, the termination will not affect any rights or remedies of Owner against Contractor then existing or which may thereafter accrue, or any rights or remedies of Owner against Contractor or any surety under any payment bond or performance bond. Any retention or payment of money due Contractor by Owner will not release Contractor from liability.
- G. If and to the extent that Contractor has provided a performance bond under the provisions of Paragraph 6.01.A, the provisions of that bond shall govern over any inconsistent provisions of Paragraphs 16.02.B and 16.02.D.

#### 16.03 *Owner May Terminate For Convenience*

- A. Upon seven days written notice to Contractor and Engineer, Owner may, without cause and without prejudice to any other right or remedy of Owner, terminate the Contract. In such case, Contractor shall be paid for (without duplication of any items):
  - 1. completed and acceptable Work executed in accordance with the Contract Documents prior to the effective date of termination, including fair and reasonable sums for overhead and profit on such Work;
  - 2. expenses sustained prior to the effective date of termination in performing services and furnishing labor, materials, or equipment as required by the Contract Documents in connection with uncompleted Work, plus fair and reasonable sums for overhead and profit on such expenses; and
  - 3. other reasonable expenses directly attributable to termination, including costs incurred to prepare a termination for convenience cost proposal.
- B. Contractor shall not be paid on account of loss of anticipated overhead, profits, or revenue, or other economic loss arising out of or resulting from such termination.

#### 16.04 *Contractor May Stop Work or Terminate*

- A. If, through no act or fault of Contractor, (1) the Work is suspended for more than 90 consecutive days by Owner or under an order of court or other public authority, or (2) Engineer fails to act on any Application for Payment within 30 days after it is submitted, or (3) Owner fails for 30 days to pay Contractor any sum finally determined to be due, then Contractor may, upon seven days written notice to Owner and Engineer, and provided Owner or Engineer do not remedy such suspension or failure within that time, terminate the contract and recover from Owner payment on the same terms as provided in Paragraph 16.03.
- B. In lieu of terminating the Contract and without prejudice to any other right or remedy, if Engineer has failed to act on an Application for Payment within 30 days after it is submitted, or Owner has failed for 30 days to pay Contractor any sum finally determined to be due, Contractor may, seven days after written notice to Owner and Engineer, stop the Work until payment is made of all such amounts due Contractor, including interest thereon. The provisions of this paragraph are not intended to preclude Contractor from submitting a Change Proposal for an adjustment in Contract Price or Contract Times or otherwise for

expenses or damage directly attributable to Contractor's stopping the Work as permitted by this paragraph.

## **ARTICLE 17 – FINAL RESOLUTION OF DISPUTES**

### **17.01 *Methods and Procedures***

- A. *Disputes Subject to Final Resolution:* The following disputed matters are subject to final resolution under the provisions of this Article:
  - 1. A timely appeal of an approval in part and denial in part of a Claim, or of a denial in full; and
  - 2. Disputes between Owner and Contractor concerning the Work or obligations under the Contract Documents, and arising after final payment has been made.
- B. *Final Resolution of Disputes:* For any dispute subject to resolution under this Article, Owner or Contractor may:
  - 1. elect in writing to invoke the dispute resolution process provided for in the Supplementary Conditions; or
  - 2. agree with the other party to submit the dispute to another dispute resolution process; or
  - 3. if no dispute resolution process is provided for in the Supplementary Conditions or mutually agreed to, give written notice to the other party of the intent to submit the dispute to a court of competent jurisdiction.

## **ARTICLE 18 – MISCELLANEOUS**

### **18.01 *Giving Notice***

- A. Whenever any provision of the Contract Documents requires the giving of written notice, it will be deemed to have been validly given if:
  - 1. delivered in person, by a commercial courier service or otherwise, to the individual or to a member of the firm or to an officer of the corporation for which it is intended; or
  - 2. delivered at or sent by registered or certified mail, postage prepaid, to the last business address known to the sender of the notice.

### **18.02 *Computation of Times***

- A. When any period of time is referred to in the Contract by days, it will be computed to exclude the first and include the last day of such period. If the last day of any such period falls on a Saturday or Sunday or on a day made a legal holiday by the law of the applicable jurisdiction, such day will be omitted from the computation.

### **18.03 *Cumulative Remedies***

- A. The duties and obligations imposed by these General Conditions and the rights and remedies available hereunder to the parties hereto are in addition to, and are not to be construed in any way as a limitation of, any rights and remedies available to any or all of them which are otherwise imposed or available by Laws or Regulations, by special warranty or guarantee, or by other provisions of the Contract. The provisions of this paragraph will be as effective as if repeated specifically in the Contract Documents in connection with each particular duty, obligation, right, and remedy to which they apply.

18.04 *Limitation of Damages*

- A. With respect to any and all Change Proposals, Claims, disputes subject to final resolution, and other matters at issue, neither Owner nor Engineer, nor any of their officers, directors, members, partners, employees, agents, consultants, or subcontractors, shall be liable to Contractor for any claims, costs, losses, or damages sustained by Contractor on or in connection with any other project or anticipated project.

18.05 *No Waiver*

- A. A party's non-enforcement of any provision shall not constitute a waiver of that provision, nor shall it affect the enforceability of that provision or of the remainder of this Contract.

18.06 *Survival of Obligations*

- A. All representations, indemnifications, warranties, and guarantees made in, required by, or given in accordance with the Contract, as well as all continuing obligations indicated in the Contract, will survive final payment, completion, and acceptance of the Work or termination or completion of the Contract or termination of the services of Contractor.

18.07 *Controlling Law*

- A. This Contract is to be governed by the law of the state in which the Project is located.

18.08 *Headings*

- A. Article and paragraph headings are inserted for convenience only and do not constitute parts of these General Conditions.

00 73 00

SUPPLEMENTARY CONDITIONS

Supplementary Conditions - Table of Contents

SC 0 INTRODUCTION ..... 3

SC 1 – DEFINITIONS AND TERMINOLOGY ..... 3

SC 1.01 DEFINED TERMS ..... 3

SC 2 – PRELIMINARY MATTERS ..... 3

SC 2.01 DELIVERY OF BONDS AND EVIDENCE OF INSURANCE..... 3

SC 2.02.A COPIES OF DOCUMENTS ..... 3

SC 2.03 BEFORE STARTING CONSTRUCTION..... 3

SC 2.05 INITIAL ACCEPTANCE OF SCHEDULES..... 4

SC 3 - DOCUMENTS ..... 4

SC 3.02 REFERENCE STANDARDS ..... 4

SC 4 – COMMENCEMENT AND PROGRESS OF WORK..... 6

SC 4.03 REFERENCE POINTS ..... 6

SC 4.04 PROGRESS SCHEDULE..... 6

SC 5 –AVAILABILITY OF LANDS, ETC. .... 6

SC 5.03 SUBSURFACE AND PHYSICAL CONDITIONS ..... 6

SC 5.04 DIFFERING SUBSURFACE OR PHYSICAL CONDITIONS ..... 6

SC 5.06I HAZARDOUS ENVIRONMENTAL CONDITION AT SITE ..... 7

SC 6 – BONDS AND INSURANCE ..... 7

SC 6.01B PERFORMANCE, PAYMENT, AND OTHER BONDS ..... 7

SC 6.04 OWNER’S LIABILITY INSURANCE ..... 7

SC 6.05 PROPERTY INSURANCE..... 8

SC 6.06 WAIVER OF RIGHTS ..... 8

SC 7 – CONTRACTORS RESPONSIBILITY..... 8

SC 7.02 LABOR; WORKING HOURS..... 8

SC 7.06 CONCERNING SUBCONTRACTORS, SUPPLIERS, AND OTHERS ..... 8

SC 7.09 TAXES .....	9
SC 7.10 LAWS AND REGULATIONS .....	9
SC 7.18 INDEMNIFICATION .....	9
SC 8 – OTHER WORK ON SITE.....	10
SC 9 – OWNERS RESPONSIBILITY .....	10
SC 10 – ENGINEERS STATUS DURING CONSTRUCTION .....	10
SC 10.02 VISITS TO SITE.....	10
SC 10.08 LIMITATION ON ENGINEER’S AUTHORITY AND RESPONSIBILITIES .....	14
SC 12 – CLAIMS .....	14
SC 12.01 CLAIMS .....	14
SC 13 – COST OF THE WORK .....	14
SC 13.01B5F COST OF THE WORK .....	15
SC 13.01C COSTS EXCLUDED .....	15
SC 13.03 UNIT PRICE WORK .....	15
SC 14 – TESTS AND INSPECTIONS.....	15
SC 14.02 TESTS AND INSPECTIONS .....	15
SC 15 – PAYMENT TO CONTRACTOR.....	15
SC 15.01 PROGRESS PAYMENTS.....	15
SC 15.05 FINAL INSPECTION.....	16
SC 15.06 FINAL PAYMENT .....	16
SC 15.08 CORRECTION PERIOD .....	17
SC 17 – FINAL RESOLUTION OF DISPUTES.....	18
SC 17.01 METHODS AND PROCEDURES.....	18

## **SC 0 INTRODUCTION**

These Supplementary General Conditions amend or supplement the Standard General Conditions of the Construction Contract (EJCDC C-700, 2013 Edition) and other provisions of the Contract Documents as indicated below. All provisions, which are not so amended or supplemented, remain in full force and effect.

## **SC 1 – DEFINITIONS AND TERMINOLOGY**

### **SC 1.01 DEFINED TERMS**

The terms used in these Supplementary Conditions, which are defined in the Standard General Conditions of the Construction Contract (C-700, 2013 Edition), have the meanings assigned to them in the General Conditions. Owner shall mean the City of Fridley, 6431 University Avenue, Fridley, MN 55432. Engineer shall mean the City Engineer of the City of Fridley or the Engineer representing the Owner on the project. Department shall mean the City of Fridley Engineering Department. Contractor shall mean the individual or entity with whom the Owner has entered into the Agreement.

## **SC 2 – PRELIMINARY MATTERS**

### **SC 2.01 DELIVERY OF BONDS AND EVIDENCE OF INSURANCE**

Delete paragraph 2.01B and insert the following:

Before any work at the site is started, Contractor shall deliver to Owner, with a copy to Engineer, certificates (and other evidence of insurance requested by Owner) which Contractor is required to purchase and maintain in accordance with paragraphs 5.03B and 5.04.

### **SC 2.02.A COPIES OF DOCUMENTS**

Amend the first sentence of Paragraph 2.02.A. to read as follows:

Owner shall furnish to Contractor two (2) copies of the Contract Documents (including one fully executed counterpart of the Agreement), and one copy in electronic portable document format (PDF).

### **SC 2.03 BEFORE STARTING CONSTRUCTION**

Paragraph 2.03.A of the General Conditions shall be deleted in its entirety and replaced by the following paragraphs.

B. Within ten (10) days after the Effective Date of the Agreement (unless otherwise specified in the General Requirements) and before the preconstruction conference, Contractor shall submit to Engineer the following for its timely review.

1. The Contractor shall submit in writing to the Engineer for review a progress schedule indicating the order in which the Contractor proposes to perform the various stages of the Work, the dates on which the Contractor will start the various features thereof, and the contemplated dates for completing the same. This schedule shall be in the form of a bar chart of a suitable scale to indicate appropriately the percentage of work scheduled and completed by weekly schedules. The lack of a schedule shall be cause

for withholding of progress payments and could result in a work stoppage. If the work is stopped, no credit of working days or payment of down time will be provided. The Contractor shall not deviate from this schedule after once approved without the written permission of the Engineer. The progress schedule will be acceptable to the Engineer if it provides an orderly progression of the Work to completion within any specified Milestones and the Contract Times. Such acceptance will not impose on the Engineer responsibility for the progress schedule of the Work nor interfere with or relieve the Contractor from the Contractor's full responsibility therefore.

2. The Contractor shall present to the Engineer two (2) copies of detailed, dimensioned manufacturer's drawings of all materials, apparatus and machinery, and for such fittings and devices as the Engineer may direct. The Engineer will keep one (1) copy and return the rest to the Contractor with the Engineer's notations. If required, the Contractor shall submit new drawings, corrected as noted by the Engineer. All such drawings shall be submitted to the Engineer with ample time allowance for consideration. Submittals shall be required for, but not limited to: Manhole Structures, Castings, Sewer Pipe, Water Main, Lift Stations, and Waterworks Brass.

3. The Engineer's approval of such drawings and progress schedules shall not relieve the Contractor from responsibility for deviations from drawings or specifications unless the Contractor has, in writing, called the Engineer's attention to such deviations at the time of submission, nor shall it relieve the Contractor from the responsibility for errors of any sort in shop drawings or progress schedules. No Work shall be started until the drawings and progress schedules have been approved by the Engineer.

#### **SC 2.05 INITIAL ACCEPTANCE OF SCHEDULES**

Paragraph 2.05 of the General Conditions shall be deleted in its entirety.

### **SC 3 - DOCUMENTS**

#### **SC 3.02 REFERENCE STANDARDS**

Add new paragraphs immediately after 3.02.A.2 of the General Conditions, which are to read as follows:

3. The work shall be performed in accordance with:
  - a. The 2018 edition of the Minnesota Department of Transportation "Standard Specifications for Highway Construction," (MnDOT Specifications) or amendments thereto issued prior to the date of the Contract Documents, including the current MnDOT 2360 Plant Mixed Asphalt Pavement Specification;
  - b. The City of Fridley 2018 General Specifications and Standard Detail Plates for Road and Utility Construction dated April 2018;
  - c. The 2013 Edition of the Standard Utilities Specifications for Water Main and Service Line Installation and Sanitary Sewer and Storm Sewer Installation as published by the League of Minnesota Cities, St. Paul, Minnesota, and Standard Detail Plates; and



d. The Project Manual, which contain individual project Bidding Requirements, Proposal Form, Conditions of the Contract, Contract Forms, Specifications, and any other project-specific information in the form of appendices. Traffic control shall be in accordance with the current edition of the Minnesota Manual on Uniform Traffic Control Devices (MMUTCD), including the current edition of the Field Manual for Temporary Traffic Control Zone Layouts. The provisions for construction shall comply with the following precedence (“1” being the highest precedence, “3” being the lowest):

- 1) Individual Project Plan
- 2) Individual Project Manual
- 3) MnDOT Standard Specifications for Construction

Any conflicting requirements or language shall follow that stated in the highest precedence document of those listed above, unless directed in writing by the Engineer.

4. Coordination of Plans and Specifications shall be in accordance with the provisions of MnDOT Specification 1504, as modified by the following definitions:

a. Standard Specification: Refer in precedent order to the current Standard Utilities Specifications of the City Engineers Association of Minnesota, the current MnDOT Standard Specifications and the other specifications of ASTM, ANSI, AWWA, etc., as referenced and as published on the date of the bid advertisement.

b. Supplemental Specifications: Refer in precedent order to the Supplementary Conditions and the General Conditions as contained in these Contract Documents.

c. Work under these Contract Documents shall be governed by all applicable federal, state, and local laws, regulations, codes and ordinances, and the Contract Documents, which are as follows:

General Conditions  
Supplementary Conditions  
General Requirements  
Special Provisions  
Addenda  
Proposal  
Contract Documents  
Technical Specifications

Should the Contract Documents conflict with any of the regulations and standards mentioned in preceding paragraphs of these Supplementary Conditions, the regulations and standards shall take precedence. This shall not, however, be construed to relieve the Contractor from complying with the requirements of the Contract Documents, which are in excess of, but not contrary to, the regulations and standards.

**SC 4 – COMMENCEMENT AND PROGRESS OF WORK**

**SC 4.03 REFERENCE POINTS**

Add new paragraphs immediately after 4.03.A of the General Conditions, which are to read as follows:

B. All property corner monuments and section corners known by the Engineer will be marked prior to construction. Any such monuments required to be removed by the proposed construction will be replaced at the Owner's expense. Any such monuments outside the proposed construction limits shall be protected by the Contractor. Should any monuments outside the proposed construction limits be disturbed, a Licensed Land Surveyor will reset them at the Contractor's expense.

B. The Engineer will provide one set of horizontal and vertical control stakes as requested by the Contractor. The Contractor will be responsible for protecting and maintaining these stakes. Additional stakes within the project area previously staked will be completed at the Contractors expense.

C. The Contractor shall give the Engineer forty-eight (48) hour notice of need for the establishment of line and grade so that the Engineer may have time to provide them. No additional compensation shall be allowed by the Contractor for any claims of crews being held up because of lack of line and grade stakes. It shall be the Contractor's total responsibility to accurately construct the streets and utilities in accordance with the construction stakes and bringing any discrepancies to the attention of the Engineer.

**SC 4.04 PROGRESS SCHEDULE**

Paragraph 4.04.A of the General Conditions shall be deleted in its entirety.

**SC 5 –AVAILABILITY OF LANDS, ETC.**

**SC 5.03 SUBSURFACE AND PHYSICAL CONDITIONS**

Add new paragraphs immediately after 5.03.B of the General Conditions, which are to read as follows:

C. Notwithstanding Paragraphs 5.03.A and 5.03.B, under no circumstances may the Contractor rely upon the accuracy of the "technical data" contained in reports of explorations or tests of the amounts, elevations, or locations of subsurface groundwater.

**SC 5.04 DIFFERING SUBSURFACE OR PHYSICAL CONDITIONS**

Amend paragraph 5.04.d.2.a. by inserting in the second line of this paragraph immediately after the word "conditions" the following: "or reasonably should have known thereof."

**SC 5.05B UNDERGROUND FACILITIES**

Add new paragraph immediately after Paragraph 5.05.B to read as follows:

1. Underground utility locations can be obtained from the following owners and services:

<b>Utility</b>	<b>Owner</b>	<b>Phone</b>
Location Service	Gopher State One Call	Metro: 651.454.0002 Out State: 800.252.1166

**SC 5.06I HAZARDOUS ENVIRONMENTAL CONDITION AT SITE**

Paragraph 5.06I of the General Conditions shall be deleted in its entirety.

**SC 6 – BONDS AND INSURANCE**

**SC 6.01B PERFORMANCE, PAYMENT, AND OTHER BONDS**

The first sentence of this section is changed to read as follows:

All bonds shall be in a form acceptable to Owner and shall fulfill statutory requirements

**SC 6.03 CONTRACTOR'S LIABILITY INSURANCE**

The following supplementary conditions are for City street and utility construction contracts.

Add the following new paragraph immediately after Paragraph 6.03.J:

K. The limits of liability for the insurance required by Paragraph 6.03 of the General Conditions shall provide coverage for not less than the following amounts or greater where required by Laws and Regulations:

1. Worker's Compensation and related coverages under Paragraphs 6.03.A.1 and A.2 of the General Conditions:

- a. State: Statutory
- b. Federal, if applicable (e.g., Longshoreman's): Statutory
- c. Employer's Liability: \$2,000,000

2. Contractor's Commercial General Liability under Paragraphs 6.03.B and 6.03.C of the General Conditions:

- a. General Aggregate \$2,000,000
- b. Products - Completed Operations Aggregate \$2,000,000
- c. Personal and Advertising Injury \$2,000,000
- d. Each Occurrence (Bodily Injury and Property Damage) \$2,000,000

4. Automobile Liability under Paragraph 6.03.D of the General Conditions:

- a. Bodily Injury:
  - Each person \$2,000,000
  - Each Accident \$2,000,000

6. Excess or Umbrella Liability

- a. General Aggregate \$2,000,000
- b. Each Occurrence \$2,000,000

7. Additional Insureds: Include the following as additional insureds:

- a. City of Fridley, Minnesota

**SC 6.04 OWNER'S LIABILITY INSURANCE**

Paragraph 6.04A of the General Conditions shall be deleted in its entirety.

### **SC 6.05 PROPERTY INSURANCE**

Delete paragraph 6.05 in its entirety and insert the following:

Builder's Risk Insurance: Before commencement of the Work, the Contractor shall provide Builder's Risk Insurance on a multiple peril form in the full amount of the total construction and material contract. Such insurance shall contain an appropriate rider to include as Additional Named Insureds, the Owner, the Engineer and his consultants, and each of their officers, employees and agents, all subcontractors, the equipment contractors and all of their subcontractors on the construction premises. Such insurance may have a deductible clause but the deductible amount shall be borne by the Contractor and shall not exceed \$1,000.00.

The Builder's Risk Insurance required herein shall apply to projects involving construction of structures and building only. The requirements of this section shall be waived on projects involving only underground utilities, grading, street improvements and similar construction work, but any damage or loss to property shall be the sole responsibility of the Contractor until final acceptance of the Work.

### **SC 6.06 WAIVER OF RIGHTS**

Paragraph 6.06 of the General Conditions shall be deleted in its entirety.

## **SC 7 – CONTRACTORS RESPONSIBILITY**

### **SC 7.02 LABOR; WORKING HOURS**

Add the following to 7.02 B of the General Conditions to read as follows: Working hours shall be restricted to the hours of 7:00 a.m. to 7:00 p.m. Monday through Friday. Saturday hours are 9:00 a.m. to 7:00 p.m. but require authorization from the Engineer. Expansion of working hours, including Sundays and Federal Holidays are not permitted.

### **SC 7.06 CONCERNING SUBCONTRACTORS, SUPPLIERS, AND OTHERS**

At the end of the paragraph 7.06 A add the following: The provisions of Minn. Stat. 16C.285 are imposed as a requirement of this contract. All bidders and persons or companies providing a response/submission to the Advertisement for Bids/RFP of the City shall comply with the provisions of the statute.

- a. Any prime contractor or subcontractor that does not meet the minimum criteria established for a "responsible contractor" as defined in Minn. Stat. § 16C.285, subd. 3, or fails to verify that it meets those criteria is not a responsible contractor and is not eligible to be awarded a construction contract for the Project or to perform work on the Project.
- b. Responding contractors shall submit to the City a signed statement under oath by an owner or officer verifying compliance with each of the minimum criteria in Minn. Stat. §16C.285, subd.3, at the time that it responds to this solicitation document.
- c. A prime contractor shall submit to the City, upon request, copies of the signed verifications of compliance from all subcontractors.

d. A false statement under oath verifying compliance with any of the minimum criteria shall make the prime contractor or subcontractor that makes the false statement ineligible to be awarded a construction project and may result in termination of a contract awarded to a prime contractor or subcontractor that submits a false statement. At the end of the paragraph 7.06.O.2 add the following: In accordance with Minnesota Statute 471.425, the Contractor shall pay any subcontractor within ten days of the Contractor's receipt of payment from the municipality.

#### **SC 7.09 TAXES**

Add a new paragraph immediately after Paragraph 7.09.A:

B. Refer to Special Provisions.

#### **SC 7.10 LAWS AND REGULATIONS**

Add Paragraph D: DATA PRACTICES ACT

The Contractor must comply with the Minnesota Government Data Practices Act, Minnesota

Statutes Chapter 13, as it applies to (1) all data provided by the Owner pursuant to this

Agreement, and (2) all data, created, collected, received, stored, used, maintained, or disseminated by the Contractor pursuant to this Agreement. The Contractor is subject to all the provisions of the Minnesota Government Data Practices Act, including but not limited to the civil remedies of Minnesota Statutes Section 13.08, as if it were a government entity. In the event the Contractor receives a request to release data, the Contractor must immediately notify the Owner.

The Owner will give the Contractor instructions concerning the release of the data to the requesting party before the data is released. Contractor agrees to defend, indemnify, and hold the Owner, its officials, officers, agents, employees, and volunteers harmless from any claims resulting from Contractor's officers', agents', owners', partners', employees', volunteers', assignees' or subcontractors' unlawful disclosure and/or use of protected data. The terms of this paragraph shall survive the cancellation or termination of this Agreement.

#### **SC 7.12 SAFETY AND PRECAUTION**

Add a new paragraph immediately after 7.12.G of the General Conditions, which is to read as follows:

The Contractor shall provide all necessary temporary barricades, fences and other protection as required for the proper execution of the work and for the protection of his employees, employees of the Owner, other construction personnel, and the general public according to all Federal, State, and Local regulations. This may include increased signing as necessary. The Contractor may need to furnish, erect, and maintain lights to provide a safe work environment according to all state and federal codes. All utility trenches shall be backfilled at the end of each working day and driveway access provided to individual residences to the satisfaction of the Engineer. ***The Contractor shall immediately call "911" if a gas utility line is struck or damaged.***

#### **SC 7.18 INDEMNIFICATION**

Add the following as a subparagraph of 7.18.C.2 of the General Conditions to read as follows:

Provided however, if the claim, damage, loss or expense referred to in Paragraph 67.18A results from failure of the ENGINEER to discover a condition or object which is underground or otherwise not reasonably observable by the ENGINEER, and if said failure to discover is apparent to the CONTRACTOR in that the said condition or object is omitted from the ENGINEER'S maps, drawings, opinions, reports, surveys, change orders, designs or specifications, then the CONTRACTOR shall be liable for indemnification of ENGINEER under Paragraph 7.18 for damage resulting from said failure to discover unless CONTRACTOR shall have notified ENGINEER of the existence and location of such condition or object prior to the occurrence of such damage and in sufficient time of ENGINEER to have provision therefore. Further, in the event neither ENGINEER nor CONTRACTOR discover such condition or object, CONTRACTOR shall bear the burden of indemnification under Paragraph 7.18.

## **SC 8 – OTHER WORK ON SITE**

### **SC 8.01 RELATED WORK AT SITE**

Add the following to 8.01.C of the General Conditions to read as follows:

The Contractor shall cooperate with all parties to facilitate the prompt completion of all contracts. Add the following immediately after 8.01.D of the General Conditions, which is to read as follows:

D. The Contractor is hereby advised that the following work may be performed on the site by others during the contract time.

1. The property owners or their agents may be working on their lot, or home.
2. Private utility companies may be installing and/or relocating underground facilities on or adjacent to the project.

E. If Owner performs work for the Contractor, the Contractor must pay Owner for such work with no deduction in Contract amount.

## **SC 9 – OWNERS RESPONSIBILITY**

### **SC 9.11 EVIDENCE OF FINANCIAL ARRANGEMENTS**

Paragraph 9.11 of the General Conditions shall be deleted in its entirety.

## **SC 10 – ENGINEERS STATUS DURING CONSTRUCTION**

### **SC 10.02 VISITS TO SITE**

Add a new paragraph immediately after 10.02.B of the General Conditions, which is to read as follows:

C. Throughout the construction phase, regular weekly meetings will be held by the Engineer on site, or at Fridley City Hall, to review progress and to discuss items necessary for an orderly completion of the

project. The weekly construction meetings shall include the Owner, Engineer and Contractor. The Contractor's representative must be able to make decisions for the Contractor pertaining to the project. All project conflicts shall be brought to these meetings, including requests for additional payment. Meeting minutes will be provided to all participants as a record of the meeting.

### **SC-10.03**

Add the following new paragraphs immediately after Paragraph 10.03.A:

- B. The Resident Project Representative (RPR) will be Engineer's representative at the Site, will act as directed by and under the supervision of Engineer, and will confer with Engineer regarding RPR's actions.
  - 1. General: RPR's dealings in matters pertaining to the Work in general shall be with Engineer and Contractor. RPR's dealings with Subcontractors shall only be through or with the full knowledge and approval of Contractor. RPR shall generally communicate with Owner only with the knowledge of and under the direction of Engineer.
  - 2. Schedules: Review the progress schedule, schedule of Shop Drawing and Sample submittals, and Schedule of Values prepared by Contractor and consult with Engineer concerning acceptability.
  - 3. Conferences and Meetings: Attend meetings with Contractor, such as preconstruction conferences, progress meetings, job conferences, and other Project-related meetings, and prepare and circulate copies of minutes thereof.
  - 4. Liaison:
    - a. Serve as Engineer's liaison with Contractor. Working principally through Contractor's authorized representative or designee, assist in providing information regarding the provisions and intent of the Contract Documents.
    - b. Assist Engineer in serving as Owner's liaison with Contractor when Contractor's operations affect Owner's on-Site operations.
    - c. Assist in obtaining from Owner additional details or information, when required for proper execution of the Work.
  - 5. Interpretation of Contract Documents: Report to Engineer when clarifications and interpretations of the Contract Documents are needed and transmit to Contractor clarifications and interpretations as issued by Engineer.
  - 6. Shop Drawings and Samples:
    - a. Record date of receipt of Samples and Contractor-approved Shop Drawings.
    - b. Receive Samples which are furnished at the Site by Contractor, and notify Engineer of availability of Samples for examination.

- c. Advise Engineer and Contractor of the commencement of any portion of the Work requiring a Shop Drawing or Sample submittal for which RPR believes that the submittal has not been approved by Engineer.
- 7. Modifications: Consider and evaluate Contractor's suggestions for modifications in Drawings or Specifications and report such suggestions, together with RPR's recommendations, if any, to Engineer. Transmit to Contractor in writing decisions as issued by Engineer.
- 8. Review of Work and Rejection of Defective Work:
  - a. Conduct on-Site observations of Contractor's work in progress to assist Engineer in determining if the Work is in general proceeding in accordance with the Contract Documents.
  - b. Report to Engineer whenever RPR believes that any part of Contractor's work in progress is defective, will not produce a completed Project that conforms generally to the Contract Documents, or will imperil the integrity of the design concept of the completed Project as a functioning whole as indicated in the Contract Documents, or has been damaged, or does not meet the requirements of any inspection, test or approval required to be made; and advise Engineer of that part of work in progress that RPR believes should be corrected or rejected or should be uncovered for observation, or requires special testing, inspection or approval.
- 9. Inspections, Tests, and System Start-ups:
  - a. Verify that tests, equipment, and systems start-ups and operating and maintenance training are conducted in the presence of appropriate Owner's personnel, and that Contractor maintains adequate records thereof.
  - b. Observe, record, and report to Engineer appropriate details relative to the test procedures and systems start-ups.
- 10. Records:
  - a. Prepare a daily report or keep a diary or log book, recording Contractor's hours on the Site, Subcontractors present at the Site, weather conditions, data relative to questions of Change Orders, Field Orders, Work Change Directives, or changed conditions, Site visitors, deliveries of equipment or materials, daily activities, decisions, observations in general, and specific observations in more detail as in the case of observing test procedures; and send copies to Engineer.
  - b. Record names, addresses, fax numbers, e-mail addresses, web site locations, and telephone numbers of all Contractors, Subcontractors, and major Suppliers of materials and equipment.
  - c. Maintain records for use in preparing Project documentation.



11. Reports:
    - a. Furnish to Engineer periodic reports as required of progress of the Work and of Contractor's compliance with the Progress Schedule and schedule of Shop Drawing and Sample submittals.
    - b. Draft and recommend to Engineer proposed Change Orders, Work Change Directives, and Field Orders. Obtain backup material from Contractor.
    - c. Immediately notify Engineer of the occurrence of any Site accidents, emergencies, acts of God endangering the Work, force majeure or delay events, damage to property by fire or other causes, or the discovery of any Constituent of Concern or Hazardous Environmental Condition.
  12. Payment Requests: Review applications for payment with Contractor for compliance with the established procedure for their submission and forward with recommendations to Engineer, noting particularly the relationship of the payment requested to the Schedule of Values, Work completed, and materials and equipment delivered at the Site but not incorporated in the Work.
  13. Certificates, Operation and Maintenance Manuals: During the course of the Work, verify that materials and equipment certificates, operation and maintenance manuals and other data required by the Contract Documents to be assembled and furnished by Contractor are applicable to the items actually installed and in accordance with the Contract Documents, and have these documents delivered to Engineer for review and forwarding to Owner prior to payment for that part of the Work.
  14. Completion:
    - a. Participate in Engineer's visits to the Site to determine Substantial Completion, assist in the determination of Substantial Completion and the preparation of a punch list of items to be completed or corrected.
    - b. Participate in Engineer's final visit to the Site to determine completion of the Work, in the company of Owner and Contractor, and prepare a final punch list of items to be completed and deficiencies to be remedied.
    - c. Observe whether all items on the final list have been completed or corrected and make recommendations to Engineer concerning acceptance and issuance of the notice of acceptability of the work.
- C. The RPR shall not:
1. Authorize any deviation from the Contract Documents or substitution of materials or equipment (including "or-equal" items).
  2. Exceed limitations of Engineer's authority as set forth in the Contract Documents.
  3. Undertake any of the responsibilities of Contractor, Subcontractors, or Suppliers.

4. Advise on, issue directions relative to, or assume control over any aspect of the means, methods, techniques, sequences or procedures of Contractor's work, including verification of grades or layout.
5. Advise on, issue directions regarding, or assume control over security or safety practices, precautions, and programs in connection with the activities or operations of Owner or Contractor.
6. Participate in specialized field or laboratory tests or inspections conducted off-site by others except as specifically authorized by Engineer.
7. Accept Shop Drawing or Sample submittals from anyone other than Contractor.
8. Authorize Owner to occupy the Project in whole or in part.

#### **SC 10.08 LIMITATION ON ENGINEER'S AUTHORITY AND RESPONSIBILITIES**

Add the following at the end of the first sentence of paragraph 10.08A:

Insofar as the subject matter of any pertinent claim, dispute, or other matter falls within the realm of the technical expertise of ENGINEER, ENGINEER shall not render any decision on any claims, disputes, or other matters the subject matter of which, at ENGINEER'S sole discretion, requires legal, rather than technical interpretation.

#### **SC 12 – CLAIMS**

##### **SC 12.01 CLAIMS**

The first sentence of Paragraph 12.01.B of the General Conditions shall be deleted and the following inserted in its place: Written notice stating the general nature of each Claim, dispute, or other matter shall be delivered by the claimant to the Engineer and the other party to the Contract promptly but in no event later than ten (10) days after the start of the event giving rise thereto. Add the following paragraphs to 12.01F of the General Conditions to read as follows:

Except as specifically authorized in writing by the Engineer at the time additional work is done beyond the original scope of the Contract Documents, the Contractor shall make no claims for additional compensation. The Contractor's plea of ignorance of foreseeable conditions which will create difficulties or hindrances in the execution of the work will not be acceptable to the Owner as an excuse for any failure of the Contractor to fulfill the requirements of the Contract

Documents, and shall not be a basis for the Contractor's claim for additional compensation.

Any discrepancies in or conflicts between the items described in these Contract Documents must be submitted in writing to the Engineer for adjustment prior to proceeding with the work as any claims for additional compensation to achieve compliance with the requirements of those items will not be allowed or considered.

#### **SC 13 – COST OF THE WORK**

**SC 13.01B5F COST OF THE WORK**

Paragraph 13.01B5F of the General Conditions shall be deleted in its entirety.

**SC 13.01C COSTS EXCLUDED**

Insert the following after Paragraph 13.01C.5:

6. Sales, consumer, use and other similar taxes related to the Work for which CONTRACTOR is liable.

**SC 13.03 UNIT PRICE WORK**

Delete paragraph 13.03.E in its entirety and insert the following in its place.

There will be no adjustment in unit price for increased or decreased quantities. In addition, the Owner reserves the right to reduce certain quantities or delete certain items from each section of the bids as the Owner sees fit, either before or after the Award of Contract. There will be no additional compensation due to remobilization of equipment as necessary to complete punch list items or other items not completed by the Contractor. There will be no additional compensation due to restocking charges for materials not used on the project.

**SC 14 – TESTS AND INSPECTIONS**

**SC 14.02 TESTS AND INSPECTIONS**

Add the following paragraphs to 14.02.A of the General Conditions to read as follows:

The Contractor shall provide a minimum twenty-four (24) hour notice to the RPR for any testing that must be observed or accomplished by someone other than the Contractor’s personnel. All final tests and inspections shall be performed under the observation of the Resident Project RPR. All tests on material to be placed shall be completed prior to the placing of any material. Tests shall be made in accordance with the American Society for Testing and Materials (ASTM) standard and tentative specifications that apply, except as otherwise specified. Signed copies of all reports on tests shall be sent at once to the Owner, Engineer and Contractor. Inspection and testing shall in no way relieve the Contractor or supplier from the responsibility of furnishing materials and workmanship in accordance with the plans and specifications.

**SC 15 – PAYMENT TO CONTRACTOR**

**SC 15.01 PROGRESS PAYMENTS**

Amend paragraph 15.01B.3 of the General Conditions to read as follows:

The amount of retainage with respect to all progress payments will be as follows:

- Minnesota Contractors 5%
- Exempt Non-Minnesota Contractors 5%
- Non-Exempt Non-Minnesota Contractors 5% + 8%\* = 13%
- \*State Surety Deposit

Non-Minnesota Contractors are advised to file Form SDE with the Minnesota Department of Revenue to determine their exemption status. No reduction in retainage will be allowed until final acceptance of entire project, unless approved by the Engineer.

Delete paragraph 15.01.D.1 in its entirety and replace with the following paragraphs:

1. Thirty days after presentation of the Application for Payment to owner with ENGINEER'S recommendation, the amount recommended (subject to the provision of paragraph 15.01.D) will become due and when due will be paid by OWNER to CONTRACTOR, unless extenuating circumstances exist which would preclude such payment by OWNER to CONTRACTOR. If such extenuating circumstances exist, then payment shall be made within forty-five (45) days after OWNER receives presentation of the Application for Payment.

2. Pursuant to Minnesota Statute 471.425, Subdivision 4a, the Contractor must pay any subcontractor within ten (10) days of the Contractor's receipt of payment from the City for undisputed services provided by the subcontractor. The Contractor must pay interest of one and one-half percent (1 ½ %) per month or any part of a month to the subcontractor on any undisputed amount not paid on time to the subcontractor. The minimum monthly interest penalty payment for an unpaid balance of \$100.00 or more is \$10.00. For an unpaid balance of less than \$100.00, the Contractor shall pay the actual penalty due to the subcontractor. A subcontractor who prevails in a civil action to collect interest penalties from the Contractor shall be awarded its costs and disbursements, including attorney's fees, incurred in bringing the action.

#### **SC 15.03.B PAYMENTS TO CONTRACTOR**

Add the following new subparagraph to Paragraph 15.03.B:

1. If some or all of the Work has been determined not to be at a point of Substantial Completion and will require re-inspection or re-testing by Engineer, the cost of such re-inspection or re-testing, including the cost of time, travel and living expenses, shall be paid by Contractor to Owner. If Contractor does not pay, or the parties are unable to agree as to the amount owed, then Owner may impose a reasonable set-off against payments due under Article 15.

#### **SC 15.05 FINAL INSPECTION**

Add the following after the second sentence of paragraph 15.05.A of the General Conditions:

If, after such measures are taken, subsequent inspections by the Engineer reveal that any of the previously identified construction items remain incomplete or defective, the Engineer will again notify the Contractor in writing of the remaining construction items. All costs associated with any subsequent inspections in which said remaining particulars are revealed, will be documented by the Engineer and paid by the Contractor to the Owner.

#### **SC 15.06 FINAL PAYMENT**

Add a new paragraph immediately after paragraph 15.06.A.3 of the General Conditions, which is to read as follows:

4. Before final application for payment is made for the work, the Contractor must make satisfactory showing of compliance with M.S.A. 290.92, which requires the withholding of state income taxes for wages paid to employees on this project. Receipt by the Engineer of a certificate of Compliance from the Commissioner of Taxation to the Owner will satisfy this requirement. The Contractor is advised that before such certificate can be issued, the Contractor must first place on file with the Commissioner of Taxation an affidavit that the Contractor has complied with the provisions of M.S.A. 290.92. The required affidavit form will be supplied by the Commissioner of Taxation, Centennial Building, St. Paul, Minnesota, on request. Final payment will not be made until the Contractor shall have filed with the Engineer evidence in the form of an affidavit or such other evidence as may be required that all claims against him by reason of the Contract have been fully paid or satisfactorily secured. This shall be in the form of IC134 forms, paid-in-full final lien waivers from the Contractor, subcontractors, and major suppliers, and a Consent of Surety shall precede or accompany the final application for payment. In case such evidence is not furnished, the Owner may retain out of any monies due said Contractor sums sufficient to cover all lienable claims unpaid. In addition, a two (2) year maintenance bond is required from the Contractor. Said maintenance bond is to be dated to begin the date the City Council formally accepts the project.

**SC 15.08 CORRECTION PERIOD**

Amend the first sentence of paragraph 15.08.A of the General Conditions to read as follows:

If within two (2) years after the date of final acceptance of the project by the City Council; or such longer period of time as may be prescribed by Laws or Regulations; or by the terms of any

applicable special guarantee required by the Contract Documents; or by any specific provision of the Contract Documents, any Work that is found to be defective, or if the repair of any damages to the land or areas made available for the Contractor's use by the Owner or permitted by Laws and Regulations as contemplated in paragraph 6.11.A is found to be defective, the Contractor shall promptly, without cost to the Owner, and in accordance with the Owner's written instructions:

(i) Repair such defective land or areas, or

(ii) Correct such defective Work or, if the defective Work has been rejected by the Owner, remove it from the Project and replace it with Work that is not defective,

and

(iii) Satisfactorily correct or repair or remove and replace any damage to other Work,

to the work of others or other land or areas resulting there from.

With regards to any surface concrete work, including but not limited to sidewalks, curb, gutter, and driveway aprons within the project area, the Contractor shall assume full responsibility for any warranty work unless written approval is provided by the Owner releasing the Contractor from the responsibility for damages. The intent of this provision is to release the Contractor from accepting monetary losses for destruction of concrete sidewalk, curb, gutter, and driveway aprons due to damages and circumstances

out of the control of the Contractor. At no point during the two-year warranty period shall this relieve the Contractor's responsibility for correction of the defective work as stated in the preceding paragraph, or as caused by poor construction and defective materials on the concrete sidewalk, curb, gutter, and driveway aprons within the project area. The Owner or Engineer shall make the final determination of what material is defective within the project area at any point within the two-year warranty period.

## **SC 17 – FINAL RESOLUTION OF DISPUTES**

### **SC 17.01 METHODS AND PROCEDURES**

Article 17.01, Methods and Procedures, of the General Conditions shall be deleted in its entirety and replaced with the following paragraphs:

“In an effort to resolve any conflicts that arise during the design or construction of the project or following the completion of the project, the Contractor and the Engineer agree that all disputes between them arising out of or relating to this agreement shall be resolved, if possible, at the lowest possible staff level. If the dispute cannot be resolved between the Contractor and the Engineer staff, the presidents of the respective firms will meet to attempt to resolve the dispute(s).

If resolution is not achieved, the dispute shall be submitted to non-binding mediation. The rights and remedies available to the Contractor shall be limited to breach of Contract, and no other cause of action, including, without limitation, negligence, misrepresentation or other tort theory. The Owner or Contractor may assert any such breach of contract claim in any court of competent jurisdiction. Neither the Owner nor the Contractor shall be entitled to a jury trial in any such action. The right and remedies to the Owner hereunder shall be in addition to and shall not be constructed in any way as a limitation of any rights and remedies available to the Owner, which is otherwise available by law or contract, by special warranty or guarantee, or by other provision of the Contract documents.

The provision of this paragraph shall be as effective as if repeated specifically in the contract documents in connection with each particular duty, obligation, right and remedy to which it may apply. All representations, warranties and guarantees made in the Contract documents shall survive final payment, termination or completion of this agreement. No waiver or failure to enforce any part or provision of the contract documents, including but not limited to the change order process, shall be deemed to be waiver by the Owner of any subsequent default or breach of the same or any other part of provision contained herein, or right to enforce the same or any other part or provision contained herein.”

**DIVISION 01**

**GENERAL REQUIREMENTS**

**SECTION 1-SP**  
**SPECIAL PROVISIONS**



**Section 1- SP - Special Provisions – Table of Contents**

SECTION SP-SPECIAL PROVISIONS ..... 3

SP-1 ENGINEER'S RELATION ..... 3

SP-2 CONTRACTOR PERFORMANCE EVALUATION..... 3

SP-3 MATERIALS, SERVICES AND FACILITIES..... 3

SP-4 QUALIFICATIONS..... 4

SP-5 ALTERATION OF THE WORK..... 4

SP-6 MOBILIZATION/TRAFFIC CONTROL..... 4

SP-7 MAINTENANCE OF TRAFFIC (1404), PUBLIC SAFETY (1707)..... 5

SP-8 PHASING SCHEDULE ..... 6

SP-9 SEQUENCING / TRAFFIC DETOUR / TRAFFIC ACCESS ..... 6

SP-10 ADJUSTMENT OF MANHOLES & GATE VALVES ..... 6

SP-11 REMOVE AND INSTALL RINGS - EXTRA DEPTH..... 7

SP-12 STORM BARREL SECTIONS..... 8

SP-13 CONNECT TO EXISTING STORM SEWER ..... 8

SP-14 LOW PROFILE CASTING..... 8

SP-15 AGGREGATE BASE, CLASS 7, FULL DEPTH RECYCLED PRODUCTION..... 8

SP-16 AGGREGATE BASE PREPERATION ..... 9

SP-17 EXCESS RECLAIM DISPOSAL ..... 9

SP-18 TRUCK TRAFFIC ALLOWED ON NEW PAVEMENT (DAY OF PAVING) ..... 9

SP-19 EDGE MILL BITUMINOUS..... 10

SP-20 REMOVE & REPLACE PAVEMENT ..... 10

SP-21 REMOVE & REPLACE DRIVEWAY PAVEMENT ..... 10

SP-22 WALKS (ST-14) ..... 10

SP-23 CURB REPLACEMENT ..... 11

SP-24 CONCRETE GUARANTEE AND WARRANTY ..... 11

SP-25 TESTING ..... 11

SP-26 WATER ..... 11

SP-27 IRRIGATION SYSTEM..... 11

SP-28 PET FENCE ..... 12

SP-29 SILT FENCE..... 12

SP-30 ROCK CHECK DAM..... 12

SP-31 DEBRIS ..... 12

SP-32 STREET SWEEPING ..... 12

SP-33 RAIN GARDEN AND SWALES ..... 12

SP-34 SELECT TOPSOIL BORROW (ST-17) ..... 13

SP-35 SEED, FERTILIZER & HYDRAULIC SOIL STABILIZER ..... 13

SP-36 RIGHT-OF-WAY PERMITS..... 13

SP-37 NPDES PERMIT ..... 14  
SP-38 POLICE OFFICER..... 14  
SP-39 DEWATERING ..... 14  
SP-40 BACKFLUSH WATER SERVICE..... 14  
SP-41 AGGREGATE BASE PREPARATION AND WATER TRUCK (ST-13.2)..... 14  
SP-42 WEEKLY CONSTRUCTION MEETING ..... 14

## **SECTION SP-SPECIAL PROVISIONS**

### **SP-1 ENGINEER'S RELATION**

The Engineer shall be interpreted to mean the Director of Public Works, his Assistant, or designated representative.

The Engineer shall act as the City's representative during the construction period, and shall decide questions which may arise as to quality and acceptability of materials furnished and work performed. The Engineer shall interpret the intent of the Contract Documents in a fair and unbiased manner and he will make visits to the site and determine if the work is proceeding in accordance with the Contract Documents. The Engineer shall promptly make all necessary explanations as to the meaning and intention of the specifications. The Engineer shall in all cases determine the amount, quality, acceptability and fitness of the several kinds of work and materials which are to be paid for under this contract. The decision of the Engineer shall be final and conclusive upon the City and the Contractor.

### **SP-2 CONTRACTOR PERFORMANCE EVALUATION**

Bidders shall note that the City of Fridley, while not using Best Value Contracting in accordance with M.S. 16C.28 as a basis of award for this project, reserves the right to evaluate Contractor's performance for this project and further use this performance as a basis for future project awards in accordance with M.S. 16C.28. Criteria upon which the Contractor may be evaluated for future project awards may include, but is not limited to the following:

- (1) the quality of the Contractor's performance on this project;
- (2) the timeliness of the Contractor's performance on this project;
- (3) the level of customer satisfaction with the Contractor's performance on this project;
- (4) the Contractor's record of completing this project on budget and ability to minimize cost overruns;
- (5) the Contractor's ability to minimize change orders;
- (6) the Contractor's ability to complete the project in accordance with the contract documents;
- (7) the Contractor's technical capacities;
- (8) the individual qualifications of the contractor's key personnel; and
- (9) the Contractor's ability to assess and minimize risks.

### **SP-3 MATERIALS, SERVICES AND FACILITIES**

It is understood that, except as otherwise specifically stated in the Contract Documents, the Contractor shall provide and pay for all materials, labor, tools, equipment, water, light, power, barricades, transportation, supervision, temporary construction of any nature, and all other services and facilities of any nature whatsoever necessary to execute, complete, and deliver the work.

**SP-4 QUALIFICATIONS**

The apparent low-bidder, prior to the award of the contract, if requested by the City, will be required to show evidence of prior work of similar character completed during the past 36 months.

Each bidder is required to show proof that he has, within the last three (3) years, successfully completed similar work. The Director of Public Works may require the apparent low bidder on this project to submit three references to verify where he has completed such similar work. The low bidder may also be required to submit a written statement showing the experience of the bidder and the amount of capital and equipment he has available for performance of the proposed work. If requested by the City, the Contractor and his subcontractors shall furnish lien waivers or certified statements from any party furnishing materials or rendering service in connection with this project, that certify said party has been paid in full.

The right is reserved to reject any or all proposals, to waive defects and technicalities, or to advertise for new proposals, if in the judgment of the City its best interests will be promoted thereby.

**SP-5 ALTERATION OF THE WORK**

The Provisions of 1402 are supplemented as follows:

The Engineer reserves the right to delete any sub-project contained in this Proposal and as shown in the Plans, in part or in its entirety, at any time. No contract adjustments will be made for any increased expenses due to loss of expected reimbursement, or loss of anticipated profits suffered or claimed by the Contractor by reason of a sub-project deletion.

**SP-6 MOBILIZATION/TRAFFIC CONTROL**

Bidding

The cumulative total cost of Mobilization and Traffic Control shall not be greater than eight percent (8.0%) of the total contract price. For example, if the total contract price is \$100,000.00 the maximum cumulative total cost of Mobilization and Traffic Control would be \$8,000.00. If the cumulative total cost of both items is greater than eight percent (8.0%), the bidder shall be disqualified and the Proposal shall be rejected.

Payment

Based on the lump sum Contract price for Mobilization and Traffic Control, partial payments for each will be made as follows:

1. On the first monthly partial estimate that shows work exceeding 5% of the original Contract has been completed, exclusive of the Mobilization and Traffic Control items, fifty percent (50%) of the amount bid for Mobilization and Traffic Control will be paid.
2. When work exceeds 50% of the original contract, subsequent monthly partial estimates will be pro-rated to reflect the percentage of work performed, exclusive of the Mobilization and Traffic Control items.
3. When a monthly partial estimate shows that seventy-five percent (75%) or more of the original Contract has been completed, exclusive of the Mobilization and Traffic Control items, one hundred percent (100%) of the amount bid for Mobilization and Traffic Control will be paid on that estimate.

**SP-7 MAINTENANCE OF TRAFFIC (1404), PUBLIC SAFETY (1707)**

The provisions of MnDOT S.S.-1404 and 1707 are supplemented as follows:

The Contractor shall furnish, install, maintain, and remove all traffic control devices required to provide safe movement of vehicular and/or pedestrian traffic passing through the work zone during the life of the Contract from the start of Contract operations to the final completion thereof. The Engineer will have the right to modify the requirements for traffic control as deemed necessary due to existing field conditions.

Traffic control devices include, but are not limited to, barricades, warning signs, trailers, flashers, cones, drums, pavement markings and flaggers as required and sufficient barricade weights to maintain barricade stability.

The Contractor shall furnish names, addresses, and phone numbers of at least three (3) individuals responsible for the placement and maintenance of traffic control devices. At least one of these individuals shall be "on call" 24 hours per day, seven days per week during the times any traffic control devices, furnished and installed by the Contractor, are in place. The required information shall be submitted to the Engineer at the Pre-construction Conference. The Contractor shall also furnish the names, addresses, and phone numbers of those individuals to the following:

1. Fridley Engineering Division                      763-572-3554
2. Fridley /Police Department                      763-572-3659
3. Fridley Fire Department                      763-572-3613
4. Fridley City Clerk                      763-572-3533

The Contractor shall, at the pre-construction conference, designate a Work Zone Safety Coordinator who shall be responsible for safety and traffic control management in the Project work zone. The Work Zone Safety Coordinator shall be either an employee of the Contractor such as a superintendent or a foreman, or an employee of a firm which has a subcontract for overall work zone safety and traffic control management for the Project. The responsibilities of the Work Zone Safety Coordinator shall include, but not be limited to:

- Coordinating all work zone traffic control operations of the Project, including those of the Contractor, subcontractors and suppliers.
- Establishing contact with local school district, government, law enforcement, and emergency response agencies affected by construction before work begins.
- Maintaining a record of all known crashes within a work zone. This record should include all available information, such as: time of day, probable cause, location, pictures, sketches, weather conditions, interferences to traffic, etc. These records shall be made available to the Engineer upon request.

The Contractor shall inspect, on a daily basis, all traffic control devices, which the Contractor has furnished and installed, and verify that the devices are placed in accordance with the Traffic Control Layouts, these Special Provisions, and/or the MN MUTCD. Any discrepancy between the placement and the required placement shall be immediately corrected. The person performing the inspection shall be required to make a daily log. This log shall also include the date and time any changes in the stages, phases, or portions thereof go into effect. The log shall identify the location and verify that the devices are placed as directed or corrected in accordance

with the Plan. All entries in the log shall include the date and time of the entry and be signed by the person making the inspection. The Engineer reserves the right to request copies of the logs as he deems necessary.

**Measurement and Payment:**

No measurement will be made of the various Items that constitute Traffic Control but all such work will be construed to be included in the single Lump Sum payment under Item 2563.601 (Traffic Control).

**SP-8 PHASING SCHEDULE**

The Contractor shall submit a phasing schedule of the project 7 calendar days prior to the pre-construction meeting to the Engineer for approval. Proposed phasing shall:

- Be divided up such that no one phase is greater than 7,000 lineal feet (centerline).
- Be scheduled such that newly constructed streets shall not serve as haul routes for truck traffic unless specifically approved by the Engineer.
- Minimize disruption to property owners and ensure that access point closures to the project area are minimized and must be acceptable to the Engineer.

**SP-9 SEQUENCING / TRAFFIC DETOUR / TRAFFIC ACCESS**

The Contractor shall provide a detour during asphalt paving for through streets. Signage denoting proposed detour shall be in place 72 hours prior to detour. Contractor shall provide notices to the properties 48 hours prior to paving. A detour plan shall be provided to the Engineer for review and approval. The Contractor may provide an alternative to a detour for consideration by the Engineer. Payment for all work relating to the detour shall be included in the traffic control pay item.

The Contractor shall restrict access to the street on the day of paving. The Contractor shall propose a closure time to the Engineer for approval. The Contractor is responsible to provide flaggers and barricades to restrict traffic until the Engineer has determined access shall no longer be restricted.

The Contractor shall be required to maintain local traffic during the period of construction. The property owners shall have access to their properties except during paving operations or utility work adjacent to their property. The Contractor shall schedule work such that property owners shall have access to their properties at the end of each working day by 7:00 P.M.

The Contractor shall distribute notices to adjacent property owners 48 hours prior to each process of milling, reclaiming, and paving. The City will provide the notices to the Contractor for distribution within four hours of the request of Contractor.

Contractor shall immediately notify Engineer of any unanticipated impacts to properties regarding use of utility services or site access. When directed by the Engineer, the Contractor may be required to notify property occupants in person as needed if construction unexpectedly impacts the use of their property.

**SP-10 ADJUSTMENT OF MANHOLES & GATE VALVES**

The material around the manholes and catch basins will be compacted using mechanical compaction methods to avoid any settlement around the structures. During excavation, aggregate base shall be separated from the underlying soils (i.e. sand) and reinstalled carefully to match existing base section. Dry soils encountered shall be watered to achieve increased density.

The Contractor may remove castings and install temporary metal covers on the masonry portion of the manholes and catch basins during the pavement milling and reclamation. The metal covers shall be supplied by the Contractor and will remain his property. **The contractor shall provide an acceptable tie to the casting in the boulevard at the time of casting removal and shall maintain the tie until final pavement is placed.** This tie must be conspicuous for city crews to find in the event of a utility emergency (i.e. sewer backup, water break, etc.).

### **Milled Street Segments**

All access castings for utilities shall be accessible and brought to grade or final grade within 3 calendar days after the street segment has been milled by the Contractor. The Contractor shall schedule his work so that access to water and sewer facilities (MH, GV, etc) are not restricted for more than 5 calendar days.

### **Reclaimed Street Segments**

All access castings for utilities shall be accessible and brought to grade or final grade within 3 calendar days after the street segment has received the first pavement layer by the Contractor.

The Contractor shall install an umbrella style material trap in the structural to contain any and all debris. **No structure work shall take place until the material trap has been installed.** Any debris missed by the material trap shall be removed from the bottom of the structure immediately. All structures shall be inspected and cleaned by the Contractor within 24 hours of adjusting the casting. The Engineer may verify inspection of structures and any structures found to contain construction debris, shall be cleaned immediately. If construction debris is not removed by 6:00 pm of the following day after installation, the City will clear the debris and charge the Contractor overtime rates.

MH and GV castings shall be raised prior to the final wearing course of bituminous. Minimum dimensions for MH patch shall be 4 x 4 foot perpendicular. Minimum dimensions for GV patch shall be 3 x 3 foot perpendicular. Sawcut shall be made around each casting in the base course or milled surface. The casting shall be installed such that the casting is between ¼ inch and ¾ inch below the top of the proposed wearing course (with no tolerance on final measurement). Concrete shall then be placed around the casting, filling the voids. **Castings and concrete rings shall be set to final elevation no less than 96 hours prior to paving wear course layer. If approved HDPE rings are used, set time prior to paving shall be reduced by the Engineer.**

The Contractor shall be responsible for replacing rings to a depth of 18 inches from top of casting (rim) for casting adjustments. Depth greater than 18" shall be considered additional depth.

The final patch shall have the edges sawcut or milled to provide a smooth edge. The condition of the cut/milled edge must be straight vertically and horizontally to the satisfaction of the Engineer. All portions of any previous pavement patch shall be removed. Edges shall be cleaned and tacked. The contractor shall furnish, install, and maintain a barricade with night protection for each MH and GV until the final layer is placed. The Contractor shall place the barricade immediately following completion of the adjustment to protect the facility. When the Contractor raises iron to the finish grade, the Contractor shall furnish, install, and maintain barricades with night protection for each MH and GV. There will be no additional compensation for the barricades with night protection.

### **SP-11 REMOVE AND INSTALL RINGS - EXTRA DEPTH**

Reconstruct MH Rings (Extra Depth) - The Contractor shall be responsible for replacing rings to a depth of 18 inches from the top of casting (rim or flow line). Any rings replaced at a depth greater than 18 inches from the top of the casting (rim or flow line) shall be considered "extra depth." The Contractor shall replace all existing

rings down to the top of the structure. The thickness of each ring shall range from 2" to 12" as needed in the field. The Contractor shall match the existing diameter (24" or 27"). The Contractor shall be paid at the contract unit price per lineal foot which shall be compensation in full for all costs incidental to construction including, but not limited to, removals, excavation, rings, mortar/grout, and labor.

**SP-12 STORM BARREL SECTIONS**

Storm barrel sections for manholes and catch basins shall have a solid consistent wall thickness (precast) from the base slab to the top slab. A barrel with an exposed spigot or bell end shall not be set on a base slab, nor have a top slab set upon it.

**SP-13 CONNECT TO EXISTING STORM SEWER**

"Connect to Existing Storm Sewer," per each, shall include pipe to existing pipe, pipe to existing manhole/catch basin and manhole/catch basin to existing pipe. Payment for connect items shall be at the contract unit price as listed on the Bid Form. All associated work items shall be considered incidental.

**SP-14 LOW PROFILE CASTING**

The contractor shall install low profile castings for manholes and catch basins where determined by the Engineer. Contractor shall stock several on the project and have readily available. If the Engineer directs the Contractor to replace a salvaged casting with a new low profile casting, there will be no additional compensation for delivery of the casting as it should be available on the project. Salvaged casting shall then become the property of the City. There will be no additional compensation beyond the unit bid price for furnishing and installing the casting.

**SP-15 AGGREGATE BASE, CLASS 7, FULL DEPTH RECYCLED PRODUCTION**

The proposed street aggregate base shall be reconstructed using full depth aggregate base recycling method. The Contractor shall produce reclaimed aggregate base material by pulverizing together the existing bituminous and gravel base utilizing a machine (cold) process to provide a blended aggregate mixture.

**Reclaiming operations shall produce an aggregate material meeting Mn/DOT 3138, Class 7 specifications. Excessive, visible, oversize particles greater than 3 inches shall be removed by the Contractor either by hand or mechanically.** Areas may be required to be reclaimed a second time to pulverize oversized particles as determined by the Engineer. The Contractor is responsible to protect Aggregate Base, Class 7, Full Depth Recycled Production from contamination during all phases of reconstruction.

The Contractor shall remove excess reclaim material, grade, shape and compact in preparation of placing the pavement surfacing. The subgrade shall be shaped to allow placing of the proposed pavement sections shown on the plans. Water shall be applied to stabilize the base as needed and is considered incidental to the project.

Aggregate Base, Class 7, Full Depth Recycled Production shall include all labor and equipment to reclaim the existing bituminous and aggregate/granular base in a single operation in place. The depth of reclamation shall vary between 8" to 12" as directed by the Engineer. Please refer to the soil exploration report for pavement thickness for the streets on the project.

The Contractor shall be paid the unit bid price for reclaiming to a depth of 12.0" inches. In the event the Contractor reclaims greater than 12.0", the Contractor will be entitled to additional payment as approved by the Engineer. Payment shall be determined by prorating the additional reclaiming by dividing the depth by



12.0". For example, if the reclaim is found to be 12" deep, the Contractor will receive compensation equivalent of 14" / 12" of the unit bid price for full depth reclaiming for that area measured in the field by the Engineer.

This pay item shall include all labor and equipment for pulverizing, blending, shaping, and compacting operations necessary to provide a smooth, passable travel surface until aggregate base preparation begins. This work shall be considered a single operation. All associated work items shall be considered incidental.

The Contractor shall place the new bituminous pavement on the reclaimed surface within 10 calendar days of reclaiming. Contractor is responsible to maintain the granular surface until paving which includes shaping, erosion, and dust control. **The Contractor shall phase the project to accommodate the required paving schedule acceptable to the Engineer.**

#### **SP-16 AGGREGATE BASE PREPERATION**

The Contractor shall grade, shape, and compact the aggregate base immediately after pavement removal. This work applies to those streets where the pavement has been milled (removed) to the aggregate surface or where the pavement has been reclaimed. The Contractor shall grade to the elevation as shown in the typical sections and shape a crown such that the minimum slope is 2.0% and the maximum slope is 2.5%. The Engineer may make minor slope adjustments in the field without additional compensation to the Contractor. The Contractor shall provide a consistent slope from curb to centerline.

Aggregate base preparation will be measured by length along the centerline of the roadway work and paid for at the contract unit price per road station for the full width from curb to curb.

#### **SP-17 EXCESS RECLAIM DISPOSAL**

Excess reclaim is defined as the quantity of reclaimed material requiring to be removed in order to place the planned pavement section. The quantity of excess reclaim material shall be hauled off-site and measured by surface area reclaimed. The Contractor shall remove, haul, and dispose excess reclaim off-site. The Contractor is responsible for determining the volume of reclaim to dispose of. The Contractor shall schedule grading and hauling such that streets with the most excess material shall be last to allow use on streets with minimal or deficient cross section. Streets with crown less than 2.0% shall be built up to using excess reclaim in order to maintain 2.0% minimum unless otherwise directed by the Engineer without any additional compensation.

The Contractor will be allowed to use the excess reclaim to increase the slope of the crown to a maximum of 2.5% to minimize export hauling.

If the Engineer maintains excess material on-site rather than exporting, the work required to load, haul, and dump will be considered incidental to the aggregate base preparation bid item **but** will receive planned quantity compensation for excess reclaim disposal. The Contractor shall be compensated for spreading and compaction of the moved material on a time rate basis. If any shaping of the material to grade is required, it shall be included as part of Aggregate Base Preparation unit bid item and no additional compensation will be paid. Some examples of this use would be to replace subcut materials found undesirable in the roadbed, increase cross-slope for drainage purposes and use as backfill for utility work.

#### **SP-18 CONTRACTOR TRUCK TRAFFIC ALLOWED ON NEW PAVEMENT (DAY OF PAVING)**

On the day of paving, the Contractor will be allowed to drive loaded and unloaded delivery trucks on new pavement in order to expedite paving operations if the following criteria are met: Pavement to be driven upon has been finish rolled and;

- A designated person shall coordinate and direct asphalt delivery trucks and;
- There is no evidence of rutting, displacement or shearing of the new pavement from the delivery trucks.

**SP-19 EDGE MILL BITUMINOUS**

Prior to placement of any bituminous course, the Contractor shall mill all adjacent existing bituminous to provide a 2 inch vertical butt joint. **The Contractor shall schedule edge milling on the day of paving.** The edge shall remain vertical and protected against vehicular traffic. **A designated person or the non-equipment operating foreman shall monitor and maintain the vertical butt joint.** If the contract does not include a separate item for edge milling bituminous, then all edge milling shall be considered incidental to the other items of the contract.

**SP-20 REMOVE & REPLACE PAVEMENT (UTILITY, STREET, AND/OR CURB PATCHING)**

Pavement areas requiring removal due to utility work, curb replacement, or base deterioration (repair) shall be patched with existing type and depth of material using MnDOT SPWEA340R bituminous wearing course mixture or MnDOT 2461.2 Concrete, and 8 inches of aggregate class 5 or 7. Excess reclaim material may be used in lieu of imported aggregate upon approval by the Engineer. Contractor shall grade and mechanically compact aggregate base prior to placement of bituminous. Bituminous material shall be placed in 2 even lifts.

Payment for this item includes removals, excavation, preparation, and installation including all labor, equipment and materials to perform the work.

**SP-21 REMOVE & REPLACE DRIVEWAY PAVEMENT**

Driveways requiring removal due to utility work, curb replacement, or base deterioration (repair) shall be replaced with existing type and depth of material using MnDOT SP9.5 Wear Course SPWEA340B bituminous mixture or MnDOT Concrete Mix Design 3F52, and base material consisting of 6 inches of aggregate class 5 or 7. Excess reclaim material may be used in lieu of imported aggregate upon approval by the Engineer. Contractor shall grade and mechanically compact aggregate base prior to placement of bituminous. Bituminous material shall be placed in two even lifts. All existing pavements will be saw cut or removed to the nearest existing joint as directed by the Engineer. All saw cutting and disposal of material will be incidental to the removal pay item.

Payment for this item to include preparation, base aggregate, placement of material and all labor.

**SP-22 WALKS (ST-14)**

Walks shall be constructed in accordance with the Provisions of 2521 except as modified as follows.

Concrete Walk shall be measured per square-foot, shall include all labor and equipment for removal, disposal, and preparation of subgrade, as directed by the Engineer. Walk (pedestrian area) within 4' of the back of curb and within the turning radius shall be thickened to a minimum of 6" to withstand vehicle weight. The extra thickness shall be transitioned over a distance of approximately 8". Bid price shall also include furnishing, placement and compaction of 4-inch granular material for concrete walks shall be considered incidental.

It shall be the Contractor's responsibility and expense to provide temporary access and/or detour, as required by the Engineer.

**SP-23 CURB REPLACEMENT**

The Engineer shall identify and mark deficient curb throughout the project for replacement. Curb replacement locations are not identified on the plans but marked in the field prior to construction. The Contractor shall remove and install curbing as marked. The Contractor shall restore all disturbed areas affected by the curb replacement.

**SP-24 CONCRETE GUARANTEE AND WARRANTY**

The Contractor shall be responsible for any defects in concrete curb and gutter, concrete V-gutter, concrete driveways, and concrete tri-sections for a period of 2 years from the date of final payment authorization to the contractor by the City Council. Upon notice from the City, the Contractor shall replace any concrete that has failed including cracking, spalling (maximum of 10 pop outs per square yard), or any other deterioration that is not acceptable to the City. Any concrete replaced shall be the responsibility of the Contractor and said concrete shall be guaranteed for an additional two years from the date of this replacement and shall continue until the concrete is acceptable after a 2 year period. The Contractor shall bear all expenses to replace unacceptable work including restoration.

**SP-25 TESTING**

Any testing not identified to be the responsibility of the Contractor shall be performed by an independent testing company under separate contract with the City. The Engineer shall coordinate and order tests to be performed. The Engineer may notify the Contractor as to the requested testing schedule so the Contractor may be present to observe test method and location.

**SP-26 WATER**

Water used in conjunction with compaction of the roadbed prior to actual mixing, or water used in conjunction with actual mixing, and placing of the material shall be considered incidental to the project, and no compensation shall be paid unless a bid item is identified for this work.

Water used in conjunction with dust control shall be considered incidental to the project and no compensation shall be paid. The contractor shall sprinkle all disturbed areas to control dust as directed by the Field Inspector. The Contractor shall be available and prepared at all times, including weekends and holidays to sprinkle for dust control if deemed necessary by the Field Inspector. Water shall be applied within three hours of Engineer's direction.

A predetermined metered hydrant will be designated, and there will be no charge for water used. Each street section under construction shall be watered on a daily basis as directed by the Engineer.

**SP-27 IRRIGATION SYSTEM**

Any sprinkler heads and/or irrigation piping disturbed during construction shall be repaired and relocated by the contractor. The irrigation systems shall be repaired to as good or better condition with equal or better components as determined by the Engineer. The repair by the Contractor shall be their qualified representative with significant irrigation repair experience. The Contractor shall remove, cap, reconnect, re-install, locate parts, and other work necessary to make all sprinkler zones operable the day of disturbance or damage. If the irrigation system is inoperable beyond the next calendar day, the City or property may hire an irrigation contractor to restore operation of the system. Permanent restoration to all components of the irrigation system shall be completed within 7 calendar days of initial system disturbance. If the system is not restored within 7 calendar days, the City or owner may complete restoration. The Contractor shall reimburse

the City or property owner for all costs for temporary repair and final restoration plus 10% administration costs. This item is considered incidental to the project with no additional compensation.

**SP-28      PET FENCE**

Any pet fence or containment system disturbed during construction shall be repaired and relocated by the Contractor immediately. The Contractor shall notify the property owner and Engineer that the pet fence wire has been disturbed and possibly damaged. The pet fence systems shall be repaired to as good or better condition. The repair shall be made by the Contractor or his/her qualified representative within 24 hours of disturbance. If the pet fencing is inoperable beyond the 24 hours allowed, the City or property owner may hire a pet fence contractor to restore operation of the fence. All costs for restoration shall be reimbursed by the Contractor to the City plus 10% administration costs. This item is considered incidental to the project with no additional compensation.

**SP-29      SILT FENCE**

Silt fence shall be installed at locations designated by the Engineer if. Silt fence shall conform to the requirements of MnDOT Specification 3886 for preassembled silt fence and shall be installed per the requirements of MnDOT Specification 2573.

**SP-30      ROCK CHECK DAM**

Rock check dams shall meet the requirements of MnDOT 3889 as amended. Rock shall be placed at a 45 degree angle along the proposed curb line within 24 hours after bituminous pavement surface has been removed. The dimensions shall be approximately 0.50 feet high, 2 feet wide and extend 4 feet towards centerline (see detail in plans). Material shall be 1 1/2 inches to 3 inches clear rock. The Contractor shall inspect rock check dams after each rain event and provide maintenance such as silt removal. Rock check dams shall be disposed and replaced when they no longer function as determined by the Engineer.

Payment for the rock check dam shall be per the bid item and include furnish, installing, removal and disposal of rock.

**SP-31      DEBRIS**

The Contractor shall remove any debris from the street on a daily basis. If construction debris is not removed from the street daily, the City will have the right to have the debris removed and charge the Contractor overtime rates. All debris material shall be removed from the City limits and disposed at a qualified dump or recycling site.

**SP-32      STREET SWEEPING**

The Contractor shall be required to sweep the streets prior to project acceptance as determined by the Engineer. Any adjacent streets impacted by the construction shall also be swept as deemed necessary by the Engineer. Street sweeping and surface cleanup is incidental to the contract.

**SP-33      RAIN GARDEN AND SWALES**

The Contractor shall excavate the rain garden and swales as shown in the details. Final depth and dimensions will be determined in the field by the Engineer. The Contractor shall be paid for excavation, hauling, disposal, and fine grading, per the unit bid price. During the project, additional rain gardens and swales may be added and paid at the unit bid price.

The Contractor shall over excavate such that the appropriate materials such as topsoil, compost and mulch can be placed to proper grade. Compost and mulch shall be installed by others. The Engineer may require the Contractor to furnish and install 4" select topsoil and seeding in swale areas. The Contractor shall be paid at the unit bid prices.

**SP-34 SELECT TOPSOIL BORROW (ST-17)**

Topsoil provided by the Contractor for landscaping purposes shall meet the requirements of MnDOT Specifications 3877.2B. In addition, topsoil shall be pulverized and free from heavy clay, coarse sand, stones, plants, roots, sticks and other foreign materials. The bid item for "Select Topsoil Borrow" shall include all costs associated with furnishing and spreading the Select Topsoil Borrow material. Any testing requested by the City shall be performed by a City approved testing company or agency. This test shall be paid for by the contractor.

**SP-35 SEED, FERTILIZER & HYDRAULIC SOIL STABILIZER**

Controlling erosion and establishing vegetation shall be performed in accordance with the provisions of Mn/DOT 2575, except as modified below:

Seed mix, fertilizer and hydraulic soil stabilizer shall be provided by the Contractor for landscape restoration purposes as needed (typically behind curb or hydrant replacement). The bid item for "Seed, Fertilizer & Hydraulic Soil Stabilizer" shall include all costs associated with furnishing, installing and establishing growth. Any testing requested by the City shall be performed by a City approved testing company or agency.

The Contractor shall maintain (including watering) for a minimum of 45 days after installation. After 45 days has passed, the Engineer and Contractor shall review the turf establishment to ensure compliance with the Contract prior to acceptance. Acceptance of areas will be made by the Engineer when it is evident that the seed placed has germinated and established an adequate protective cover. Upon acceptance, the Contractor is relieved of any further maintenance. Unaccepted areas shall be corrected at no expense to the Contractor. The Contractor shall be given one opportunity to perform corrections. If corrections are deemed unacceptable by the Engineer, the City shall order work corrected by a third party. The Contractor shall reimburse the City or accept a reduction in Contract payment for the non-performing correction costs by the third party including a ten percent (10%) administration fee.

Water is available at no cost to the Contractor per **SP-26 WATER**.

If the Engineer determines weed growth is unacceptable, the Contractor shall propose correction (with performance specifications) at no cost to the City for consideration. The correction shall perform as prescribed to the Engineer or City shall have work corrected by third party. The Contractor shall reimburse the City or accept a reduction in Contract payment for the non-performing correction costs by the third party including a ten percent (10%) administration fee.

This contract item shall meet the following specifications:

Seed, Mixture 25-151	120 lb/ac
Fertilizer Type 3 (22-5-10)	350 lb/ac
Hydraulic Soil Stabilizer Type 5 or 6	2,100 lb/ac

The Contractor may propose an alternate method of turf establishment to the Engineer for consideration. The alternate method may be considered by the Engineer but without additional cost.

**SP-36 RIGHT-OF-WAY PERMITS**

The Contractor may be required to obtain right-of-way permits from Anoka County and MnDOT. Any and all cost relating to these permits shall be considered incidental to the project. If the City has previously attained these permits, they shall be transferred to the Contractor.

**SP-37 NPDES PERMIT**

**The Contractor shall complete and submit the permit along with the fee as required.** Transfer of responsibility for the NPDES Permit will be performed by the Contractor following Award of Contract by the City.

**SP-38 POLICE OFFICER**

The City will make available a Fridley police officer during the project upon request. The officer shall be provided in order to safely provide for traffic as determined by the Engineer. The officers will be uniformed and fully equipped with a police car. The Contractor is responsible to coordinate with the Police Department. The Contractor shall provide 96 hours notice to the Police Department. Up to 16 hours are available. If a police officer is needed in excess of 16 hours, the Contractor shall reimburse the City as a rate of \$70 per hour. Payment shall be compensation for the cost of the officer and include police car, traffic control equipment, administration, and other overhead.

**SP-39 DEWATERING**

The Contractor shall provide any and all dewatering required to complete all water and sewer work on the project. Soil boring report is included with the Contract but the Bidders shall be allowed to perform additional subsurface exploration prior to bid opening.

**SP-40 BACKFLUSH WATER SERVICE**

The Contractor shall back flush all services for a minimum of 3 minutes prior to making any water service connections. The Contractor is responsible to provide temporary potable water to the building to allow for the required flushing. The Contractor shall ensure there is no damage to existing plumbing or fixtures. This work shall be considered as part of the water service connection unit bid price and without any additional compensation.

**SP-41 AGGREGATE BASE PREPARATION AND WATER TRUCK (ST-13.2)**

Reclaimed base preparation and test rolling will be measured by length along the centerline of the road bed and paid for at the contract unit price per road station which shall be compensation in full for all costs incidental to construction.

All water used for base preparation and turf establishment shall be available to the Contractor at no cost. A specific hydrant will be identified by the Water Supervisor for filling purposes. The Contractor will also be required to rent a meter from the Building Department to track usage.

**SP-42 WEEKLY CONSTRUCTION MEETING**

A weekly meeting shall be held at the Fridley Municipal Center or Public Works Garage immediately after construction activities commence. The Contractor will be required, prior to each meeting, to provide a list of activities completed, list of activities anticipated and dates of activities planned for the coming week. Meetings will be held until the punch list is complete and approved by the Engineer. Location, date and time of meeting shall be established at the Pre-Construction Meeting.

**SECTION 2-C**

**GENERAL UTILITY SPECIFICATIONS**

**Section 2 - C General Utility Construction Specifications – Table of Contents**

C-1 GENERAL.....2

C-2 SCOPE - UTILITY INSTALLATION AND SITE MAINTENANCE .....2

C-3 PIPE ALIGNMENT AND GRADE .....2

C-4 TYPE, SIZE AND CLASS OF PIPE .....2

C-5 CLASS OF BEDDING.....2

C-6 CLEANING PIPE .....2

C-7 UNSUITABLE CONDITIONS FOR LAYING PIPE .....3

C-8 CUTTING PIPE .....3

C-9 INTERRUPTION OF WATER SERVICE .....3

C-10 MAILBOX RESTORATION.....3

C-11 MAINTENANCE OF STREETS, WALKS, AND TRAILS UNTIL SURFACED .....4

C-12 CLEANING UP.....4

C-14 OVERHEAD UTILITIES AND OBSTRUCTIONS .....4

C-15 GENERAL EXCAVATION AND BACKFILL.....4

C-16 EXCAVATION.....5

C-17 BACKFILLING .....6



## **SECTION C - GENERAL UTILITY CONSTRUCTION SPECIFICATIONS**

### **C-1 GENERAL**

All surfaces disturbed during the construction period, whether caused by actual excavation, disposition of excavated material or by the construction equipment, shall be returned to its original condition or better. Exceptions to the above, if any, or special instructions pertaining to any particular action of the project will be outlined in the "Special Provisions". Any excess dirt removal shall be the responsibility of the Contractor.

### **C-2 SCOPE - UTILITY INSTALLATION AND SITE MAINTENANCE**

The Contractor shall, unless specified otherwise, furnish all materials, equipment, tools and labor necessary to do the work required under this contract and unload, haul and distribute all pipe, castings, fittings, manholes and accessories.

The Contractor shall also remove any street surfacing as required; excavate the trenches and pits to the required dimensions; construct and maintain all bridges for traffic control; sheet, brace and support the adjoining ground or structures where necessary; handle all drainage or ground water; provide barricades, guards and warning lights; lay and test the pipe casting, fittings, manholes and accessories; backfill and consolidate the trenches and pits; maintain the street or other surface over the trench until surface restoration; restore the roadway surface unless otherwise stipulated; remove surplus excavated material; and clean the site of the work.

The Contractor shall also furnish all equipment, tools, labor and materials required to rearrange sewers, conduits, ducts, pipes or other structures encountered in the installation of the work. All the above work to completely construct the street, water main, sanitary sewer, and storm sewer facilities shall be done in strict accordance with the plans and specifications.

Pipe and other accessories shall, unless otherwise directed in the Special Provisions, be unloaded at the point of delivery, hauled to and distributed at the site of the project by the Contractor. The material shall at all times be handled with care to avoid damage. In distributing the material at the site, each piece shall be unloaded opposite or near the place where it is to be laid in the trench. Pipe shall be so handled that the coating and lining will not be damaged. If, however, any part of the lining or coating is damaged, the repair shall be made by the Contractor at his expense in a manner satisfactory to the Engineer.

### **C-3 PIPE ALIGNMENT AND GRADE**

All pipes shall be laid and maintained to the required lines and grades, with manholes and fittings at the required locations. The Engineer will furnish one set of line and grade stakes necessary for the work. It shall be the Contractor's responsibility to preserve these stakes from loss or displacement. The Engineer may order replacement stakes he deems necessary for the proper execution of the work. Any replacements shall be at the Contractor's expense. All pipes shall be laid to the grade shown on the contract drawings.

### **C-4 TYPE, SIZE AND CLASS OF PIPE**

The type, size and class of pipe installed shall be in conformance with that specified or as shown on the contract drawings.

### **C-5 CLASS OF BEDDING**

The class of bedding shall be in conformance with that specified.

### **C-6 CLEANING PIPE**

All foreign matter or dirt shall be removed from the inside of the pipe before it is lowered into its position in the trench and it shall be kept clean by approved means during and after laying. The outside of the tongue or spigot end of the pipe shall be wire brushed and wiped clean and dry and free from oil and grease before the pipe is laid.

### **C-7 UNSUITABLE CONDITIONS FOR LAYING PIPE**

No pipe shall be laid in water or on an unstable base. Dewatering measures shall be taken to dry up the trench before any pipe is laid. In the event of an unstable soil condition, the unsuitable material shall be removed and replaced with a compactable material to provide a solid bearing for the water pipe. Dewatering costs are incidental to the project.

### **C-8 CUTTING PIPE**

Untapered spigot ends may be encountered when pipes are cut in the field. Before assembly, the cut ends should be beveled with a heavy file or other suitable apparatus, removing any sharp or rough edges to protect the gasket from injury and ensure ease of assembly.

### **C-9 INTERRUPTION OF WATER SERVICE**

No valve or other control on the existing system shall be operated by the Contractor, for any purpose, without approval of the Engineer. The Contractor shall, in cooperation with the Engineer, establish a schedule for shutting down the existing water system, or any portion thereof, with the City Water Department. The City Water Department shall be notified a minimum of 36 hours before any water is shut off and be advised of the probable time when service will be restored. The Contractor will then notify the affected consumers at least one hour before the service interruption and advise them of the probable length of service interruption.

### **C-10 MAILBOX RESTORATION**

A. Prior to proceeding with any work, mailboxes (including posts and cross members) so designated by Engineer shall be removed and placed on the homeowner's property. (Homeowner is responsible for the storage of their own postal box during construction.)

B. Temporary mailbox banks shall be utilized in accordance with the following:

1. Temporary mailbox banks shall be accessible to postal service and postal recipient at all times.

2. Numerous mailbox banks may be utilized to minimize distances from postal recipients.

3. Materials used to construct temporary mailbox banks shall be the Contractor's.

C. Notification of the postal service, delivery services and postal recipient shall be made 5 days prior to relocation.

D. Postal service and other affected delivery services shall approve all locations and installations.

E. If postal delivery is not achieved, work shall stop immediately and remain stopped until the situation is corrected.

F. Following construction, reinstall all mail and other delivery boxes in convenient locations and in compliance with USPS regulations.

G. Replace any box or supporting member that is damaged during construction.

H. Permanent installation shall be acceptable to the postal service, the delivery service and property owner.

**C-11 MAINTENANCE OF STREETS, WALKS, AND TRAILS UNTIL SURFACED**

After backfilling, according to the above specification, the Contractor shall maintain the street, provide stabilized material as required, and blade as necessary to provide a passable surface for traffic until the surfacing is completed or to the date of final acceptance. Class V material will be placed as ramps at all driveways to allow for access by residents until paving is complete.

**C-12 CLEANING UP**

Surplus pipe line material, tools, and temporary structures shall be removed by the Contractor and all dirt and rubbish caused by his operations and excess earth from excavations shall be hauled to a dump provided by the Contractor and approved by the Engineer and the construction site shall be left in a condition satisfactory to the Engineer.

**C-13 LANDSCAPING**

Sodding, seeding, planting and landscaping shall be in accordance with MnDOT STANDARD SPECIFICATIONS FOR CONSTRUCTION.

**C-14 OVERHEAD UTILITIES AND OBSTRUCTIONS**

Overhead utilities, poles, etc., shall be protected against damage by the Contractor and if damaged by the Contractor, shall be replaced by him at his expense.

**C-15 GENERAL EXCAVATION AND BACKFILL**

**C-15.1 SCOPE**

This section includes all excavation work required including clearing, grubbing, excavation, trenching, sheeting, shoring, dewatering, protection of adjacent property, backfilling, disposing of excess materials, grading, surface restoration and all other appurtenant work required for completion of the project.

**C-15.2 GRADING, SITE PREPARATION, LAND ALTERATION AND SITE RESTORATION**

The Contractor will be responsible for grading to within a tolerance of 0.2 foot before and after utility installation as staked by the Engineer. The site shall be completely restored to its original condition as it existed prior to construction. A soil compaction density of 100% is required after construction has been completed.

**C-15.3 EXISTING UNDERGROUND UTILITIES**

Temporary support required for adequate protection and maintenance of all private and municipal underground and service utility structures, conduits, ducts, pipes, surface and subsurface drains, sewers and other obstructions encountered in the progress of the work shall be furnished by the Contractor at his own expense under the direction of the Engineer. The Contractor shall be responsible for and shall immediately repair all damage to existing underground utilities, including house service connections to the same, which is caused by the construction work. The Contractor shall notify telephone, gas, television and electric companies and others who maintain underground utilities, sufficiently in advance of the proposed construction so that they may locate, uncover and disclose such work. Any costs incurred by the Contractor in the location of and/or the moving or protection of utilities shall be considered as incidental to the project without additional compensation to the Contractor.

Existing utilities, as shown on the plans, are based on a combination of field survey data and as-built drawings furnished by the City of the various utilities. Other utilities encountered during the progress of the work shall be treated as if they had been shown and any damage to such utilities or removal or replacement or relocation of such utilities shall be the responsibility of the Contractor.

The Engineer will cooperate with the Contractor during the course of the construction to verify the existence and location of the existing facilities but the prime responsibility remains with the Contractor.

#### **C-15.4 DEVIATIONS OCCASIONED BY OTHER UTILITY STRUCTURES**

Whenever existing utility structures or branch connections leading to main sewers or to main drains, or other conduits, ducts, pipes or structures present obstructions to the grade and alignment of the pipe, they shall be permanently supported, removed, relocated, or reconstructed by the Contractor through cooperation with the owner of the utility, structure or obstruction involved. In those instances where their relocation or reconstruction is impracticable, a deviation from line and grade will be ordered and the change shall be made in the manner directed.

#### **C-15.5 DEVIATION WITH ENGINEER'S CONSENT**

No deviation shall be made from the required line or grade, except with the written consent of the Engineer.

### **C-16 EXCAVATION**

#### **C-16.1 GENERAL**

Topsoil may be stripped from the site of the excavation and piled separately for use when finished grading is done. All excavated material is to be piled out of the way of other construction work until backfilling and grading is done.

The Contractor shall be responsible for storage of excavated material required for backfill. If necessary to provide working space for his operation at the site, the Contractor shall store this excavated material off the site until such time as it may be needed for backfilling.

#### **C-16.2 EXCAVATION AND PIPE TRENCH PREPARATION**

**C-16.2.1**        **General:** Pipe trenches shall be so dug that the pipe can be laid to the alignment and depth required and shall be excavated only so far in advance of pipe laying as the Engineer shall specify. The trench shall be so braced and drained that the workmen may work therein safely and efficiently. All trenches shall be sheeted and braced or sloped to a safe angle of repose as required by the State of Minnesota and OSHA.

The discharge of any required trench dewatering pumps shall be conducted to natural drainage channels, drains or storm sewers.

**C-16.2.2**        **Trench Width and Description:** The trench width may vary with and depend upon the depth of the trench and the nature of the material to be excavated. Trenches shall only be of sufficient width to provide a free working space on each side of the conduit. Trench shall meet current OSHA standards. The Contractor shall be responsible for all additional costs of excavation, surface restoration, utility and private property protection and damaged pipe resulting from enlarging the trench for Class B and Class C bedding. The trench shall be kept free from water until the joints have been completed to the satisfaction of the Engineer.

If the sides of the trench are not vertical, the toes of the side slopes shall end one (1) foot above the top of the pipe and a vertically sided trench shall be dug from there down to subgrade.

**C-16.2.3**        **Class of Bedding:** Unless otherwise specified, the pipe bedding shall be Class C.

### **C-16.3 CORRECTING FAULTY GRADE**

Any part of the trench excavated below grade shall be corrected with approved material and thoroughly compacted without additional compensation to the Contractor.

### **C-16.4 PIPE FOUNDATION IN POOR SOIL**

When the bottom at subgrade is soft and in the opinion of the Engineer, cannot adequately support the pipe, a further depth and/or width shall be excavated and refilled to pipe foundation grade with approved material and thoroughly compacted or other approved means, such as piling, shall be adopted to assure a firm foundation for the pipe with extra compensation allowed the contractor as provided elsewhere in these specifications. The Contractor shall furnish, drive and place piling if ordered by the Engineer.

### **C-16.5 PIPE FOUNDATION ON ROCK OR OTHER INCOMPRESSIBLE FOUNDATIONS**

Where ledge rock, compact rock or gravelly soil, or other unyielding foundation material is encountered, the pipes should be bedded in accordance with the requirements of the class of bedding specified but with the following additions if Class C bedding is specified. The hard unyielding material should be excavated below the bottom of the pipe and pipe bell to a depth of at least 6 inches. The width of the excavation shall be at least five-fourths (5/4) the outside diameter of the pipe. The excavation shall be refilled with granular material as specified for Class B bedding.

### **C-16.6 SOLID ROCK EXCAVATION DEFINED**

Solid rock excavation shall include such rocks as are not decomposed, weathered or shattered and which will require blasting, barring, wedging or use of air tools for removal. Under this classification shall be included the removal of any concrete or masonry structure (except concrete pavement, curb, gutter and sidewalk) exceeding one-quarter (1/4) cubic yard in volume that may be encountered in the work.

### **C-16.7 LOOSE ROCK EXCAVATION DEFINED**

Loose rock shall include all stratified rock, lodge rock, sandstone, cemented gravel, shale and boulders not otherwise defined as solid rock, regardless of how removed.

### **C-16.8 BRACED AND SHEETED TRENCHES**

The Contractor shall adequately brace and sheet excavations wherever necessary to prevent caving or damage to nearby property or to facilitate dewatering. The cost of this temporary sheeting and bracing, whether left in place or removed, unless provided for otherwise, shall be considered as part of the excavation costs without additional compensation to the Contractor. Trench sheeting shall remain in place until the pipe has been laid, tested for defects and repaired if necessary and the earth around compacted to a depth of one foot over the top of the pipe. Sheeting, bracing, etc. placed in the "pipe zone" (that part of the trench below a distance of one foot above the top of the pipe) shall not be removed without the written permission or written order of the Engineer. The Contractor may also leave in place, at his own expense, to be embedded in the backfill of the trench any sheeting or bracing in addition to that in the "pipe zone" for the purpose of preventing injury or damage to persons, corporations or property whether public or private for which the Contractor under the terms of this contract is liable.

## **C-17 BACKFILLING**

### **C-17.1 GENERAL**

All excavating in trenches shall be backfilled to the original ground surface or to such grades as specified or shown on the plans. The backfilling shall begin as soon as practicable after the pipe has been placed. Prior to any backfilling, the excavation shall be cleaned of all trash, debris, organic material, and other undesirable material.

### **C-17.2 BACKFILL PROCEDURE AT PIPE ZONE**

**SECTION 3-PB**

**PIPE BURSTING**

**Section 3 - PB Pipe Bursting Using FPVC Pipe – Table of Contents**

PB-1 CONSTRUCTION REQUIREMENTS ..... 2  
PB-2 TRENCH EXCAVATION & BACKFILL/RESTORATION ..... 7  
PB-3 TRACER WIRE ..... 9  
PB-4 TEMPORARY WATER SYSTEM ..... 10

## **SECTION PB – PIPE BURSTING USING POLYVINYLCHLORIDE (FPVC) PIPE**

### **PB-1 CONSTRUCTION REQUIREMENTS**

#### ***PB-1.1 Description***

This section shall apply for the use of fusible polyvinylchloride (PVC) pipe. This section addresses the procedures to be employed for PB installation of various sizes, as identified on the drawings. This section addresses the procedures to be employed for pipe bursting existing water pipelines of various sizes using the static method, as identified on the drawings.

#### ***PB-1.2 Qualifications***

The Contractor must be an existing licensee to perform pipeline replacement operation using the pipe bursting methodology in accordance with the patent owner.

The Contractor shall be trained and certified by the respective manufacturer of the pipe bursting equipment being used on the Project. The Contractor shall provide certification from the manufacturer that the Contractor has been trained and is proficient in the use of the equipment. Only the Contractor's employees trained and certified by the manufacturer shall be allowed to operate the equipment during the Project.

The Contractor must have successfully completed 5,000 feet of pipe bursting which includes one static pipe bursting project. Contractor shall submit a list of these projects including the owner, engineer, addresses, phone numbers and dates of projects competed with their proposal.

#### ***PB-1.3 Methods***

The Contractor shall be licensed to use the required technology proposed for this work at the time of the bid opening. Bids submitted by unlicensed Contractors will be considered non-responsive and rejected.

The method and equipment approved for rehabilitation of existing water main by pipe bursting and installation of new polyethylene pipe include:

- 1) TT Technologies, Inc GRUNDOBURST system (800.533.2078)
- 2) Earth Tool Company LLC, HAMMERHEAD HYDROBURST system (800.331.6653)
- 3) Approved or Equal.

#### ***PB-1.4 Pipe Materials***

All fusible PVC pipe shall be manufactured in the U.S.A. Approved manufacturers are:

1. Underground Solutions, Inc. (801-699-2804) Fusible C-900® and FPVC™
2. Or approved equal.



The pipe shall be sufficient in diameter and thickness to renew the required flow capacity and pressure. The pipe shall be of virgin materials and be homogenous throughout, and shall be free of visible cracks, holes, foreign material, blisters, or other deleterious faults. Pipe shall conform to the following dimensionality and general characteristics:

1. Pipe size per Special Provisions and Plans
2. Pipe color shall be blue or another color with a blue stripe as approved by the Engineer.
3. Pressure class of 165 psi

Fusible polyvinylchloride pipe shall be tested at the extrusion facility for properties required to meet all applicable parameters as outlined in either AWWA C900, applicable sections of ASTM D2241, ASTM D3034, or ASTM F679. Testing priority shall be in conformance with AWWA C900 except for pipe made to the ASTM D3034 or ASTM F679 standards, which shall be tested to those standards. All piping shall be made from a PVC compound conforming to cell classification 12454 per ASTM D1784.

The following specifications shall apply:

Reference Title

ANSI/AWWA C110/A21.10 American National Standard for Ductile-Iron and Gray-Iron Fittings, 3-inch through 48-inch, for Water and Other Liquids

ANSI/AWWA C111/A21.11 American National Standard for Rubber-Gasket Joints for Ductile-Iron Pressure Pipe and Fittings

AWWA C605-94 Standard for Underground Installation of Polyvinyl Chloride (PVC) Pressure Pipe and Fittings for Water

AWWA C651 Standard for Disinfecting Water Mains

AWWA C900-97 Standard for Polyvinyl Chloride (PVC) Pressure Pipe and Fabricated Fittings, 4 in. through 12 in. (100mm through 300mm), for Water Distribution

AWWA M23 AWWA Manual of Supply Practices PVC Pipe—Design and Installation, Second Edition

ASTM C923 Standard Specification for Resilient Connectors Between Reinforced Concrete Manhole Structures, Pipes and Laterals

ASTM D1784 Rigid Poly (Vinyl Chloride) (PVC) Compounds and Chlorinated Poly (Vinyl Chloride) (CPVC) Compounds

ASTM D1785 Poly (Vinyl Chloride) (PVC) Plastic Pipe, Schedules 40, 80, and 120

ASTM D2152 Test Method for Degree of Fusion of Extruded Poly(Vinyl Chloride) (PVC) Pipe and Molded Fittings by Acetone Immersion

- ASTM D2241 Poly (Vinyl Chloride) (PVC) Plastic Pipe (SDR PR)
- ASTM D2665 Poly (Vinyl Chloride) (PVC) Plastic Drain, Waste, and Vent Pipe and Fittings
- ASTM F477 Elastomeric Seals (Gaskets) for Joining Plastic Pipe
- ASTM F1057 Standard Practice for Estimating the Quality of Extruded Poly (Vinyl Chloride) (PVC) Pipe by the Heat Reversion Technique
- ASTM F1417 Standard Test Method for Installation Acceptance of Plastic Gravity Sewer Lines Using Low-Pressure Air
- UNI-PUB-08 Tapping Guide for PVC Pressure Pipe
- NSF-14 Plastics Piping System Components and Related Materials
- NSF-61 Drinking Water System Components--Health Effects
- PPI TR-2 PVC Range Composition Listing of Qualified Ingredients

Fusible polyvinylchloride pipe shall be tested at the extrusion facility for properties required to meet all applicable parameters as outlined in either AWWA C900, applicable sections of ASTM D2241, ASTM D3034, or ASTM F679. Testing priority shall be in conformance with AWWA C900 except for pipe made to the ASTM D3034 or ASTM F679 standards, which shall be tested to those standards. All piping shall be made from a PVC compound conforming to cell classification 12454 per ASTM D1784. Molded fittings shall be manufactured, sized, marked and be of the same manufacturer as the pipe. Pipe and fittings from different Approved Manufactures shall not be interchanged.

Pipe shall meet the following requirements:

1. Pipe shall be blue in color or black pipe with markings that follow ASTM F714 and be legibly marked in blue to identify as potable water pipe.
2. Fusible polyvinylchloride pipe shall conform to AWWA C900 and/or ASTM D2241 or ASTM D1785 for IPS standard dimensions if applicable. Testing shall be in accordance with AWWA standards for all pipe types.
3. Rework material shall be allowed per AWWA C900 standards.
4. Fusible polyvinylchloride pipe shall be extruded with plain ends. The ends shall be square to the pipe and free of any bevel or chamfer. There shall be no bell or gasket of any kind incorporated into the pipe.
5. Fusible polyvinylchloride pipe shall be manufactured in a minimum length of 20 feet.
6. Fusible polyvinylchloride pipe shall be blue in color for potable water use.
7. Pipe generally shall be marked per AWWA C900 and shall include as a minimum:

- a. Nominal pipe size
  - b. PVC
  - c. Dimension Ratio, Standard Dimension Ratio or Schedule
  - d. AWWA pressure class or standard pressure rating for non-AWWA pipe
  - e. AWWA Standard designation number or pipe type for non-AWWA pipe
  - f. NSF-61 mark verifying suitability for potable water service
  - g. Extrusion production-record code
  - h. Trademark or trade name
  - i. Cell Classification 12454 and/or PVC material code 1120 may also be included
8. Pipe shall be homogeneous throughout and be free of visible cracks, holes, foreign material, blisters, or other visible deleterious faults.
9. FUSION JOINTS
- a. Unless otherwise specified, fusible polyvinylchloride pipe lengths shall be assembled in the field with butt-fused joints. The Contractor shall follow the pipe supplier's written guidelines for this procedure. All fusion joints shall be completed as described in this specification.
10. CONNECTIONS AND FITTINGS FOR PRESSURE APPLICATIONS
11. Connections shall be defined in conjunction with the coupling of project piping, as well as the tie-ins to other piping systems.
12. DUCTILE IRON MECHANICAL AND FLANGED FITTINGS
- a. Acceptable fittings for use with fusible polyvinylchloride pipe shall include standard ductile iron fittings conforming to AWWA/ANSI C110/A21.10 and AWWA/ANSI C111/A21.11.
  - b. Connections to fusible polyvinylchloride pipe may be made using a restrained or non-restrained retainer gland product for PVC pipe, as well as for MJ or flanged fittings.
  - c. Bends, tees and other ductile iron fittings shall be restrained with the use of thrust blocking or other means as indicated in the construction documents.
  - d. Ductile iron fittings and glands must be installed per the manufacturer's guidelines.

13. PVC GASKETED, PUSH-ON FITTINGS

- a. Acceptable fittings for use with fusible polyvinylchloride pipe shall include standard PVC pressure fittings conforming to AWWA C900.
- b. Acceptable fittings for use joining fusible polyvinylchloride pipe other sections of fusible polyvinylchloride pipe or other sections of PVC pipe shall include gasketed PVC, push-on type couplings and fittings, including bends, tees, and couplings as shown in the drawings.
- c. Bends, tees and other PVC fittings shall be restrained with the use of thrust blocking or other restraint products as indicated in the construction documents.
- d. PVC gasketed, push-on fittings and mechanical restraints, if used, must be installed per the manufacturer's guidelines.

14. FUSIBLE POLYVINYL CHLORIDE SWEEPS OR BENDS

- a. Fusible polyvinyl chloride sweeps or bends shall conform to the same sizing convention, diameter, dimensional tolerances and pressure class of the pipe that they are joining together.
- b. Fusible polyvinyl chloride sweeps or bends shall be manufactured from the same fusible polyvinyl chloride pipe being used for the installation, and shall have at least 2 feet of straight section on either end of the sweep or bend to allow for fusion of the sweep to the pipe installation.
- c. Standard fusible polyvinyl chloride sweep or bend angles shall not be greater than 22.5 degrees, and shall be used in nominal diameters ranging from 4 inch through 16 inch.

15. SLEEVE-TYPE COUPLINGS

- a. Sleeve-type mechanical couplings shall be manufactured for use with PVC pressure pipe, and may be restrained or unrestrained as indicated in the construction documents.
- b. Sleeve-type couplings shall be rated at the same or greater pressure carrying capacity as the pipe itself.

16. EXPANSION AND FLEXIBLE COUPLINGS

- a. Expansion-type mechanical couplings shall be manufactured for use with PVC pipe, and may be restrained or unrestrained as indicated in the construction documents.
- b. Expansion-type mechanical couplings shall be rated at the same or greater pressure carrying capacity as the pipe itself.

## 17. CONNECTION HARDWARE

- a. Bolts and nuts for buried service shall be made of non-corrosive, high-strength, low-alloy steel having the characteristics specified in ANSI/AWWA C111/A21.11, regardless of any other protective coating.

Joint strength shall be equal to or greater than pipe strength. The Contractor shall provide a lead person with a minimum of 5 years of experience with the fusing of PVC pipe. This lead person shall perform the fusing work.

### ***PB-1.5 Equipment***

Pipe bursting tool shall be static. The bursting action of the tool shall increase the external dimensions sufficiently, causing breakage of the pipe at the same time expanding the surrounding ground. This action shall not only break the pipe, but also create the void into which the burster can be statically pulled which enables forward progress to be made. Simultaneously, the new PVC pipe, directly attached to the expander, shall also move forward.

The static pulling frame shall be telescopic in design to allow the cutting head to release at the termination of the pull. This also provides minimal trench length by telescopic adjustment. Any other method of pulling may be approved by the Engineer upon written request along with supporting information.

### ***PB-1.6 Submittals***

Submit manufacturer's specific technical data with complete information on physical properties of pipe and pipe dimensions pertinent to this job. A certificate of "Compliance with Specification" or suitable alternative shall be furnished for all materials to be supplied.

Submit complete calculations including lists of parameters, all formulas and all other data showing the design of the new pipe.

Submit detail drawings and written descriptions of the entire construction procedure to install pipe, pit sizes, pit construction and shoring, and service reconnections.

### ***PB-1.7 License Agreements***

When requested by the City, the Contractor shall submit evidence acceptable to the City, such as a certified copy of a license or agreement, that it has the authority from the patented equipment and materials. The Contractor agrees to defend, indemnify and hold harmless the City and the Engineer against all claims, suits, and actions or other damages as a result of negligence of any person or property arising out of patent infringement by the Contractor or the Contractor's employees, agents, the suppliers, or any tier of subcontractors involved in the work.

## **PB-2 TRENCH EXCAVATION & BACKFILL/RESTORATION**

***PB-2.1 Safety***

The Contractor shall carry out operations in strict accordance with all applicable OSHA Standards. Particular attention is drawn to those safety requirements involving work entry into confined spaces. It shall be the Contractor's responsibility to familiarize and its employees with OSHA Standards and regulations pertaining to all aspects of the work.

***PB-2.2 Water Service Disconnect and Reconnect Excavations***

The location and number of water service excavations shall be planned by the Contractor and submitted in writing for approval by the Engineer 10 days prior to excavation.

Before excavation is begun, it will be the responsibility of the Contractor to check with the various utility companies and determine the location of existing utilities in the vicinity of the work area. If required, the Contractor will attain temporary construction easement and/or right-of-way areas at no cost to the City.

Damage to utilities and the resulting repair, temporary service costs, etc., shall be borne by the Contractor. Access pits shall be backfilled in accordance with the appropriate specifications.

All excavations shall be properly sheeted/shored in accordance with relevant specifications for trench safety systems. Any damage resulting from improperly shored excavations shall be corrected to the satisfaction of the Engineer with no compensation due to the Contractor. Trenches shall be excavated and shored such that traffic on University Avenue West Service shall be maintained in at least 1 direction. The Contractor may need to provide one or more flaggers.

All open excavations shall be kept secure at all times by the use of concrete barricades (Jersey Type), appropriate lighting and signing, and steel plates covers. All pits shall be backfilled prior to the weekend, thus no pits shall remain excavated between Friday night (8:00 p.m.) and Monday morning (6:00 a.m.).

All excavation pits shall be minimized within the confines of OSHA regulations. The Contractor will be responsible for surface restoration (aggregate, pavement, topsoil, and sodding) of any excavation in excess of 20 feet wide by 30 feet long, unless otherwise identified in the plans. This includes hydrant pits and service pits.

***PB-2.3 Insertion and Receiving Excavations***

The location and number of insertion and receiving excavations shall be planned by the Contractor and submitted in writing for approval by the Engineer 10 days prior to excavation.

Before excavation is begun, it will be the responsibility of the Contractor to check with the various utility companies and determine the location of existing utilities in the vicinity of the work area. If required, the Contractor will attain temporary construction easement and/or right-of-way areas at no cost to the City.

Damage to utilities and the resulting repair, temporary service costs, etc., shall be borne by the Contractor. Access pits shall be backfilled in accordance with the appropriate specifications.

All excavations shall be properly sheeted/shored in accordance with relevant specifications for trench safety systems. Any damage resulting from improperly shored excavations shall be corrected to the satisfaction of the Engineer with no compensation due to the Contractor. Trenches shall be excavated and shored such that traffic on University Avenue West Service shall be maintained in at least 1 direction. The Contractor may need to provide one or more flaggers.

All open excavations shall be kept secure at all times by the use of concrete barricades (Jersey Type), appropriate lighting and signing, and steel plates covers. All pits shall be backfilled prior to the weekend, thus no pits shall remain excavated between Friday night (8:00 p.m.) and Monday morning (6:00 a.m.).

One or more receiving pits shall be excavated at appropriate points within the length of the existing pipe. Pit shall be centered over the existing pipe.

All excavation pits shall be minimized within the confines of OSHA regulations. The Contractor will be responsible for surface restoration (aggregate, pavement, topsoil, and sodding) of any excavation in excess of 20 feet wide by 30 feet long, unless otherwise identified in the plans. This includes receiving pits and insertion pits.

The number of pits for machine and pipe insertion shall be the minimum necessary to most efficiently accomplish the work. The Contractor shall give consideration to the use of excavation required for other purposes such as for service reconnections, and valve and appurtenance locations in order to reduce the number of pits.

#### ***PB-2.4 Testing***

The Contractor shall test pipe in accordance with City specifications.

#### ***PB-2.5 Basis of Measurement and Payment***

Pipe installed by Pipe Bursting will be measured and paid for by the linear foot along the centerline installed complete and in place at the Contract unit price. This price includes all materials, equipment and labor required to complete the installation in full, including the tracer wire.

All associated work items shall be considered incidental.

### **PB-3 TRACER WIRE**

#### ***PB-3.1 Materials***

SoloShot Xtreme by Copperhead.Industries, LLC, or approved equal or approved equal.

#### ***PB-3.2 Tracer Wire Access***

All tracer wire shall be continuous and without splices from valve box to valve box, valve box to fire hydrant, or fire hydrant to fire hydrant. Tracer wire shall be secured every 18-inches to the outside of the valve box and be brought up on the outside of the valve box to a point 4-inches below grade and then brought into the valve box and left with an additional 18-inches of slack, unless otherwise recommended by the manufacturer.

***PB-3.3 Tracer Wire Testing***

All tracer areas shall be tested for continuity after the PVC pipe installation is completed.

***PB-3.4 Method of Measurement***

Payment for Tracer Wire will be incidental to the watermain pipe cost.

***PB-3.5 Basis of Payment***

Payment for Tracer Wire will be based on the linear feet (LF) placed.

**PB-4 TEMPORARY WATER SYSTEM**

***PB-4.1 Construction Requirements***

The Contractor shall furnish and install temporary water services to each home or business affected by the replacement of the existing water mains shown on the plans. Temporary water shall be provided to any building in which water service is interrupted for greater than 4 hours.

Prior to installation of any temporary water service, the Contractor shall submit to the Engineer for his review and approval, a plan showing details of connections, operations and other details that will meet this specification. The Contractor shall work directly with the city's utility personnel to coordinate all details necessary to install and maintain the temporary water connections within the effected homes.

Typically, the main temporary distribution line should be a minimum of four inches (4") diameter and the connection to each building a minimum of one inch (1") diameter and may be made at the building hose bib. Larger service may be required by some building as determined by the Engineer. An alternative connection point or an interior temporary plumbing revision may be necessary if the hose bib is plumbed downstream of an individual softening system or not available for use. In some instances, the hose bib may be fitted with a vacuum breaker/backflow preventer. In this case, an alternative connection point or temporary plumbing revision may be necessary.

The cost of rectifying these situations is the sole responsibility of the contractor at no additional payment to the bid unit price.

The pipe and fittings may be polyethylene in accordance with AWWA C901-78, or polybutylene in accordance with C902-78, or other pipe materials allowed by the local building code, or otherwise approved by the Engineer. Piping such as garden hoses is not approved. Pipe joints shall be welded, fused or joined in other methods approved by the local building code. Pipe shall be protected from interruption of service. Installation shall include protection provisions for vehicular traffic in driveways, lawn mowing or other related circumstances.

Each service connection must also include a vacuum breaker, back-flow preventer and screen installed at the building connection, unless other means are proposed by the Contractor. Any other provisions of the local building code must also be adhered to. Minimum pressure at the building connection for any temporary service is to match existing pressure within five pounds per square inch (5 p.s.i.). If needed, a pressure reducing valve shall be installed at each building connection. The temporary water service pipes must be disinfected in accordance with the water main specification prior to connection to the



**SECTION 4-PVC**

**DIRECTIONAL DRILLING USING PVC PIPE**

## Section 4 - PVC Horizontal Drilling – Table of Contents

HORIZONTAL DIRECTIONAL DRILLING USING POLYVINYLCHLORIDE (PVC) PIPE .....	2
PVC-1 GENERAL.....	2
PVC-2 LOCATION .....	2
PVC-3 SCOPE OF WORK.....	2
PVC-4 SUBMITTALS .....	2
PVC-5 QUALIFICATIONS .....	2
PVC-6 MATERIALS .....	3
PVC-7 METHOD OF PROCEDURE.....	7
PVC-8 INSTALLATION .....	8
PVC-9 PIPE ABANDONMENT .....	14
PVC-10 HEAVING.....	14
PVC-11 BACKFILLING AND RESTORATION.....	14
PVC-12 FIELD QUALITY CONTROL .....	15
PVC-13 METHODS OF MEASUREMENT AND PAYMENT.....	15

## **SECTION PVC - HORIZONTAL DIRECTIONAL DRILLING USING POLYVINYLCHLORIDE (PVC) PIPE**

### **PVC-1 GENERAL**

This section shall apply for the use of fusible polyvinylchloride (PVC) pipe. This section addresses the procedures to be employed for HDD installation of various sizes, as identified on the drawings.

### **PVC-2 LOCATION**

The HDD and PVC pipe and appurtenances to be constructed and installed under this Contract are located in the City of Fridley, Anoka County, Minnesota, as shown on the Plans and Drawings.

### **PVC-3 SCOPE OF WORK**

It is the intent of this Specification to define the acceptable methods and materials for installing storm sewer or water main by the horizontal directional drilling method and the requirements for PVC pipe installed by directional drilling or in open cut trenches.

### **PVC-4 SUBMITTALS**

#### ***PVC-4.1 Drilling Plan***

At least 7 days prior to mobilizing equipment the Contractor shall submit his detailed drilling plan to the Engineer.

The plan shall include a listing of major equipment, supervisory personnel, a description of the methods to be used, materials, surface monitoring methods, drilling fluid composition, pit locations, and limits of excavation.

The proposed plan and profile installation locations are based on alignments to accommodate existing and acquired easements, to avoid obstructions, and/or to tie into existing infrastructure. The Contractor may request changes to the proposed vertical and horizontal alignment of the installations. These changes shall be included in the drilling plan and must receive approval of the Engineer prior to construction.

#### ***PVC-4.2 As-Built Drawing***

The Contractor shall plot the actual horizontal and vertical alignment of the pilot bore at intervals not exceeding 25 feet. This interval shall be no greater than 10 feet for profile grades greater than 5%. The location of the pilot hole shall be monitored against the defined survey alignment and recorded as offsets from this line. This "as built" plan and profile shall be updated as the pilot bore is advanced and will be submitted to the Engineer upon completion.

#### ***PVC-4.3 Certifications***

All manufacturer product certifications, testing results, shop drawings, Contractor qualifications, etc. shall be submitted to the Engineer for approval prior to construction.

### **PVC-5 QUALIFICATIONS**

Only an experienced Contractor specializing in directional drilling and whose key personnel have at least three (3) years experience in this work shall perform the directional drilling and pipe installation.

Furthermore, the Contractor shall have installed directionally drilled pipe at least as large as called for in the Plans. The Contractor must have successfully completed 5,000 feet of PVC pipe installation. Contractor shall submit a list of these projects including the owner, engineer, addresses, phone numbers and dates of projects competed with their proposal.

## **PVC-6 MATERIALS**

### ***PVC-6.1 General***

Pipe Supplier shall furnish fusible polyvinylchloride pipe conforming to all standards and procedures, and meeting all testing and material properties as described in this specification. Manufacturer shall be a member in good standing of the Plastics Pipe Institute. In addition, PVC pipe and fittings shall meet the following requirements:

1. Pipe size per Special Provisions and Plans
2. Pipe color shall be blue or another color with a blue stripe as approved by the Engineer.
3. Pressure class of 165 psi.

Fusible polyvinylchloride pipe shall be tested at the extrusion facility for properties required to meet all applicable parameters as outlined in either AWWA C900 applicable sections of ASTM D2241, ASTM D3034, or ASTM F679. Testing priority shall be in conformance with AWWA C900 except for pipe made to the ASTM D3034 or ASTM F679 standards, which shall be tested to those standards. All piping shall be made from a PVC compound conforming to cell classification 12454 per ASTM D1784. The following specifications shall apply:

Reference	Title
-----------	-------

ANSI/AWWA C110/A21.10	American National Standard for Ductile-Iron and Gray-Iron Fittings, 3-inch through 48-inch, for Water and Other Liquids
-----------------------	---

ANSI/AWWA C111/A21.11	American National Standard for Rubber-Gasket Joints for Ductile-Iron Pressure Pipe and Fittings
-----------------------	---

AWWA C605-94	Standard for Underground Installation of Polyvinyl Chloride (PVC) Pressure Pipe and Fittings for Water
--------------	--

AWWA C651	Standard for Disinfecting Water Mains
-----------	---------------------------------------

AWWA C900-97	Standard for Polyvinyl Chloride (PVC) Pressure Pipe and Fabricated Fittings, 4 in. through 12 in. (100mm through 300mm), for Water Distribution
--------------	---

AWWA M23	AWWA Manual of Supply Practices PVC Pipe—Design and Installation, Second Edition
----------	--

ASTM C923	Standard Specification for Resilient Connectors Between Reinforced Concrete Manhole Structures, Pipes and Laterals
-----------	--

ASTM D1784 Rigid Poly (Vinyl Chloride) (PVC) Compounds and Chlorinated Poly (Vinyl Chloride) (CPVC) Compounds

ASTM D1785 Poly (Vinyl Chloride) (PVC) Plastic Pipe, Schedules 40, 80, and 120

ASTM D2152 Test Method for Degree of Fusion of Extruded

Poly(Vinyl Chloride) (PVC) Pipe and Molded Fittings by Acetone Immersion

ASTM D2241 Poly (Vinyl Chloride) (PVC) Plastic Pipe (SDR PR)

ASTM D2665 Poly (Vinyl Chloride) (PVC) Plastic Drain, Waste, and Vent Pipe and Fittings

ASTM D3034 Standard Specification for Type PSM Poly(Vinyl Chloride) (PVC) Sewer Pipe and Fittings

ASTM F477 Elastomeric Seals (Gaskets) for Joining Plastic Pipe

ASTM F1057 Standard Practice for Estimating the Quality of Extruded Poly (Vinyl Chloride) (PVC) Pipe by the Heat Reversion Technique

UNI-PUB-08 Tapping Guide for PVC Pressure Pipe

NSF-14 Plastics Piping System Components and Related Materials

NSF-61 Drinking Water System Components--Health Effects

PPI TR-2 PVC Range Composition Listing of Qualified Ingredients

***PVC-6.2 Piping and Fittings***

1. Fusible polyvinylchloride pipe shall conform to AWWA C900 and/or ASTM D2241 or ASTM D1785 for IPS standard dimensions if applicable. Testing shall be in accordance with AWWA standards for all pipe types.
2. Rework material shall be allowed per AWWA C900 standards.
3. Fusible polyvinylchloride pipe shall be extruded with plain ends. The ends shall be square to the pipe and free of any bevel or chamfer. There shall be no bell or gasket of any kind incorporated into the pipe.
4. Fusible polyvinylchloride pipe shall be manufactured in a minimum length of 20 feet.
5. Fusible polyvinylchloride pipe shall be blue in color for potable water use.
6. Pipe generally shall be marked per AWWA C900 and shall include as a minimum:
  - a. Nominal pipe size
  - b. PVC

- c. Dimension Ratio, Standard Dimension Ratio or Schedule
  - d. AWWA pressure class or standard pressure rating for non-AWWA pipe
  - e. AWWA Standard designation number or pipe type for non-AWWA pipe
  - f. NSF-61 mark verifying suitability for potable water service
  - g. Extrusion production-record code
  - h. Trademark or trade name
  - i. Cell Classification 12454 and/or PVC material code 1120 may also be included
7. Pipe shall be homogeneous throughout and be free of visible cracks, holes, foreign material, blisters, or other visible deleterious faults.
8. FUSION JOINTS
- j. Unless otherwise specified, fusible polyvinylchloride pipe lengths shall be assembled in the field with butt-fused joints. The Contractor shall follow the pipe supplier's written guidelines for this procedure. All fusion joints shall be completed as described in this specification.
9. CONNECTIONS AND FITTINGS FOR PRESSURE APPLICATIONS
- k. Connections shall be defined in conjunction with the coupling of project piping, as well as the tie-ins to other piping systems.
10. DUCTILE IRON MECHANICAL AND FLANGED FITTINGS
- l. Acceptable fittings for use with fusible polyvinylchloride pipe shall include standard ductile iron fittings conforming to AWWA/ANSI C110/A21.10 and AWWA/ANSI C111/A21.11.
  - m. Connections to fusible polyvinylchloride pipe may be made using a restrained or non-restrained retainer gland product for PVC pipe, as well as for MJ or flanged fittings.
  - n. Bends, tees and other ductile iron fittings shall be restrained with the use of thrust blocking or other means as indicated in the construction documents.
  - o. Ductile iron fittings and glands must be installed per the manufacturer's guidelines.
11. PVC GASKETED, PUSH-ON FITTINGS
- p. Acceptable fittings for use with fusible polyvinylchloride pipe shall include standard PVC pressure fittings conforming to AWWA C900.

- q. Acceptable fittings for use joining fusible polyvinylchloride pipe other sections of fusible polyvinylchloride pipe or other sections of PVC pipe shall include gasketed PVC, push-on type couplings and fittings, including bends, tees, and couplings as shown in the drawings.
- r. Bends, tees and other PVC fittings shall be restrained with the use of thrust blocking or other restraint products as indicated in the construction documents.
- s. PVC gasketed, push-on fittings and mechanical restraints, if used, must be installed per the manufacturer's guidelines.

12. FUSIBLE POLYVINYL CHLORIDE SWEEPS OR BENDS

- t. Fusible polyvinyl chloride sweeps or bends shall conform to the same sizing convention, diameter, dimensional tolerances and pressure class of the pipe that they are joining together.
- u. Fusible polyvinyl chloride sweeps or bends shall be manufactured from the same fusible polyvinyl chloride pipe being used for the installation, and shall have at least 2 feet of straight section on either end of the sweep or bend to allow for fusion of the sweep to the pipe installation.
- v. Standard fusible polyvinyl chloride sweep or bend angles shall not be greater than 22.5 degrees, and shall be used in nominal diameters ranging from 4 inch through 16 inch.

13. SLEEVE-TYPE COUPLINGS

- w. Sleeve-type mechanical couplings shall be manufactured for use with PVC pressure pipe, and may be restrained or unrestrained as indicated in the construction documents.
- x. Sleeve-type couplings shall be rated at the same or greater pressure carrying capacity as the pipe itself.

14. EXPANSION AND FLEXIBLE COUPLINGS

- y. Expansion-type mechanical couplings shall be manufactured for use with PVC pipe, and may be restrained or unrestrained as indicated in the construction documents.
- z. Expansion-type mechanical couplings shall be rated at the same or greater pressure carrying capacity as the pipe itself.

15. CONNECTION HARDWARE

- aa. Bolts and nuts for buried service shall be made of non-corrosive, high-strength, low-alloy steel having the characteristics specified in ANSI/AWWA C111/A21.11, regardless of any other protective coating.

PVC-6.3 MANUFACTURER

All fusible PVC pipe shall be manufactured in the U.S.A. Approved manufacturers are:

- 1. Underground Solutions, Inc. (801-699-2804) Fusible C-900® and FPVC™
- 2. Or approved equal.

**PVC-7 METHOD OF PROCEDURE**

***PVC-7.1 General***

All PVC pipe shall be cut, fabricated, and installed in strict conformance with the pipe manufacturer's recommendations. Joining, laying, and pulling of PVC pipe shall be accomplished by personnel experienced in working with PVC pipe. The pipe supplier shall certify in writing that the contractor is qualified to join, lay, and pull the pipe or a representative of the pipe manufacturer shall be on site to oversee the pipe joining. Expense for the representative shall be paid for by the contractor.

***PVC-7.2 Transportation***

The manufacturer shall package the pipe in a manner designed to deliver the pipe to the project neatly, intact, and without physical damage. Care shall be taken during transportation of the pipe to ensure that it is not cut, kinked, or otherwise damaged.

***PVC-7.3 Storage***

Pipes shall be stored on level ground, preferably turf or sand, free of sharp objects that could damage the pipe. Stacking of the PVC pipe shall be limited to a height that will not cause excessive deformation of the bottom layers of pipes under anticipated temperature conditions. Where necessary, due to ground conditions, the pipe shall be stored on wooden sleepers, spaced suitably and of such widths as not to allow deformation of the pipe at the point of contact with the sleeper or between supports.

***PVC-7.4 Handling Pipe***

The handling of the joined pipeline shall be in such a manner that the pipe is not damaged by dragging it over sharp cutting objects. Ropes, fabric, or rubber protected slings and straps shall be used when handling pipes. Chains, cables, or hooks inserted into pipe ends shall not be used. Two slings spread apart shall be used for lifting each length of pipe. Pipe or fittings shall not be dropped onto rocky or unprepared ground. Slings for handling the pipeline shall not be positioned at butt-fused joints. Sections of the pipes with cuts and gouges exceeding 10 percent of the pipe wall thickness or kinked sections shall be removed and the ends rejoined.



The open ends of all sections of joined and/or installed pipe (not in service) shall be plugged at night to prevent animals or foreign material from entering the pipeline or pipe section.

Waterproof nightcaps of approved design may be used but they shall also be so constructed that they will prevent the entrance of any type of natural precipitation into the pipe and will be fastened to the pipe in such a manner that the wind cannot blow them loose.

The practice of stuffing cloth or paper in the open ends of the pipe will be considered unacceptable.

Where possible, the pipe shall be raised and supported at a suitable distance back from the open end such that the open end will be below the level of the pipe at the point of support.

***PVC-7.5 Existing Improvements and Utilities:***

Prior to construction, the Contractor shall obtain field locates in order to determine the existence and location of private as well as public utilities which may be underground or overhead and which may be interfered with under this contract.

All existing underground, surface or overhead structures, are not necessarily shown on the Plans, and are only approximately correct. The Contractor shall satisfy himself as to the accuracy of the information given

**PVC-8 INSTALLATION**

***PVC-8.1 General***

The Contractor shall install the pipelines by means of horizontal directional drilling.

Horizontal directional drilling shall consist of the drilling of a small diameter pilot hole from one end of the alignment to the other, followed by enlarging the hole diameter for the pipeline insertion. The Contractor, subject to the requirements of these Specifications, will determine the exact method and techniques for completing the directionally drilled installation.

The required piping shall be assembled in a manner that does not obstruct adjacent roadways. The Contractor shall erect temporary fencing around the entry and exit pipe staging areas.

The Contractor shall locate his entry and exit pits as to minimize disruption of traffic, lessen disturbance to adjacent residents and to preserve existing trees, structures, pavements, private utilities, and/or public infrastructure. All open excavations shall be kept secure at all times by the use of concrete barricades (Jersey Type), appropriate lighting and signing, and steel plates covers. All pits shall be backfilled prior to the weekend, thus no pits shall remain excavated between Friday night (8:00 p.m.) and Monday morning (6:00 a.m.).

Dewatering shall be performed in a manner that will prevent sediment from being discharged into downstream receiving waters. The Contractor shall use Best Management Practices (BMPs) to ensure erosion and sediment discharge be prevented.

Topography and profiles of the ground shown on the Drawings are believed to be reasonably accurate, but are not guaranteed to be absolutely so and are presented only as an approximation.

### ***PVC-8.2 Drilling Operations***

The Contractor shall prepare a drilling plan to be submitted for Engineer approval, which describes the pilot hole drilling procedure, the reaming operation, and the pullback procedure. All drilling operations shall be performed by supervisors and personnel experienced in horizontal directional drilling. All required mud cleaning, mud disposal, and other required support systems used during this operation shall be provided by the Contractor.

Drill pipe shall be API steel drill pipe, Range 2, Premium Class or higher, Grade S-135 in a diameter sufficient for the torque and longitudinal loads and fluid capacities required for the work. Only drill pipe inspected under API's Recommended Practice Specification API RP 7G and certified as double white band, or better, shall be used.

The Contractor shall utilize machinery of modern capability that is in proper working order and that is sufficiently sized for the drilling and pullback criteria for the specific job.

No extension of time or additional compensation will be given the Contractor for delays, repairs, or damage to either the pipe being installed or surrounding elements due to limitations of the drilling machinery.

A smoothly drilled pilot hole shall follow the design centerline of the pipe profile and alignment described on the construction drawings.

Steering equipment shall be housed in a non-magnetic bottom-hole assembly of the lead section of the non-magnetic drill pipe to allow for in-hole deviation at the front during the drilling of the pilot hole.

Additional (two or more) non-magnetic drill collars shall be included and drilled behind the non-magnetic bottom-hole assembly to serve as a buffer between the pilot drill string and the steering guidance probe.

The Contractor shall at all times provide and maintain instrumentation that will accurately locate the pilot hole and measure drilling fluid flow and pressure. Deviations from the acceptable tolerances described in the Specifications shall be documented and immediately brought to the attention of the Engineer for discussion and/or approval. The profile and alignment defined on the Drawings for the bores specifies the minimum depth, slope, and radius of curvature. At no point in the drilled profile shall the radius of curvature of the bore be less than 100 feet. The Contractor shall grant the Engineer access to all data and readout pertaining to the position of the bore head and the fluid pressure and flows. The Contractor shall employ experienced personnel to operate the directional drilling equipment and, in particular, the position monitoring and steering equipment. No information pertaining to the position or inclination of the pilot bores shall be withheld from the Engineer.

If the pilot hole alignment fails to conform to specified requirements, the Contractor shall drill a new pilot hole with no additional compensation.

### ***PVC-8.3 Drilling Fluids***

A water-based mud (WBM) consisting of a bentonite/polymer mixed drilling fluid shall be injected through the drill pipe attached to the drilling auger to suspend the cuttings, thus keeping the hole filled with a slurry of bentonite and cuttings. A 50/50 ratio of drilling fluid to solids is desirable. When the drilling auger reaches the pilot drill entry point on its final reaming pass, the drilling auger shall be pushed back through the pre-reamed hole to the exit side while at the same time injecting bentonite.

Prior to installation of the pipe into the drilled tunnel, the Contractor shall notify the Engineer and inform him of the conditions encountered during the augering to determine whether a cement slurry shall be used as a supplement. If subsurface conditions contain predominately clayey soils, then the bentonite slurry shall be used. If, on the other hand, substantial pockets of granular material are encountered, then cement slurry shall be chosen by the Contractor, and approved by the Engineer, as a supplement for added strength of the tunnel.

Technical criteria for bentonite shall be as given in API Spec. 13A, Specification for Oil Well Drilling Fluids Material for fresh water drilling fluids. Any modification to the basic drilling fluid involving additives must describe the type of material to be used and be included in the Contractor's drilling plan presented to the Engineer. The Owner retains the right to sample and monitor the waste drilling mud, cuttings, and water.

The Contractor is responsible for obtaining, transporting, and storing any water required for drilling fluids.

### ***PVC-8.4 Joining Pipe Sections***

Fusion Technician shall be fully qualified by the pipe supplier to install fusible polyvinylchloride pipe of the type(s) and size(s) being used. Qualification shall be current as of the actual date of fusion performance on the project. The Contractor shall provide a lead person with a minimum of 5 years experience with the fusing of PVC pipe. This lead person shall perform the fusing work. Each length of pipe shall be inspected and cleaned as necessary to be free of debris immediately prior to joining.

Fusible polyvinylchloride pipe will be handled in a safe and non-destructive manner before, during, and after the fusion process and in accordance with this specification and pipe supplier's guidelines. Fusible polyvinylchloride pipe will be fused by qualified fusion technicians, as documented by the pipe supplier. Each fusion joint shall be recorded and logged by an electronic monitoring device (data logger) affixed to the fusion machine.

Only appropriately sized and outfitted fusion machines that have been approved by the pipe supplier shall be used for the fusion process. Fusion machines must incorporate the following properties, including the following elements:

1. HEAT PLATE - Heat plates shall be in good condition with no deep gouges or scratches. Plates shall be clean and free of any debris or contamination. Heater controls shall function properly; cord and plug shall be in good condition. The appropriately sized heat plate shall be capable of maintaining a

uniform and consistent heat profile and temperature for the size of pipe being fused, per the pipe supplier's guidelines.

2. CARRIAGE – Carriage shall travel smoothly with no binding at less than 50 psi. Jaws shall be in good condition with proper inserts for the pipe size being fused. Insert pins shall be installed with no interference to carriage travel.
3. GENERAL MACHINE - Overview of machine body shall yield no obvious defects, missing parts, or potential safety issues during fusion.
4. DATA LOGGING DEVICE - The current version of the pipe supplier's recommended and compatible software shall be used. Data logging device operations and maintenance manual shall be with the unit at all times. If fusing for extended periods of time, an independent 110V power source shall be available to extend battery life.

Other equipment specifically required for the fusion process shall include the following:

1. Pipe rollers shall be used for support of pipe to either side of the machine
2. A weather protection canopy that allows full machine motion of the heat plate, fusion assembly and carriage shall be provided for fusion in inclement and /or windy weather.
3. Fusion machine operations and maintenance manual shall be kept with the fusion machine at all times.
4. Facing blades specifically designed for cutting fusible polyvinylchloride pipe shall be used.

Each fusion joint shall be recorded and logged by an electronic monitoring device (data logger) connected to the fusion machine. The fusion data logging and joint report shall be generated by software developed specifically for the butt-fusion of thermoplastic pipe. The software shall register and/or record the parameters required by the pipe supplier and these specifications. Data not logged by the data logger shall be logged manually and be included in the Fusion Technician's joint report.

Pipes shall be joined to one another by means of thermal butt-fusion in accordance with ASTM D-3261 and/or the manufacturer's recommendations and be done so by personnel certified for this type of work. Thermoplastic pipe lengths to be joined by thermal butt-fusion shall be of the same type, grade, and class of pipe compound and supplied from the same raw material supplier. The tensile strength of the butt-fusion joints shall not be less than the pipe. Finished bead projections shall not be greater than 3/16".

Mechanical connections of the pipe to auxiliary equipment shall be through flanged connections, which shall consist of the following:

1. Provide ASTM A240, Type 304 stainless steel backing flange, 125-pounds, ANSI B16.1 standard, and gaskets as required by the manufacturer.

2. Cor-Blue T-bolts with Protecto Caps shall be used on all mechanical joints. No other type of bolts shall be allowed unless approved by the Engineer.

#### ***PVC-8.5 Tolerances***

Pipe installed by the directional drilled method must be located as shown on the drawings with a vertical alignment tolerance of 6" and a horizontal alignment shall be between 3.0' and 5.0' from the existing pipe with no tolerance outside that range, with due consideration of the position of any other entry/exit points and the existing utilities. In all cases, right-of-way or easement restrictions shall take precedence over the listed tolerances. Regardless of the tolerance achieved, no pilot hole will be accepted if it will result in any, or all, of the pipeline being installed in violation of right-of-way or easement restrictions. Alternate alignment maybe considered and approved by the Engineer upon written request by the Contractor.

The alignment of each pilot bore must be approved by the Engineer before pipe can be pulled. If the pilot bore fails to conform to the above tolerances, the Engineer may, at his option, require a new pilot boring to be made.

After the pipe is in place, cleaning pigs shall be used to remove residual water and debris. After the cleaning operation, the Contractor shall provide and run a sizing pig to check for anomalies in the form of buckles, dents, excessive out-of roundness, and any other deformations. The sizing pig run shall be considered acceptable if the results indicate that there are no sharp anomalies (e.g. dents, buckles, gouges, and internal obstructions) greater than 2 percent of the nominal pipe diameter, or excessive ovality greater than 5 percent of the nominal pipe diameter. For gauging purposes, dent locations are those defined above which occur within a span of five (5) feet or less. Pipe ovality shall be measured as the percent difference between the maximum and minimum diameters. For gauging purposes, ovality locations are those defined above which exceed a span of five (5) feet.

#### ***PVC-8.6 Ream and Pullback***

Reaming: Reaming operations shall be conducted to enlarge the pilot bore. The number and size of such reaming operations shall be conducted at the discretion of the Contractor. The desired end result of reaming is a tunnel diameter of 1.5x (times) the installed pipe diameter for pipes less than or equal to 10" and 1.3x (times) the diameter for pipes greater than 10". Any damage to the pipe resulting from inadequate pre-reaming shall be the responsibility of the Contractor.

The Contractor shall set his pullback speed as to not "outrun the mud". This is done by dividing his mud pump capacity (gpm) by the desired gallons of drilling fluid per foot to achieve the 50/50 ratio of drillings fluid to solids.

The maximum allowable pull exerted on the PVC pipelines shall be measured continuously by the Contractor and limited to the maximum allowed by the pipe manufacturer so that the pipe or joints are not over stressed.

If hydra-lock occurs during the pullback process, the Contractor must first wait to see if the condition is reversed. If waiting does not fix the hydra-lock, the Contractor, at the discretion of the Engineer, shall dig up the back reamer to relieve the pressure.

Torsion and Stresses: A swivel shall be used to connect the pipeline to the drill pipe to prevent torsional stresses from occurring in the pipe.

The lead end of the pipe shall be closed during the pullback operation.

Pipeline Support: The pipelines shall be adequately supported by rollers and side booms and monitored during installation so as to prevent overstressing or buckling during the pullback operation. Such support/rollers shall be spaced at a maximum of 60 feet on centers, and the rollers to be comprised of a non-abrasive material arranged in a manner to provide support to the bottom and bottom quarter points of the pipeline allowing for free movement of the pipeline during pullback. The Contractor shall repair surface damage before pulling operations resume.

The Contractor shall at all times handle the PVC pipe in a manner that does not over stress the pipe. Vertical and horizontal curves shall be limited so that wall stresses do not exceed 50 percent of yield stress for flexural bending of the PVC pipe. If the pipe is buckled or otherwise damaged, the damaged section shall be removed and replaced by the Contractor at his expense. The Contractor shall take appropriate steps during pullback to ensure that the PVC pipe will be installed without damage.

After pull back of the PVC pipe, the pipe shall remain in the drilled hole at least 24 hours before any connections or cutting of pipe shall be made.

#### ***PVC-8.7 Handling Drilling Fluids and Cuttings***

The HDD operation is to be conducted in a manner to eliminate the discharge of water, drilling fluids, and cuttings to any adjacent waterway or land areas involved during the construction process. The Contractor shall provide equipment and procedures to maximize the recirculation or reuse of drilling mud to minimize waste. The Contractor shall line all excavated pits used in the drilling operations with heavy-duty plastic sheeting with sealed joints to prevent the migration of drilling fluids. The Contractor shall comply with all permit provisions. After completion of the directional drilling work, the entry and exit pit locations shall be restored to original conditions.

The Contractor shall visit the site and must be aware of all structures and site limitations surrounding the directional-drilled pipeline path and provide the Engineer with a drilling plan outlining procedures to prevent drilling fluid from adversely affecting the surrounding area. As part of the drilling plan specified herein before, the Contractor shall submit a drilling fluid plan which details types of drilling fluids, cleaning and recycling equipment, estimated flow rates, and procedures for minimizing drilling fluid escape.

The general work areas on the entry and exit sides shall be enclosed by a berm to contain unplanned spills or discharges.

Equipment (graders, shovels, etc.) and materials (such as groundsheets, hay bales, booms, and absorbent pads) for cleanup and contingencies shall be provided in sufficient quantities by the Contractor and maintained on the site for use in the event of inadvertent leaks, seeps or spills.

When the Contractor's provisions for storage of the fluids or cuttings on site are exceeded, these materials shall be dewatered, dried, and stock piled such that it can be transferred to a truck and hauled off site to a suitable legal disposal site. The maximum allowed water content of these solids is 50% by weight.

#### ***PVC-8.8 Tracer Wire***

Two (2) Tracer Wires shall be laid with the PVC pipe and shall be Direct Burial #12 AWG Solid (0.0808" diameter), 21% conductivity copper-clad hard drawn high carbon steel extra high strength horizontal directional drill tracer wires, 1150 pound average tensile break load, 45 mil. The conductor insulator shall consist of a high molecular weight-high density blue polyethylene jacket complying with ASTM-D-1248, 30 volt rating. Termination of the tracer wire shall be at all clean outs. The terminations shall consist of a 2" PVC conduit attached to the cleanout for the full vertical depth of the cleanout to the surface (finish grade elevation) or other as approved by engineer.

The Contractor may also select tracer wire as defined in Section PB-3.

All tracer wire shall be tested for continuity after the installation is completed. Conductivity testing shall be performed by the contractor in the presence of the Engineer. Tracer wire and testing shall be incidental, and no direct compensation shall be made. The method of testing shall be approved by the Engineer prior to performing the test. Quantity of tracer wire shall be calculated as the length of pipe plus vertical extension to the surface. The use of 2 copper clad steel wires will count as only one wire length.

#### **PVC-9 PIPE ABANDONMENT**

In event of failure to install pipe conforming to all tolerance and test requirements of this specification, retain possession of pipe and remove it from site. The Contractor will completely fill the borehole with grout, sand or flowable fill so as to prevent future settlement at no cost to City.

If pipe cannot be withdrawn, cut pipe off at least 4 feet below ground surface, record location on drawings, and abandon pipe after filling pipe and the annular space with flowable fill.

#### **PVC-10 HEAVING**

Pavement or ground surface heave or settlement above the installation will not be permitted. To confirm if heave or settlement is occurring, the Contractor shall undertake surface monitoring as detailed on his drilling plan.

In the event that heave or settlement is detected, the Contractor shall stop the drilling operation and consult the Engineer immediately.

#### **PVC-11 BACKFILLING AND RESTORATION**

Backfilling shall be in conformance with Section C-17, "Backfilling of the General Utility Construction Specifications.

#### **PVC-12 FIELD QUALITY CONTROL**

PVC pipe installed for storm sewer use shall meet the testing requirements of sanitary as defined by CEAM specifications (1999).

Pressures test all water main pipe installed by directional drill methods in accordance with the specifications for water main and appurtenances prior to installation. All water used for hydrostatic testing purposes shall be removed from the water main upon completion of the testing purposes and be considered incidental to testing procedures.

Televise all new PVC piping installed by directional drill methods prior to disinfection. A DVD of all televised lines shall be provided to the City of Fridley prior to payment of the PVC piping.

Mandrel test all PVC piping installed by directional drill methods prior to disinfection.

Disinfect all water main piping and joints in accordance with AWWA Standard C651-99. Disinfecting of the water main lines shall be done after the pipe is televised and mandrel tested.

The form of chlorine to be used is calcium hypochlorite in either granular or pellet form.

All testing and televising procedures are considered incidental and shall be included in the unit cost of the pipe.

#### **PVC-13 METHODS OF MEASUREMENT AND PAYMENT**

Pipe installed by HDD will be measured and paid for by the linear foot along the centerline installed complete and in place at the Contract unit price. This price includes all materials, equipment and labor required to complete the installation in full, not including the tracer wire. All fittings required to connect to the existing watermain and services shall be paid as per unit bid price of lump sum. PVC fittings and transition fittings shall be considered incidental to the PVC fitting being connected to.

For installations where unknown obstructions such as boulders, concrete, and other unforeseen obstructions are encountered, and the drilling cannot be withdrawn or re-routed, and all other reasonable means to continue have failed, an excavation pit shall be allowed to investigate the obstruction. No compensation shall be given the Contractor if the obstruction cannot be classified as "Rock Excavation".



**SECTION 5-SS**

**SANITARY AND STORM SEWER CONSTRUCTION**

**Section 5 - SS Sanitary and Storm Sewer Construction Specifications – Table of Contents**

SS-1 GENERAL CONDITIONS (2621.1).....2  
SS-2 MATERIALS (2621.2) .....2  
SS-3 CONSTRUCTION REQUIREMENTS .....5  
SS-4 SEWER SERVICE INSTALLATION (2621.3C) .....5  
SS-5 MANHOLE AND CATCH BASIN STRUCTURES (2621.3D).....5  
SS-6 SANITARY SEWER LEAKAGE TESTING (2621.3E) .....6  
SS-7 RESTORATION OF SURFACE IMPROVEMENT.....6  
SS-8 INTERRUPTION OF PRIVATE WATER SUPPLIES.....6  
SS-9 METHODS OF MEASUREMENTS AND PAYMENT (2621.4 AND 2621.5)6  
SS-10 EROSION CONTROL ..... 7

**SECTION SS - SANITARY AND STORM SEWER CONSTRUCTION SPECIFICATIONS(2621)**

**SS-1 GENERAL CONDITIONS (2621.1)**

The Standard Utility Specifications for Sanitary Sewer and Storm Sewer Installation as prepared by the City Engineer's Association of Minnesota shall apply to all work and material to be furnished under this project except as modified below and Special Provisions for this project.

Copies of the Standard Utilities Specifications are available at the League of Minnesota Municipalities, 300 Hanover Blvd., St. Paul, MN 55101.

Any and all work to repair existing facilities and infrastructure shall conform to the same following specifications as for new construction and installations.

**SS-2 MATERIALS (2621.2)**

**SS-2.1 Vitrified Clay Sewer Pipe (2621.2A1)**

Vitrified clay sewer pipe may be used for sanitary sewer lines only if specified in the Special Provisions.

**SS-2.2 Ductile Iron Pipe and Fittings (2621.2A2)**

Ductile iron pipe shall be used where shown on the plans, and may be used at other locations at the Contractor’s discretion. The diameter shall be the same as that specified. Cast iron pipe shall not be used in lieu of ductile iron pipe. Ductile iron pipe shall conform to the requirements of ANSI Specification A-21.51, except the minimum design thicknesses shall be as follows:

**Pipe Metal Thickness in Inches (Class)**

Pipe Size in Inches	Depth of Cover Feet Over the Centerline of Pipe			
	0-20	20-30	30-40	40-50
4	.32=(53)	.32=(53)	.35=(54)	.38=(55)
6	.31=(52)	.31=(52)	.37=(54)	.40=(55)
8	.33=(52)	.33=(52)	.39=(54)	.42=(55)
10	.35=(52)	.38=(53)	.44=(55)	.47=(56)
12	.37=(52)	.43=(54)	.49=(56)	.49=(56)
16	.40=(52)	.49=(55)	.49=(56)	.49=(56)

Mechanical joint pipe shall comply with ASA Specifications A-21.11. Fittings shall be mechanical joint. Fittings over 12 inches in diameter shall comply with the above specifications and shall be Class 150. All pipe joints shall be approved slip type joint with rubber gasket or mechanical joint. Gaskets shall be molded styrene butadiene rubber (SBR), or nitributadine rubber (NBR) rings made expressly for the joint used.

### **SS-2.3 Reinforced Concrete Pipe and Fittings (2621.2A3)**

#### **SS-2.3.1 General**

Reinforced concrete pipe may be used for all sanitary and storm sewer pipe 12 inches in diameter or larger, only upon prior approval by the Engineer.

#### **SS-2.3.2 Fittings**

On sanitary sewers, if the connections are fabricated in the field, the hole shall be cut, not chipped, with a tapping machine and an approved saddle installed.

#### **SS-2.3.3 Jointing**

When connecting pipe with R-4 joints to an existing stub with standard bell, the connection section shall be constructed with standard spigot on one end and R-4 joint bell on the upper end.

### **SS-2.4 Corrugated Steel Pipe and Fittings (2621.2A4)**

Corrugated metal pipe may be used for storm sewer where indicated in Plans or Special Provisions. All joints shall be made with coupling bands which shall conform to the requirements of MnDOT Specification 3226.2. The band shall cover at least two full corrugations on each side of the joint. All joints shall be made soil tight by using Trumbull 5X asphalt sealer or approved equal on each side of the joint as directed.

### **SS-2.5 Polyvinyl Chloride Pipe and Fittings (2621.2A5)**

#### **Polyvinyl Chloride Pipe and Fittings**

Smooth walled polyvinyl chloride pipe and fittings shall conform to the requirements of ASTM D-3034 and ASTM F-679 for the size, standard dimension ratio (SDR), and strength requirements indicated on the Plans, Specifications, and Special Provisions. The grade used shall be resistant to aggressive soils or corrosive substances in accordance with the requirements of ASTM D-543.

Pipe fittings shall be of the same class and grade as specified for the pipe, unless otherwise specified in the special provisions. Page 43 Unless otherwise specified, all pipe and fittings shall be SDR 35 and connections shall be push-on with elastomeric gasket joints which are bonded to the inner wall of the gasket recess of the bell socket.

PVC pipe and fittings for pressure sewer and forcemains shall meet the requirements of 2611.2 A3 for watermain class pipe. Corrugated polyvinyl chloride pipe and fittings with smooth interior shall conform to the requirements of ASTM F-949 for the size and wall thickness indicated on the Plans, Specifications, and Special Provisions. Unless otherwise specified, all pipe and fittings shall be push-on with snug fit elastomeric joints meeting tightness requirements of ASTM D-3212 and ASTM F477.

### **SS-2.6 Service Pipe**

#### **SS-2.6.1 Poly Vinyl Chloride (PVC) Sewer Pipe**

PVC pipe (Schedule 40) may be used as the service pipe for gravity sewer services with a maximum cover of 25 feet, unless otherwise specified. PVC pipe (non-pressure) pipe and fittings for non-pressure gravity sewer services shall conform to the requirements of ASTM D-1784 and D-3034, and have push-on joints with elastomeric gaskets.

Nominal	Outside	Minimum Wall
4	4.215	0.162
6	6.275	0.241
8	8.400	0.323

**SS-2.6.2 Ductile Iron Service Pipe**

Ductile iron pipe may be used for sewer service pipe as approved by the Engineer.

**SS-2.7 Precast Concrete Manhole and Catch Basin Sections (2621.2C)**

Manholes shall NOT have steps, unless otherwise specified. Precast manhole joints shall be made water tight with Ram-Nek material or approved O-ring gaskets at each joint. The Ram-Nek and primer must be used in accordance with the manufacturer's instructions.

Rubber O-rings used for precast manhole joints should be the R-4 jointer or shall be designed in accordance with ASTM designation C-443. Catch basin casting shall be MnDOT casting No. 801 with grate No. 810 and curb box 823A.

Barrel sections for manholes and catch basins shall have a solid consistent wall thickness from the base slab to the top slab. A barrel with an exposed spigot or bell end shall not be set on a base slab, nor have a top slab set upon it. Storm sewer manholes shall be sized as shown on the plans.

Manhole castings shall be MnDOT 700-8. Cover shall be MnDOT casting 716 with "Sanitary Sewer" or "Storm Sewer" stamping.

The concrete base shall be Precast concrete of the size and depth shown on the plans. Concrete used for bases shall have a 28-day compressive strength of at least 4,000 pounds per square inch. .

**SS-2.8 Trash Guard**

Where shown on the plans, a trash guard shall be installed in accordance with the standard detail drawings. The trash guard shall have 5/8 inch vertical galvanized steel rods placed 6 inches center to center. The guard shall be securely attached to the outfall end section. The Contractor may submit other methods of constructing the trash guard subject to the approval of the Engineer.

**SS-2.9 Rip-Rap**

Where shown on the plans, rip-rap shall be constructed in accordance with MnDOT Specifications 2511 and 3601.

**SS-2.10 Base Material and Surfacing**

After backfill material has been shaped and compacted, the Contractor shall furnish and place the surface as shown on the typical sections.

## **SS-3 CONSTRUCTION REQUIREMENTS**

### **SS-3.1 General**

All streets shall be graded to the typical sections and profile grade as shown on the plans in accordance with the City of Fridley Standard Specifications for Street Construction.

### **SS-3.2 *New Subdivisions and Redeveloped Properties***

Before work begins on these parts, the developer is scheduled to grade the street to grade with no spot elevation to vary over 0.2 feet, and overall grading to within 0.2 feet. After the utilities are installed, the existing backfill material shall be compacted and reshaped to the required section as shown on the detail plan, and noted in the Standard Specifications. All excavation and shaping of these streets shall be incidental to the other items of the contract.

## **SS-4 SEWER SERVICE INSTALLATION (2621.3C)**

A 4-inch or 6-inch wye shall be used in the main line. An approved adaptor or other approved method of connection to the wye shall be installed.

When ductile iron service pipe is used, the sanitary wye shall be a standard ductile iron soil pipe fitting with slip joint and plug installed, watertight. When PVC service pipe is used, the PVC pipe shall conform to ASTM D-2321 and to the following specifications and standard detail plates:

Excavation shall be extended below the bottom of sewer grade as necessary to accommodate required granular bedding material as per the standard detail plate for PVC sanitary sewer service. Granular bedding and encasement for PVC (Schedule 40) services shall meet the requirements of ASTM 2321 and CEAM Standard Specifications for sanitary sewer and service line installation. Granular material for bedding and encasement of PVC (Schedule 40) sewer services is to be installed in unit bid price of PVC Services.

House connections shall be kept as deep as required to serve the property, with a minimum depth of 10 feet in the street and not less than 9 feet at the curb line. All exceptions are to be approved by the Engineer. All house connections shall be extended to or outside the right-of-way boundary at a minimum until the connection can be extended to the building.

All house connections shall be sealed by capping with stoppers firmly in place, or by other methods approved by the Engineer, which shall effectively prevent water from entering the sewer until the connection is placed in service.

## **SS-5 MANHOLE AND CATCH BASIN STRUCTURES (2621.3D)**

On streets that are not at design grade, sewer manholes shall be built with such additional adjusting rings or short manhole sections as necessary to allow for adjustment of the street to the proposed grade as shown on the plans. On other streets, manholes shall be set as shown on the standard detail sheets. Manhole casting tops shall be set to be ¼ to ¾-inch below the final street surface, when the street is paved.

In unpaved areas, manhole casting shall normally be placed 2 inches below the gravel surface or flush with the ground in lawn areas.

The Contractor, with the approval of the Engineer, where standard manhole sections cannot be used, as in junction and transitional manholes, may construct such sections of concrete materials set on a precast concrete base. The outside of block manhole sections shall be plastered with Portland cement grout as directed. Hollow concrete block will not be allowed for any manhole construction.

Catch basin manholes with precast inverts will not be allowed. The Contractor must pour and form the invert using concrete to match the installed pipe without backfill. Concrete used shall have a 28-day compressive strength of at least 4,000 psi. Concrete shall be delivered from a MnDOT certified plant with delivery tickets.

## **SS-6 SANITARY SEWER LEAKAGE TESTING (2621.3E)**

After completion of all utility construction by this contract and before any house services are connected, tests will be required of all sanitary sewer lines.

### **SS-6.1 Air Test Method (2621.3E1)**

The Contractor shall perform these tests with suitable equipment specifically designed for air testing sewers.

The sewer section under test will be accepted as having passed the air leakage test if it does not lose air at a rate to cause the pressure to drop from 4.0 to 3.5 psi in less time than one-half minute per inch in diameter of the pipe tested.

### **SS-6.2 Inspecting, Televising and Flushing (2621F) Deflection, (2621F1) Test Failure Remedy, & (2621G) Televising**

Prior to final acceptance of each section of the sewer line, the Contractor shall flush a ball, the full diameter of the sewer, through all sewers up to 24 inches in diameter. Larger sewers shall be cleaned by other appropriate methods. All dirt and debris shall be prevented from entering the existing sewer system by means of watertight plugs or other suitable methods.

Upon completion of the contract, the Engineer may require televising if visual inspection, leakage testing or deflection testing indicate that the work is unsatisfactory. All televising will be done at the Contractor's expense. Any unsatisfactory work shall be removed and replaced in a proper manner. The invert of the sewer and manholes shall be left smooth, clean and free from any obstructions throughout the entire line.

## **SS-7 RESTORATION OF SURFACE IMPROVEMENT**

The Contractor shall confine his work within the construction limits specified. In all instances, restoration of any disturbed areas outside the construction limits shall be at the expense of the Contractor.

That affected portion of the existing roadway and curb and gutter that is disturbed by this contract shall be replaced in accordance with the City of Fridley Standard Specifications for Street Construction. The materials shall be placed on thoroughly compacted subgrade. The trench shall be compacted in lifts not to exceed 1 foot in clay and silty soils. Compacted lifts of 2 feet will be allowed in sand and gravel soils.

## **SS-8 INTERRUPTION OF PRIVATE WATER SUPPLIES**

If any private water supply shall become interrupted, either temporarily or permanently, solely as a result of the Contractor's approved dewatering procedure, the Contractor shall be held harmless from any claims.

## **SS-9 METHODS OF MEASUREMENTS AND PAYMENT (2621.4 and 2621.5)**

### **SS-9.1 Sewer Pipe in Place (2621.4A)**

Sewer pipe shall be measured and paid for at the contract unit price per lineal foot for each type, for each diameter of pipe furnished and installed and according to the depth zone classification. Increases and reducers will be paid for at the contract unit price per lineal foot for the larger size pipe.

Unit prices bid shall be compensation in full for all costs incidental to construction, including but not limited to, excavation, pumping, testing, sheeting, pipe completely installed, backfilling, and necessary bends, wyes, and tee sections, unless otherwise included as a pay item.

**SECTION 6-ST**

**STREET CONSTRUCTION**



**SECTION 6 - ST STANDARD SPECIFICATIONS FOR STREET CONSTRUCTION –  
TABLE OF CONTENTS**

SECTION ST - STANDARD SPECIFICATIONS FOR STREET CONSTRUCTION ..... 2

ST-1 GENERAL CONDITIONS..... 2

ST-2 SCOPE OF WORK ..... 2

ST-3 SCHEDULING AND CONSTRUCTION PROGRESS ..... 2

ST-4 GAS SERVICE ..... 2

ST-5 EXISTING UNDERGROUND UTILITIES..... 2

ST-6 CONSTRUCTION STAKES - ALIGNMENT AND GRADES ..... 3

ST-7 REMOVAL OF MISCELLANEOUS STRUCTURES AND EXCESS MATERIALS ..... 4

ST-8 TRAFFIC PROVISIONS AND MAINTENANCE ..... 5

ST-9 CLEARING AND GRUBBING ..... 5

ST-10 EXCAVATION..... 6

ST-11 EMBANKMENT..... 7

ST-12 ADJUSTMENT OF EXISTING STRUCTURES ..... 8

ST-13 SUBGRADE PREPARATION AND TEST ROLLING..... 9

ST-14 CURB AND GUTTER, SIDEWALK AND SIDEWALK RAMPS ..... 10

ST-15 AGGREGATE BASE (2211)..... 12

ST-16 PLANT-MIXED BITUMINOUS SURFACE LOCAL AGENCY (2360)..... 13

ST-17 CONSTRUCTION REQUIREMENTS..... 14

ST-18 LANDSCAPING..... 17

ST-19 WATER..... 18

ST-20 EROSION CONTROL SUPERVISOR (2573)..... 19

## **SECTION ST - STANDARD SPECIFICATIONS FOR STREET CONSTRUCTION**

### **ST-1 GENERAL CONDITIONS**

The Standard Specifications for Highway Construction of The 2014 Edition of the “Minnesota Department of Transportation”, “Standard Specifications for Construction”, and the 2014 Edition of the “Materials Lab Supplemental Specifications for Construction”. Shall apply to all work and material to be furnished under this project except as modified below and by the Special Provisions for this project.

### **ST-2 SCOPE OF WORK**

The work to be done under this contract shall include the furnishing of all materials, labor, tools and equipment to construct complete in-place sidewalk, curb and gutter, bituminous surfacing and all appurtenant construction as shown on the drawings and specified. Under this contract, the Contractor shall excavate and compact suitable materials as shown in the plan, construct concrete curb and gutter, construct base and bituminous surfacing, protect, repair, relocate, maintain and restore all sub-surface, surface and overhead structures directly or indirectly disturbed, or affected by his operations and furnish all other appurtenant items and services necessary or specified.

### **ST-3 SCHEDULING AND CONSTRUCTION PROGRESS**

Prior to the start of any work, the Contractor shall submit in writing to the Engineer for approval, a progress schedule which shall be followed as closely as possible. Progress scheduling using critical path method is approved and encouraged. Once work has started on a street, it must be diligently pursued until the street is finished. Each successive phase of work will follow the preceding phase as closely as possible so that the time any one street is under construction is kept to a minimum. Should the Contractor, in the Engineer’s opinion, fail to complete the work as specified above, the Engineer may limit the work which has been started but not completed to any such amount as he deems reasonable. No extension of time will be granted to the Contractor for not being permitted to open new streets to construction for this reason.

### **ST-4 GAS SERVICE**

In the event it is necessary to cut any gas line to perform the necessary street grading, such cutting shall be performed by the gas company at no expense to the Owner. The cost of repairing any accidental breakage or damage to gas lines caused by the Contractors operation shall be the responsibility of the Contractor. All repair work, no matter how slight, shall be performed by the gas company.

The Contractor shall contact Gopher State One-Call 72 hours prior to any excavating and also upon causing any damage to the integrity of the coating on any gas line.

### **ST-5 EXISTING UNDERGROUND UTILITIES**

Every effort has been made to position and dimension all existing underground utilities on the plans. This information was obtained from the respective utility companies. The Engineer does not guarantee the locations as shown on the plans. It is the Contractor’s responsibility to ascertain the final location of these utilities (including municipal water and sewer lines and appurtenances) and to notify the utility companies when construction commences in each area.

The Contractor is responsible for the protection of all underground utilities which are located in the field or are shown on the plans. The Contractor shall adjust all manhole and catch basin castings, water valve boxes, and curb stop boxes which require such adjustment. After adjustment, all manholes, valve boxes, and curb boxes shall be ¼ to 3/4-inch below finished grade and in proper working order. Curb boxes and valve boxes must be plumb and concentric about the operating nut. Storm and sanitary sewers and water valve boxes must be carefully protected. Any sand or debris caused by the Contractor's operation must be immediately removed from the manholes, pipes and valve boxes. Before the Contractor removes manhole castings or lowers gate valve boxes, it shall be his responsibility to make location ties for these structures so they can be relocated accurately after the base course is constructed, in case of emergency use of these facilities.

The Contractor shall report to the Engineer in writing any undesirable conditions, such as sand in manholes, damaged valve boxes, broken castings, etc., prior to commencing work on any street. Once excavation or utility construction has commenced, it will be assumed that all damage to underground installations except that reported above, has been caused by the Contractor's operations and it will be his responsibility to make the necessary repairs.

It is the Contractor's responsibility to ascertain the location of these sprinklers. The Contractor is responsible for the protection of all sprinkler systems. Prior to removing any system, the Contractor shall contact the owner. If the system is removed for the Contractor's convenience, the Contractor shall repair and replace it at his cost.

Any sprinkler heads and/or piping disturbed during construction shall be repaired and relocated by the contractor. The sprinkler systems shall be repaired to as good or better condition with equal or better components as determined by the Engineer. The repair by the Contractor shall be their qualified representative with significant sprinkler repair experience. The Contractor shall remove, cap, reconnect, re-install, locate parts, and other work necessary to make all sprinkler zones operable the day of disturbance or damage. If the sprinkler system is inoperable beyond the next calendar day, the City or property may hire a sprinkler contractor to restore operation of the system. Permanent restoration to all components of the sprinkler system shall be completed within 7 calendar days of initial system disturbance. If the system is not restored within 7 calendar days, the City or owner may complete restoration. The Contractor shall reimburse the City or property owner for all costs for temporary repair and final restoration plus 10% administration costs. This item is considered incidental to the project with no additional compensation.

#### **ST-6 CONSTRUCTION STAKES - ALIGNMENT AND GRADES**

All work under this contract shall be constructed in accordance with lines and grades shown on the drawings and as established by the Engineer. These lines and grades may be modified by the Engineer as provided in the General Specifications.

The Contractor shall render such assistance to the Engineer as may be required to accomplish the staking for proper execution of the work.

The Contractor shall give the Engineer sufficient notice (2 working days) as provided in the General Specifications of his need for the establishment of line and grade. After lines and grades for any part of the work have been set by the Engineer, the Contractor shall be held responsible for the proper execution of the work to such lines and grades. All stakes or other marks given shall be protected and preserved by the Contractor until their removal is authorized by the Inspector. The Contractor shall, at his own expense, correct any mistakes caused by their unauthorized disturbance or removal. The Engineer may require that work be suspended at any time when, for any reason, such marks cannot be properly followed.

No additional compensation shall be allowed the Contractor for any claims of crews being held up because of lack of line and grade stakes, unless he has submitted a written request to the Engineer at least two working days in advance and is following a previously approved schedule of work.

#### **ST-7 REMOVAL OF MISCELLANEOUS STRUCTURES AND EXCESS MATERIALS**

This work shall consist of removing structures, such as pipe culverts, pavements, curbs, gutters, sidewalks, guard rails, fences, mailboxes, sewer and tile lines, manholes, catch basins, and other miscellaneous structures.

Mail boxes and stop signs which must be disturbed by construction, shall be relocated in a temporary position as directed by the Engineer and installed in their final location by the Contractor as directed by the Engineer as soon as appropriate. See Item C-10 of Section 2-C General Utility Construction Specifications for further clarification.

The Contractor shall remove and replace any fence within the construction limits of this contract. All fences shall be replaced in a condition at least equal to that which existed before construction.

All materials specified to be salvaged shall be carefully removed and hauled to the City of Fridley property at 400 71st Avenue NE. All traffic signs requiring removal will be removed by the Contractor unless noted otherwise. The Inspector will notify the Public Works Superintendent upon the regular two days notice from the Contractor.

Disposal areas for excess suitable material may be provided by the City of Fridley as specified in the Special Provisions. The Contractor shall dispose of all waste material and debris, and notify the Engineer of the disposal area. No waste material or debris shall be deposited on any public or private property within the City limits of Fridley without the written permission of the Engineer. Waste materials and debris shall include, but not be limited to, trees, stumps, pipe, concrete, asphaltic concrete, tin cans, or other waste material from the construction operations.

When excess suitable material is mixed with waste material, the Contractor shall segregate these materials and dispose of them separately when directed by the Engineer. Material shall be inspected prior to placement on construction site. The cost of removal and disposal of all miscellaneous structures and excess materials and all costs connected therewith shall be considered incidental to the Contractor for payment purposes unless specifically noted as a pay item in the Plans and Special Provisions, in which case there will be a pay item and a unit of measure listed in the Bid Proposal.

## **ST-8 TRAFFIC PROVISIONS AND MAINTENANCE**

Unless otherwise approved, the street under construction shall be kept open to all traffic by the Contractor at his own expense. Traffic shall be maintained to the fullest extent possible, especially during morning and afternoon rush hours. The street shall be graded and rolled smooth for weekend traffic. The work shall be scheduled to maintain access to the maximum extent possible.

Traffic Control shall be according to the latest edition of the Minnesota Manual on Uniform traffic Control Devices (MMUTCD) and Appendix B.

All detours required shall be approved by the Engineer prior to use. Detour signs and barricades shall conform to the illustrations in the plans and their placement shall be as directed by the Engineer. All detour signs shall be reflectorized. All barricades shall have blinker lights at each end. Properly equipped flagmen shall be used as required in order to facilitate good construction and provide safe driving conditions. Barricades and detour signs which are not in use shall be stored in the Contractor's construction yard.

Maintenance of the streets under construction, detours, bypasses, and equipment yards used in conjunction with the project shall be the responsibility of the Contractor. Said maintenance shall include keeping the streets free of obstacles, parked equipment, barricades which are not in use, blading and traveled ways and controlling the dust in the construction area.

When dust becomes or appears to become a nuisance or problem to the area or to the nearby residents, it shall be the responsibility of the Contractor to immediately alleviate the condition. The maintenance responsibility herein described shall be inherent to the Contractor and shall be applicable at all times, including weekends, throughout the construction period. The Contractor shall provide the name and telephone numbers of maintenance workers who can be contacted at all times. The Contractor shall provide periodic inspection of the project, particularly during and after storms, to maintain blinker lights and barricades, provide dust control and general maintenance. If the Contractor is negligent in this aspect, the City reserves the right to perform this work with its own forces at overtime rates. The cost of such work shall be charged to the Contractor.

Disregard of this provision shall be cause for suspension of the project until the Contractor can show evidence that workers have been hired specifically to perform the above work and will be on the project at all times.

Streets in the area, not under construction, shall be kept free of construction materials, dirt, or other undesirable material.

## **ST-9 CLEARING AND GRUBBING**

### ***ST-9.1 DEFINITION***

The work consists of removing and disposing of the trees, brush, stumps and other plant life, including dead and decaying matter, within the construction area, unless designated to remain by the contract or directed by the engineer.

### ***ST-9.2 CONSTRUCTION REQUIREMENTS***

Clearing shall be accomplished by removing the tree in a safe and considerate manner. Grubbing shall ordinarily be accomplished by excavation and removal. However, with the permission of the Engineer, grubbing may be partially accomplished with a grinding device. All roots and stumps shall be removed to a depth of not less than 12 inches below the original ground surface or the street excavation, whichever is lower. The Engineer shall designate those trees which require clearing, but not grubbing.

All trees and shrubs shall be protected from injury or defacement during construction operations, unless written permission is given for their removal by the Engineer. Current and pertinent government regulations concerning disposal of Elm trees shall be obeyed.

Cleared trees may be claimed by the abutting property owner. If so, they shall be trimmed and the trunks or logs cut in 8 foot lengths and neatly piled on private property. All other material shall be disposed of as Waste Material and Debris off-site.

### ***ST-9.3 METHOD OF MEASUREMENT AND PAYMENT***

The Engineer will only measure trees for payment having a diameter greater than 4in. at a point measured 24in. above the ground surface.

The Engineer will only measure stumps for payment having a greater diameter than 4in. when measured at one of the following points:

1. 2 ft above the ground for a tree cleared under the contract, or
2. The point of cutoff for an existing stump not cleared under contract.

If the contract does not include any separate items for clearing and grubbing, then all clearing and grubbing within the proposed construction limits shall be considered incidental to the other items of the contract.

## **ST-10 EXCAVATION**

### ***ST-10.1 DEFINITION***

Excavation shall consist of removing, to the designated subgrade as shown on the plans, existing material including soil, gravel, previously constructed surface, trees not paid as Clearing and Grubbing, shrubbery, and any other material not specifically noted as a pay item in the bid proposal.

### ***ST-10.2 CONSTRUCTION REQUIREMENTS***

All sod and vegetation shall be removed from the original ground within the construction limits. Suitable topsoil which is encountered during excavation shall be stockpiled and used as backfill material behind the curb where required. Stockpile locations are to be provided by the Contractor with the approval of the Engineer. No additional compensation will be made for stockpiling material. All stockpile locations shall be properly seeded and mulched at no additional compensation. Materials suitable for the construction of embankments, as determined by the Engineer, shall be placed in

embankments as provided in these specifications. Materials which the Engineer considers unsuitable shall be removed and replaced with material suitable for embankments.

Slopes shall be cut as shown in the plans and shall be neatly bladed and raked. Every effort will be made by the City to obtain the required easements prior to initial construction; however, it may be necessary for the Contractor to resume grading operations after easements are obtained. No additional compensation in addition to Common Excavation will be made for this inconvenience. Private driveways shall be graded as directed by the Engineer. Before forms are set for curb and gutter, all existing driveways shall be excavated or filled to the proposed subgrade elevation and opened for use as soon as possible. Driveways shall be surfaced with material as similar as possible to that existing prior to start of construction.

During construction, all excavations shall be maintained in such a condition that they will be well drained at all times. Temporary ditches or gutters shall be constructed when necessary to maintain drainage and avoid damage to the roadway. No excavated materials shall be placed or stockpiled in such a manner as to restrict free surface drainage of the subgrade or base courses. All embankments shall be completed before any excess suitable material is wasted.

### ***ST-10.3 METHOD OF MEASUREMENT AND PAYMENT***

Common Excavation will be paid for at the Contract unit price per cubic yard per plan quantity, and shall include all salvaging, stockpiling, placement, and maintenance of the reclaimed pavement and aggregate. This work will also include salvaging, grading and placement of topsoil behind the new curb and gutter as required. Excavation will be measured in its original position by the cross-section method, and the volume computed by the method of average and areas.

Subgrade Excavation will be paid for at the contract unit price per cubic yard, per plan quantity, and shall include removal, hauling and disposal of excavated materials off site. Excavation will be measured in its original position by the cross-section method and the volume computed by the method of average end areas.

## **ST-11 EMBANKMENT**

### ***ST-11.1 MATERIALS***

In general, embankment material shall be obtained from excavations on the project. Embankments placed on existing slopes shall be constructed in accordance with MnDOT Specifications 2105. Granular Borrow shall conform to the requirements of MnDOT Specification 3149. Other material for embankment shall be as specified in the Special Provisions.

The Contractor shall provide the Engineer with written notice of the source of embankment material and a 25 pound representative sample of the material not less than two working days in advance of the planned starting time for placement of the material.

### ***ST-11.2 CONSTRUCTION REQUIREMENTS***

Embankments shall be constructed in accordance with provisions of MnDOT Specification 2105. Embankments shall be thoroughly compacted by the ordinary compaction method unless specifically provided otherwise in the Special Provisions.

### ***ST-11.3 METHOD OF MEASUREMENT AND PAYMENT***

When payment is made for the excavation of the materials used in embankments, no additional compensation will be made for the embankment construction. When material for embankment is specified to be obtained from sources outside of the project right-of-way, there will be in the Bid Proposal a pay item entitled Granular Borrow and the unit of measurement will be Cubic Yard. Payment will then be made on the compacted volume (CV) of the material in its finished position. Volumes will be computed by the average end area method determined from original and final cross-sections. Payment for Granular Borrow shall be compensation in full for obtaining the material and constructing the embankment except for the water applied on the embankments.

## **ST-12 ADJUSTMENT OF EXISTING STRUCTURES**

### ***ST-12.1 MATERIALS***

Mortar shall consist of one part Portland Cement, three parts mortar sand and sufficient water for proper consistency. Sewer Brick and adjusting rings shall conform to the requirements of MnDOT Specification 3616 and 3621.

Precast adjusting rings shall conform to the size and shape of the frame base.

The backfill material, when adjusting manhole covers, shall be concrete having a 28-day compressive strength of at least 4,000 psi or other material approved by the Engineer.

Adjusting Rings manufactured from High Density Polyethylene (H.D.P.E.) are approved as an alternate to concrete adjusting rings. The H.D.P.E. adjusting ring shall be sealed with the product recommended by the manufacturer.

### ***ST-12.2 CONSTRUCTION REQUIREMENTS***

Existing manholes and catch basins shall be adjusted to meet the grades as established on the plans by either removing or adding sewer brick or adjusting rings. Sewer brick, adjusting rings and Castings shall be set firmly on a full bed of mortar. Contractor shall replace up to 12 in. of existing rings. Ring replacement in excess of 12 in. shall be determined by the Engineer. No wood blocking shall be used for any purpose in adjusting manhole or catch basin castings.

When the frame or ring casting cannot be adjusted as indicated above or the casting requires less than two 2 inch rings or more than 12 inch of adjusting rings, the Engineer shall be notified and shall determine the action to be taken by the Contractor. The backfill material shall be granular and thoroughly compacted in 12 inch layers.

After completion of the adjustment, any mortar, earth or other debris in the manhole or catch basin must be removed immediately and the sewer invert left in a clean condition.



The Contractor shall be fully liable for any damages incurred by the public as a result of sewer stoppages due to his operations. Upon notification of a sewer stoppage caused by his operation, the Contractor shall be required to remove obstructions and effect repairs when notified by the City. Should the Contractor fail to respond immediately to such notification, the City will take action as necessary to restore service. The Contractor shall be charged for work performed by the City on an overtime basis.

Valve boxes shall be adjusted by turning to the grades as shown on the plans, or by replacing the riser sections with a different length riser section.

All structures within the roadway shall be adjusted to final grade prior to constructing the bituminous wearing course. Final grade for a structure shall be 1/2-inch below the wearing surface and parallel to the widening surface. When a base course is excavated in order that a structure may be raised, the horizontal limits of said excavation shall be straight and shall extend such that the Contractor can compact the aggregate base with a mechanical tamper. The Contractor shall make location ties for all structures so that they can be easily located. Proper barricading and signing must be done during this operation to protect the public and to divert traffic from the freshly poured concrete. When relocating catch basins, the requirements of Standard Specifications for Storm Sewer shall govern.

### **ST-13 SUBGRADE PREPARATION AND TEST ROLLING**

#### ***ST-13.1 CONSTRUCTION REQUIREMENTS***

Subgrade preparation and test rolling shall be done prior to curb and gutter construction, placing of aggregate base, sand gravel sub-base, or plant mixed bituminous base on all streets unless otherwise noted on the plans. The street shall be graded, rolled, compacted, and shaped to the section as shown on the plans. The speed shall range between 2.5 and 5 mph.

The Contractor shall take any steps he deems necessary to protect underground pipe or utility installations during test rolling operations. Any underground installations damaged by test rolling shall be replaced at the Contractor's expense.

The road bed will be considered unstable if, under the operations of the roller, the surface shows yielding measured from the original surface to the bottom of the tire track.

After a roadway has been test rolled and determined satisfactory, subsequent failure due to inclement weather shall be repaired at no additional compensation. Likewise, the roadway shall be retest rolled after a rain event.

Any soft spots or displacements which appear during test rolling shall be corrected by scarifying, aerating or watering and re-compacting as required to obtain stability or by excavating to solid material and backfilling with in kind material suitable for base construction. Unsuitable material, such as vegetation, rubbish, large stones, peat, and wet clay, shall be removed and disposed of as directed by the Engineer. After correction, the area shall be test rolled as directed by the Engineer.

After compaction, the surface of the subgrade shall be smooth and true to crown and grade as shown on the plans. The elevation shall not vary more than 0.05 foot from that shown on the plans.

### **ST-13.2 METHOD OF MEASUREMENT AND PAYMENT**

There will be no measurement or payment in the Bid Proposal or specific compensation for subgrade preparation and/or test rolling unless so specified in the Special Provisions or bid proposal. Any additional subgrade excavation required will be measured and paid for at the contract unit price for such work, except at utility trenches constructed under this contract.

### **ST-14 CURB AND GUTTER, SIDEWALK AND SIDEWALK RAMPS**

#### **ST-14.1 GENERAL**

In general, sidewalks shall be constructed on the property line or 1 foot from the property line to provide a grass boulevard. In some cases a sidewalk easement will be obtained to allow a wider boulevard and protect trees. The sidewalk may be curved and/or raised if necessary to save trees or other improvements as determined by the Engineer.

Sidewalk ramps, including prefabricated truncated dome area, as detailed in the plans, shall be constructed where indicated on the plan or as directed by the Engineer. Where new sidewalks abut an existing curb and gutter, the curb and gutter shall be removed to construct the sidewalk ramp. Each ramp on the existing curb and gutter shall be completed as soon as possible after curb removal.

#### **ST-14.2 MATERIALS AND CONSTRUCTION REQUIREMENTS**

All materials and construction requirements shall conform to MnDOT Specification 2461.2 Table 2461-6 3F52 C and G, and the following paragraphs:

##### **ST-14.2.1 Structures**

The curb and gutter shall be built to fit any drainage structures which may be encountered. Normally, final adjustment of structures shall be made at the time the forms are set. The transitions from the regular curb and gutter sections shall be constructed as directed by the Engineer. The exposed surface shall be finished smooth in the same manner as the regular curb and gutter sections.

##### **ST-14.2.2 Joints**

Contraction joints shall be placed in the sidewalk at 5-foot intervals and shall align with like joints in the adjoining or neighboring work. Contraction joints shall be not more than 1/8 inch in width and shall be cut to a depth of not less than 3/4 inch.

In 6 inch concrete walk for driveways, contraction joints shall be placed so that no slab is larger than 100 square feet in area.

Expansion joints shall be placed in sidewalk and curb/gutter at 100 foot intervals and at the beginning and end of all radii, and shall align with like joints in adjoining work.

##### **ST-14.2.3 Placing Concrete**

Concrete shall not be placed on any foundation whose temperature is 32°F or less. During cold weather, concrete may be placed with the air temperature in the shade is 35°F and rising; concrete shall not be placed when the air temperature is below 40°F and falling. In no case shall concrete be placed upon a frozen subgrade. If the concrete has been placed in accordance with the above provisions and

the temperature drops to 32°F or less, the concrete shall be covered with dry burlap and a sufficient depth of straw to prevent freezing.

The Contractor shall place all types of membrane cure material homogeneously to provide a uniform solid white opaque coverage on all exposed concrete surfaces (equal to a white sheet of typing paper). The membrane cure shall be placed within ½ hour of concrete placement unless otherwise directed by the Engineer. Failure to comply with these provisions will result in a price reduction for the concrete item involved in accordance with Mn/DOT 1503.

#### ***ST-14.2.4 Backfill***

As soon as the concrete has attained a sufficient strength, the area in front and back of the concrete shall be backfilled with suitable material. The backfill material behind the curb shall be topsoil except at drives or as otherwise directed. The material on the street side of the curb shall be granular material suitable for base construction. The backfill shall be graded and shaped to the section as shown on the plans. Driveways shall be re-graded to a suitable condition as soon as the concrete has gained sufficient strength.

In the event that new concrete curb or valley gutter is installed adjacent to an existing street, the Contractor shall remove a portion of the existing pavement such that the aggregate base can be mechanically compacted along the new concrete curb or valley gutter.

#### ***ST-14.2.5 Dimension and Strength Requirements***

Prior to final acceptance of the work the City may take cores at random and at any suspected weak spots from the concrete to determine thickness and strength. Where the 28 day compression strength of a core is less than 3,900 psi and more than 3,500 psi, the concrete may be left in place and paid for at 75% of the contract unit price. Where the 28 day compression strength of a core is less than 3,500 psi and more than 3,000 psi, the concrete may be left in place and paid for at 50% of the contract unit price. Payment for a minimum of 100 linear feet will be so reduced by the adjustment in unit price for each deficient core.

Where the 28 day compressive strength is less than 3,000 psi, the City will designate whether or not such defective concrete must be removed and replaced at the Contractor's expense. (If left in place, the Contractor shall receive no compensation for the portion deficient in strength.) Where the concrete strength is less than 3,000 psi, additional cores shall be taken at the Contractor's expense to determine the extent of such deficiency.

Where a core is deficient in average thickness by more than 3/8 inch and less than 1 inch, the concrete may be left in place at the Contractor's option, and paid for at 50% of the contract unit price. A minimum of 100 linear feet will be so affected by the adjustment in unit price for each deficient core.

Where a core is deficient in average thickness by more than 1 inch, the City will designate whether or not such defective concrete must be removed and replaced at the Contractor's expense. (If left in place, the Contractor shall receive no compensation for the portion deficient in thickness.) Where the

concrete is deficient in thickness by more than 1 inch, additional cores shall be taken at the Contractor's expense to determine the extent of such deficiency.

**ST-14.2.6 Method of Measurement and Payment**

Concrete curb and gutter will be paid for at the contract unit price per lineal foot measured along the face of the curb at the gutter line. Payment shall be compensation in full for all costs incidental to construction, including (but not limited to) excavation not included in roadway excavation quantities, granular backfill when required, final adjustment of catch basins castings, expansion fillers and application of curing compound and treating oil. No additional compensation will be allowed by curb which is curved or for driveway openings which are constructed. Curved curb and driveway openings will be paid for as concrete curb and gutter. Concrete swales (measured outside normal curb and gutter) shall be paid as 6 inch concrete walk.

Concrete walk of each thickness will be measured by area and paid for at the contract unit price per square foot which shall be compensation in full for all costs incidental to construction, including (but not limited to) excavation not included in roadway excavation quantities; granular base when required, expansion fillers and application of curing compound.

Pedestrian curb ramps will be measured by area and paid for at the contract unit price per square foot which shall be compensation in full for all costs incidental to construction including (but not limited to) excavation not included in roadway excavation quantities; granular base when required, expansion fillers and application of curing compound.

Pre-fabricated truncated dome areas for pedestrian ramps will be measured by area and paid for at the contract unit price per square foot which shall be compensation in full for all costs incidental to the furnishing and installing per details provided in the plan set.

**ST-15 AGGREGATE BASE (2211)**

**ST-15.1 MATERIALS**

Aggregate base shall conform to the requirements of MnDOT Specification 2211. The class of aggregate will be shown on the Proposal. The weight used for converting the tonnage into compacted base shall be 105 pounds per square yard per inch. The City would pay up to 2-inch beyond the planned depth and the Contractor will not receive any payment for material laid beyond that depth.

The Contractor shall furnish the Engineer with a written statement as to the source of the material and shall deliver a 25-pound representative sample of the material which he intends to furnish not less than two working days in advance of placement of said material. Change of source shall not be made without approval of the Engineer.

**ST-15.2 CONSTRUCTION REQUIREMENTS**

The subgrade shall be prepared in accordance with ST-13. The aggregate base shall be compacted by the Specified Density Method according to Specification MnDOT Specification 2211.3.

Aggregate base shall be constructed in lifts not to exceed 4 inches in compacted thickness. Each course shall be shaped and compacted separately. After the material is placed on the roadway, it shall be shaped approximately to the grade and cross-section shown in the plans. Contractor shall use a rubber tire road grader (blade) to finish the grade of the subgrade and the aggregate prior to checking tolerance. A rubber tire road grader (blade) shall also be used for maintenance of the streets until the asphalt pavement has been placed. No aggregate shall be placed on the roadway that cannot be compacted within 24 hours.

Compaction shall be started as soon as possible after spreading and shall be completed within 24 hours. Compaction shall be done with an approved vibratory compactor capable of imparting a compactive force of at least 15 tons and shall continue until there is no evidence of further compaction. Water shall be added to obtain maximum compaction.

Each pass of the roller shall overlap the preceding pass by at least one-half the width of the roller and shall terminate at least 3 feet in advance of or to the rear of the termination of the preceding pass. The entire surface shall be rolled until there is no further compaction and until all roller marks are eliminated. After compaction, the surface of the aggregate base shall be smooth and true to crown and grade as shown on the plans. Prior to placing bituminous pavement, the Contractor shall remove, replace or rework segregated material. The thickness shall not vary more than 0.05 foot from that shown on the plans.

#### **ST-15.3 METHOD OF MEASUREMENT AND PAYMENT**

Aggregate Base of each class specified shall be measured and paid for at the contract unit price, which shall be compensation in full for base preparation and test rolling, obtaining the material and constructing the base except for water applied. Payment will be made on the cubic yard basis for the volume of compacted base as determined by the depth and width as shown on the typical section, and the length as shown on the plans. Aggregate base may also be measured by weight in tons or by the square yard if indicated on the Proposal.

#### **ST-16 PLANT-MIXED BITUMINOUS SURFACE LOCAL AGENCY (2360)**

Recycled Asphaltic Pavement Materials (RAP) shall be allowed up to 20% maximum by weight. **Recycled shingles is not allowed.**

**Base** bituminous shall be **Type SP12.5 SPNWB330B per MNDOT 2360.**

**Wear** bituminous shall be **Type SP9.5 SPWEA340B per MNDOT 2360.**

The Contractor shall reduce the amplitude to its lowest setting on the rollers

Pavement smoothness requirements of 2399 will not apply on this Project. The requirements of 2399.3D3 Surface Requirements (straight edge specification) will apply.

**Density shall be per MNDOT Ordinary Compaction Method (2360.6c).** The Contractor shall provide a portable nuclear density device (or equal as approved by the engineer) and operator at the beginning of

each days paving operation to determine the required density and establish the rolling pattern. Contractor shall provide written documentation to the City representative on-site which includes portable field density results and a description of the rolling pattern at the beginning of each days paving. A copy of this handwritten report shall be provided to the Engineer within 1 hour of the start of paving operations. If the Contractor deviates in any way from the established rolling pattern, the City shall be notified and the Contractor shall immediately provide nuclear density testing and re-establishment of rolling pattern with documentation.

Contractor shall block off side streets while paving. Contractor shall be responsible for the cost of cleaning bituminous materials (tack, asphalt, etc.) off any vehicle that drives through the work area during paving.

The area of any new asphalt pavement patching required to correct deficiencies or damage (drainage, structure adjustment, fluid spills, skid loader scrapes, etc.) shall be measured and the corresponding tonnage shall be deducted from asphalt pavement item (i.e. SP9.5 Wear Course SPWEA340B).

When performing any handwork with the bituminous asphalt pavement, the Contractor shall use greater care in raking out larger rocks so as to minimize a segregated surface. The non-equipment operating foreman on-site shall inspect hand worked areas and place fines into surfaces found to be deficient. Poor workmanship may result in suspension of paving operations. Deleterious items found in the hot mix bituminous such as chunks, metal, rubber, rocks, and excess bit shall be immediately removed and placed on the curb line. All deleterious materials shall be collected at end of the day to allow for immediate review by the City and the Superintendent. After review, the Contractor shall immediately dispose. Excessive deleterious items found in the pavement material may result in suspension of paving as determined by the Engineer.

## **ST-17 CONSTRUCTION REQUIREMENTS**

### ***ST-17.1 Equipment***

Equipment which is used in the production, hauling, laying and rolling of the plant-mixed bituminous surface or base shall conform to MnDOT Specification 2360.

#### ***ST-17.1.1 Restrictions***

Bituminous surface shall be placed only during the hours of daylight (except as noted below) and when the road surface is dry. Base and binder course mixtures may be placed when the air temperature is 33°F or more and rising, but shall not be placed when the air temperature is 40°F or less and falling. Modified mixture, when used as a thin overlay, shall be placed when the air temperature is 60°F or more and rising. Wear course mixture may be placed when the air temperature is 50°F or more and rising. Mixtures shall not be placed when, in the opinion of the Engineer, the weather or roadway conditions are unfavorable. Mixtures shall not be placed on any surface that is below 33°F.

If traffic or other conditions warrant, mixtures may be placed at night under conditions specified by the Engineer.

### ***ST-17.1.2 Preparation of the Base***

The final shaping and compacting of the base shall be done just prior to constructing the plant-mixed bituminous pavement.

The finished surface of the base shall show no variation greater than 1/4 inch from a 10-foot straight edge laid parallel to the centerline or perpendicular to the centerline of the roadway.

All variations shall be repaired before paving operations start. All repairs shall be made by scarifying, shaping, adding material, if necessary, and rolling until the desired compaction and shape is obtained. All repairs shall be at the direction and with the approval of the Engineer, at no additional compensation.

Prior to bituminous material being placed, the road surface shall be swept free with of all dust and other objectionable material. The sweeping shall be performed with a pickup sweeper or in a manner which precludes dust and debris being deposited on the boulevard or lawn. Tack coat shall be applied in accordance with MnDOT Specification 2357.

### ***ST-17.1.3 Placement of Plant Mixed Bituminous Pavement***

The mixture shall be hauled to the site of paving and placed as soon as possible after mixing.

The mixture shall be spread without segregation, at the specified rate and to the cross section shown in the plans. The Contractor shall be responsible for obtaining the proper yield. Deductions may be made for overrun of the bituminous mixture. The estimated quantities are computed on the basis of 110 pounds per square yard per inch.

The placement of each course shall be completed over the full width of the street under construction on each day's run.

### ***ST-17.1.4 Rolling and Compaction***

After the mixed material has been placed as specified above, the initial rolling shall be accomplished by means of a tandem steel wheeled roller. The rolling shall follow as closely behind the spreading operation as practicable without causing undue displacement of the mixture. The rolling shall begin longitudinally at the outer edges of the course and progress toward the centerline. Each pass of the roller shall overlap the preceding pass by at least one-half the width of the roller and shall terminate at least 3 feet in advance of or to the rear of the termination of the preceding pass.

Following the initial rolling the entire surface shall be rolled by pneumatic-tired rollers until there is no further evidence of consolidation. The finish rolling of the wearing course shall be done with a tandem steel-wheeled roller until all roller marks are eliminated. After compaction, the surface shall be smooth and true to crown and grade as shown on the plans.

After compaction, the thickness of each course shall be within 1/4 inch of the thickness shown on the plans for that course. The material used in the excess mixture will be excluded from pay quantities.

After compaction, the finished surface of each course shall be smooth and true to the planned grade. The surface of the binder and wearing course shall not vary greater than 1/4 inch from the edge of a 10-foot straight edge laid thereon parallel to, or at right angles, to the center line.

These restrictions shall be strictly enforced. It shall be the discretion of the Engineer to require any unacceptable surface, or any surface not meeting the above restrictions, to be moved and replaced.

***ST-17.1.5 Paving Height at Manhole Castings***

The Contractor shall use a 3/8" plywood paving cover (cookie) for all manhole castings when installing the wear course pavement. All plywood covers will be removed after the pavement has been rolled and cooled. Any structure casting not meeting the paving height requirement after wear course is completed will be corrected at the contractor's expense, and the repair patch will extend no less than 10 feet longitudinally on each side of the structure, and curb to curb, unless otherwise approved by the Engineer.

***ST-17.1.6 Miscellaneous Bituminous Details***

Transverse joints in adjacent strips shall be separated a minimum of 1 foot. When the material is placed in more than one layer, longitudinal joints in adjacent layers shall be separated a minimum of 1 foot. Traffic shall not be permitted over an unmatched longitudinal joint except at locations directed by the Engineer.

When making a connection to an existing bituminous stabilized surface, the plant-mixed bituminous surface shall be tapered to provide a smooth connection as directed by the Engineer. When connecting to an existing asphaltic concrete mat, the joint shall be made vertical and painted with a uniform tack coat of bituminous material.

Unless otherwise directed by the Engineer, the construction of each pavement course shall start at the point farthest away from the mixing plant and progress toward the plant, so that no hauling will be done over freshly laid pavement.

No traffic other than that necessary for compaction purposes shall be allowed on any course of the pavement until the course has completely cooled and set.

Bituminous material shall not normally be deposited on the road if the rolling cannot be completed before dark.

Bituminous material shall be weighed on an approved scale at the plant and the weights recorded on a weight ticket approved by the Engineer. The Contractor shall be responsible for taking weight tickets from drivers. A copy of the scale weight tickets for the days run shall be furnished to the Engineer at the end of each working day and shall indicate the street or streets on which the material was placed. A running total for each day's run shall be recorded on the weight tickets. Periodic checks of the Contractor's scale may be made by weighing batch trucks on an independent scale to be specified by the Engineer. A cost of using the independent test scale is to be paid by the City. Weight of the trucks shall be controlled so that no damage will be inflicted upon the base or any haul road.



**ST-17.2 METHOD OF MEASUREMENT AND PAYMENT**

**ST-17.2.1 Plant-Mixed Bituminous Pavement**

The plant-mixed bituminous pavement shall be measured and paid for at the contract unit price per ton in place, which shall be compensation in full for all costs incidental to construction including bituminous materials used in the mixture.

In all cases the unit of measurement shall be tons and the weight determined on a scale approved by the Minnesota State Bureau of Weights and Measures.

**ST-17.2.2 Bituminous Tack Coat**

Bituminous material for tack coat shall be measured and paid for at the contract unit price per gallon which shall be compensation in full for all costs incidental to construction. Bituminous materials will be measured by volume at 60°F.

**ST-18 LANDSCAPING**

**ST-18.1 MATERIALS**

Sod shall be cultured, but otherwise conform to MnDOT Specification 3878. Seed mixture shall meet the following specifications:

Name of Seed  
Percentage Seed by Weight  
Minimum Germination

Park Kentucky Bluegrass  
20%  
80%

Kentucky Bluegrass  
30%  
75%

Creeping Red Fescue  
30%  
85%

Perennial Ryegrass  
20%  
90%

The seed mixture shall not contain in excess of 0.5% weed or 0.5% crop seed. Inert matter shall not be present in excess of 6.0% of the mixture by weight. Graded seed mixtures under brand names may be acceptable if they approach the above specifications and if approved by the Engineer.

Topsoil shall meet the requirements of MnDOT Specification 3877. In addition, topsoil shall be pulverized and free from heavy clay, coarse sand, stones, plants, roots, sticks, and other foreign materials.

#### ***ST-18.2 CONSTRUCTION REQUIREMENTS***

Landscaping shall be done in locations designated on the plans or at other locations as directed by the Engineer. The work shall include the replacing of all sod which has been disturbed or uprooted by other phases of the contract.

Prior to placing any topsoil the slopes shall be cut uniformly such that the finished sodded slope shall conform to the designated section. The topsoil shall be raked and all lumps and irregularities removed prior to placing the sod or seed. Care shall be taken to ensure that the topsoil does not contaminate the subgrade or base of the street driving surface. Topsoil remaining on the finished street shall be cleaned up immediately following the seeding or sodding operation. All sod and seed shall be placed on a minimum of 4 inches of topsoil regardless of the previous condition of the lawn. Unsuitable sod, which dies within 30 growing days after placement, shall be replaced at no additional compensation. Maintenance of sod and seed (including watering) shall be in accordance with MnDOT Specification 2575.3.

If requested by the Engineer, the Contractor shall furnish a test report from an approved reputable testing company, of the material to be used as topsoil - the cost of such tests to be paid by the Contractor.

All sod shall be rolled within 24 hours after its placement with a roller that leaves the sod smooth and the joints properly closed. The new sod shall be level with existing adjacent sod and shall also be level with the top of adjacent curb and/or sidewalk. Where required, sod shall be pegged such that it remains in position originally placed.

#### ***ST-18.3 METHOD OF MEASUREMENT AND PAYMENT***

Sodding will be paid for at the contract unit price per square yard as measured in place. This item shall include full compensation for sod, watering, topsoil and labor involved in restoring the construction site. Sod shall be measured and paid on the basis of square yards measured in the field by the Engineer. The Contractor shall provide invoices for the gross quantity of sod placed on the project. Sod shall be watered and guaranteed for 30 days after installation.

#### ***ST-19 WATER***

The Contractor shall make arrangements with the Fridley Water Department of the City of Fridley before using any municipal water. The Contractor will not be charged for water that is used for this project. The Contractor is not allowed to use City water for any other projects. All municipal water used must be metered by a meter obtained through the City.

All valves shall not be operated by the Contractor but shall be operated in accordance with the requirements of the City. The City shall be given 2 days' notice prior to operating valves.

The Engineer may exercise his authority regarding the amount of water used for any purpose and the Contractor shall, when directed by the Engineer, use more or less water as directed.

**ST-20 EROSION CONTROL SUPERVISOR (2573)**

Section 2573.5H is deleted and replaced with the following:

Providing the Erosion Control Supervisor for this Contract shall be considered incidental work for which no direct payment will be made.

**ST-21 ESTABLISHING TURF AND CONTROLLING EROSION (2575)**

MnDOT 2575 is modified as follows:

Item 2575.512 "Mulch Material, Type 3" is changed to Item 2575.513 "Mulch Material, Type 5".

Item 2575.570 is changed to "Rapid Stabilization Method 2" by the acre [hectare]

**SECTION 7-W**

**WATERMAIN CONSTRUCTION**

**Section 7 - W Watermain and Service Line Construction - Table of Contents**

W-1 GENERAL CONDITIONS (2611 .1)..... 2  
W-2 MATERIALS (2611.2)..... 2  
W-3 CONSTRUCTION REQUIREMENTS (2611.3) ..... 4  
W-5 WATER SERVICE INSTALLATION (2611.3C)..... 6  
W-6 CONNECTION TO OR INTERRUPTION OF EXISTING FACILITIES ..... 6  
W-7 DISINFECTION (2611.3E)..... 8  
W-8 RESTORATION OF SURFACE IMPROVEMENT ..... 9  
W-9 OPERATIONAL INSPECTION ..... 9  
W-10 TESTING OF WATERMAINS AND SERVICES..... 9  
W-11 METHODS OF MEASUREMENT AND PAYMENT (2611.4) ..... 10  
W-12 EROSION CONTROL ..... 11  
W-13 TEMPORARY WATER SYSTEM..... 11

## **SECTION W - WATERMAINS AND SERVICE LINE CONSTRUCTION SPECIFICATIONS**

### **W-1 GENERAL CONDITIONS (2611 .1)**

The "Standard Utility Specifications for Watermain Service Line Installation as prepared by the City Engineers Association of Minnesota 2013" shall apply to all work and material to be furnished under this project except as modified below and by the Special Provisions for this project.

Copies of Standard Utilities Specifications are available at the League of Minnesota Municipalities, 300 Hanover Blvd., St. Paul, Minnesota 55101.

### **W-2 MATERIALS (2611.2)**

All materials shall be new and not previously used unless specific exemption is granted by the City Engineer.

All materials shall be made in the USA.

#### ***W-2.1 DUCTILE IRON PIPE OR DUCTILE IRON FITTINGS (2611.2A1)***

All pipe joints shall be approved slip type mechanical joint with rubber gasket except for hydrant assemblies. Gaskets shall be molded rubber rings made expressly for the joint used. Compression fittings not permitted.

Electrical conductivity must be provided across each joint by means of metal straps fastened across the pipe joint or an approved conductive gasket with copper inserts similar to "Fastite" by American Cast Iron Pipe Company. The connection must be capable of withstanding 600 amperes of current and must be approved by the Engineer.

When so directed by the Engineer, the Contractor shall provide accurate scales near the site of the construction. He shall weigh a sufficient number of pipes and fittings from each shipment to verify the weight. Should the weights prove inconsistent, the Engineer may require the weighing of all materials delivered. The cost of all weighing shall be at the Contractor's expense.

#### ***W-2.2 CONCRETE PRESSURE PIPE AND FITTINGS (2611.2A2)***

Concrete pressure pipe and fittings shall not be incorporated in the system.

#### ***W-2.3 FIRE HYDRANT ASSEMBLY (2611.2B)***

Hydrant length shall provide for a cover of 7 feet 6 inches over the centerline of the lead pipe. In the event existing grade necessitates the use of a longer hydrant, the contractor shall furnish and install this with no extra compensation.

Where hydrants are set in areas in which the ground water is within 2 feet of the bottom of the hydrant, the drain plugs in the hydrant shall be plugged. A metal plate shall be placed on the hydrant in a conspicuous place and stamped with the following:

NOTICE: HYDRANT MUST BE PUMPED OUT AFTER USE TO PREVENT FREEZING

Where the water table is more than 2 feet below the elevation of the bottom of the hydrant, a pit 2 feet 6 inches deep shall be excavated below the elevation of the drain hole of each hydrant and filled to a level of 6 inches above the drain hole with 1½ inch clean gravel or river rock. Under no circumstances shall a drain be connected to any sewer.

Hydrants shall be flanged Waterous Pacer Model No. WB-67 with Minneapolis thread and one 4 ½ inch pumper nozzle and two 2 ½ inch side nozzles. All hydrants to have year of manufacturer and shall not be more than one year older than year of installation.

#### ***W-2.4 GATE VALVES AND BOXES (2611.2C1 AND 2611.2C2)***

All gate valves up to and including 12 inches in diameter shall be iron body. All gate valves shall be Waterous. Valves at meter to be gate or other full-way valve.

Gate valves, fittings, plugs and caps shall be set and jointed to new pipe in the manner specified for laying and jointing of pipe. Valves in watermain shall, where possible, be located on the street lines extended unless shown otherwise on the plans.

Unless otherwise shown on the plans, valves 16 inches and larger shall be provided with precast concrete vaults or manholes placed over the operators.

Watermain vaults may consist of precast concrete manhole sections and shall be manufactured to standards at least equal to or greater than the requirements of the Standard Specifications for reinforced concrete culvert storm drain and sewer pipe, ASTM designation C76-72 for Class II. The internal diameter shall be as shown on the detail drawings. Precast top and lower sections for manholes shall conform to requirements as shown on the detail drawings.

Cast iron for manhole frames and covers shall be not less than Class 30 or grey iron free from all injurious defects and flaws and shall conform with ASTM designation A48-64. All covers must fit closely in the rings in any and all positions to that there will be no rocking from pressure applied on any point of the cover. All castings shall conform to the weight, type and size as shown on the detail drawings. Covers shall bear the words "Water" on the top. The supplier of castings must be approved by the Engineer. The supplier shall certify to the Engineer that each shipment conforms to these specifications. Such certification shall accompany each shipment to the job site.

Butterfly valves, including all accessories, manholes or vaults, and frames and covers shall be considered as an integral unit, and the bid price shall include all of these items.

#### ***W-2.5 AIR RELEASE VALVE ASSEMBLY***

Air release valve assembly shall consist of a vented vault positioned over the watermain where the air vacuum valve is installed.

The vault for the air release valve shall consist of precast concrete manhole sections which shall conform to the requirements for watermain vaults specified above and shall conform to the requirements as shown on the detail drawings.

## **W-2.6 BLOWOFF VALVE ASSEMBLY**

### **W-2.6.1 Temporary Two-Inch Blowoff Assembly**

Temporary 2-inch blowoffs shall be installed in those portions of the watermains which could not be chlorinated, flushed, or tested by other means.

The 2-inch blowoff assembly consists of all valves, pipe and materials necessary to install the blowoff valve complete in place and shall be constructed in accordance with the detail drawings.

### **W-2.6.2 Six-Inch Blowoff Assembly**

A 6-inch blowoff valve shall be installed at each low point in all watermains of 16-inch-diameter or larger. The blowoff valve assembly shall consist of a line tee, 6-inch-diameter blowoff line, a valve, vault and accessories.

The vault shall conform to the requirement for watermain vaults detailed above and shall conform to the requirements as shown on the detail drawings.

## **W-2.7 WATER SERVICE PIPE AND FITTINGS (2611.2D)**

### **W-2.7.1 Curb Stop and Box**

Curb stops shall be manufactured by Mueller or Ford without drain, suitable for flared copper inlet and outlets.

Curb boxes shall have stationary shutoff rod and 1-inch steel pipe upper section adjustable up or down 6-inches from 7-feet of cover. Curb box base casting shall be threaded to match the curb stop. Lids to have pentagon plug with the word "Water" in raised letters.

### **W-2.7.2 Corporation Stops (1 inch Minimum)**

Corporation stops shall be Mueller or Ford with flare-type joint or service pipe and threaded on inlet end with standard corporation stop thread.

## **W-3 CONSTRUCTION REQUIREMENTS (2611.3)**

### **W-3.1 GENERAL**

All streets shall be graded to the typical sections and profile grade as shown on the plans in accordance with the City of Fridley Standard Specifications for Street Construction. After backfill material has been shaped and compacted, the Contractor shall furnish and place the surface as shown on the typical sections.

### **W-3.2 NEW SUBDIVISIONS AND REDEVELOPMENTS**

Before work begins on these parts, the developer is scheduled to grade the street to grade with no spot elevation to vary over 0.5 foot, and overall grading to within 0.2 foot. After the utilities are installed, the



existing backfill material shall be compacted and reshaped to the required section as shown on the detail plan, and noted in the Standard Specifications. All excavation and shaping of these streets shall be incidental to the other items of the contract.

**W-4 PIPE LAYING OPERATIONS (2611.3A)**

Fine grading to trench bottom, should be true and even so that the barrel of the pipe will have soil support for its full length, shall proceed ahead of the pipe laying; and should any over-excavation exceed 2 inches be encountered, the material added shall be moistened and compacted to the satisfaction of the Engineer, or foundation material shall be added at the expense of the Contractor. A minimum of one pass each side of pipe with mechanical tamper (Wacker style) regardless of backfill material.

Before lowering and while suspended, the pipe and fittings shall be inspected to detect any cracks. Any defective, damaged, or unsound material shall be rejected. All foreign matter or dirt shall be removed from the inside of the pipe and fitting before it is lowered into its position in the trench, and it shall be kept clean by approved means during and after laying. When connecting to existing stubs, the Contractor shall take every precaution necessary to prevent dirt or debris from entering the existing lines. All necessary work to make the connection shall be done at no additional compensation, except where noted otherwise.

The pipe shall be supported for the bottom 180 degrees and throughout its length as shown on the plans. Bell holes shall be dug adequate to make the joint, but no larger than necessary, so that maximum support on undisturbed ground will be provided for the pipe. The remainder of the pipe shall be surrounded to a height of at least 12 inches above its top by granular materials or other suitable material as determined by the Engineer, shovel placed and hand tamped to fill completely all spaces under and adjacent to the pipe.

Metal restraints shall be installed as shown on the detail sheets. When used, they shall be treated to prevent rusting and wrapped with 8 mil polyethylene in accordance with 2611.2E. All restraints, bolts, nuts, cad-weld shall be coated with bitumastic coal tar with couplings (if used) designed for use with such restraints. Where restraints are required, they will tie back at least two full lengths of pipe. A length of pipe will be counted only if the collar rests against the bell of that pipe. Friction between the collar and pipe shall not be counted as that pipe. Friction between the collar and pipe shall not be counted as holding thrust forces. The collar shall rest against a bell of a pipe in all instances or shall be connected to a flange on a valve or fitting.

Testing of lines shall not proceed until concrete thrust blocks have had sufficient time to attain design strength. High early strength concrete may be used. Ready mix concrete shall be poured behind all bends except 11½ inch bends and be witnessed.

Fitting Size (inches)	Quantity of Concrete (cu. ft)
6	2.5
8	4
12	9
16	16

When connecting to existing stubs, the Contractor shall take every precaution necessary to prevent dirt or debris from entering the existing lines. All necessary work to make the connection shall be done at no additional compensation, except where noted otherwise.

**W-5 WATER SERVICE INSTALLATION (2611.3C)**

Water services shall be located at least 3 feet, measured horizontally and 1.5 feet measured vertically, away from the sanitary sewer services, 10 feet from all other sewer services, and in a convenient location for the benefitted property.

Copper service pipe shall be installed continuously without joints between the corporation stop at the watermain and the curb stop. Prior to connecting the new copper service pipe to the existing service pipe, the Contractor shall flush the existing service line from the house until the service is free of any material which may clog screens in the water meter or plumbing fixtures. The Contractor shall be responsible to coordinate the flushing of existing services with the property owners. The Contractor shall also be responsible to unclog and clean all meters and plumbing fixtures.

All service pipes shall be installed at least as deep as the main through its entire length with a minimum cover of 7½ feet.

**W-6 CONNECTION TO OR INTERRUPTION OF EXISTING FACILITIES**

Prior to connecting to existing watermains, the Project Inspector and the Water Supervisor must be notified. Any residents who will be affected by a planned water shut down shall be given 48 hour advance notice as to when and for how long service will be interrupted.

The Contractor shall at all times coordinate his work with the City Engineer. When it is necessary to connect to the existing water system or close existing portions of the water system due to construction operations, the Contractor shall discuss that phase of the project with the Water Supervisor five working days in advance of the planned starting date to allow for orderly planning and coordination by the Water Division.

The Contractor shall take the steps considered necessary by the Water Supervisor for the protection of the existing water system and the health and reasonable convenience of water users. No water shall be shut off or work done on the existing water system without approval of the City Engineer. Water shall not be shut off before 9:00 a.m. and shall be restored by 3:00 p.m. the same day, unless approved by the City Engineer.

The Contractor will give at least 48 hours prior notification to the Water Supervisor of any necessary valve operations or of any closings of the existing water system.

ALL WATERMAIN VALVES THAT ARE IN SERVICE SHALL BE OPERATED BY AUTHORIZED WATER DIVISION PERSONNEL ONLY. Unauthorized operation of the valves is subject to fines under City Code. The Contractor shall conduct his operation in such a manner as to minimize inconvenience to the public due to disconnected water service.

In the event water service is disconnected beyond the specified time, the City Engineer shall have the authority to order a temporary utility service installed by utility forces or by a third party at the Contractor's expense.

Prior to connecting to existing watermains, the Contractor shall prepare all labor, materials, and equipment ready to do the work, so as to keep the shut off time to a minimum. As soon as possible after making the connections, the Contractor shall flush the new main at a velocity not less than 3 feet per second so as to prevent any contamination of the existing facilities.

The Contractor shall take every precaution necessary to prevent dirt or debris from entering the main. Watermain connections shall be made under pressure where shown on the plans.

It will be necessary for the Contractor to tap copper water services into existing mains where shown on the plans or directed by the City Engineer. The water service materials shall be paid in the same manner as other services.

Hydrants and auxiliary valves shall be supported upon a precast concrete base 18 inches square and a minimum of 5 inches thick. Each hydrant is to be securely tied back to its auxiliary valve, and that valve tied back to the tee as shown on the detail sheet with use of approved restraint system.

All hydrants shall stand plumb and shall have their nozzles parallel with or right angles to the curb, with the pumper nozzle facing the curb, unless otherwise instructed by the City Engineer. Each hydrant is to be braced against the far end of the trench by concrete blocks or poured concrete placed against the base of the hydrant. Hydrants must maintain a vertical position and must not be knocked out of plumb during the backfilling. Hydrant leads shall be compacted per Section 4.0.

Hydrants shall be set so that the pumper nozzle shall be a minimum of 18 inches above the final sodded grade. Hydrant tees shall be set exactly at the specified minimum depth of cover and the lead to the hydrant shall be at a level grade. When the installation of the hydrant involves the disturbance of sodded land, all black dirt and sod that has been disturbed shall be replaced to the original or better condition.

Care shall be taken when handling hydrants to protect the paint. Whenever the paint is chipped or scratched, the Contractor shall repaint the hydrant.

A valve box or a masonry pit shall be provided for every valve. Cast iron valve boxes shall not transmit shock or stress to the valve, shall be firmly supported and be centered and plumb over the wrench nut

of the valve, with the box cover flush with the surface of the finished pavement or such other level as may be directed. All geared valve and any other valves as may be designated shall be set in masonry valve pits and shall be so positioned to be readily assessable for operation from within the pit. Pits shall be constructed in a manner that will permit minor valve repairs and to afford protection to the pipe from impact where it passes through the pit walls.

All fittings, when positioned at the end of, or at bends in a line, shall be solidly braced against the end or sides of trench. All fittings shall be blocked with concrete. The concrete shall have a minimum compressive strength of 3,000 psi and the block shall be of sufficient size so as not to exert more than 3,000 psi foot pressure against the soil. Concrete blocking for a plug shall be poured 1 foot to 2 feet away from the plug and a 6 inch by 6 inch timber members shall be driven in between the plug and the block. All timber shall be oak or other durable hardwood. The cross sectional area of the timber blocks shall be at least one-half the cross sectional area of the pipe

**W-7 DISINFECTION (2611.3E)**

**W-7.1 GENERAL**

The Contractor shall disinfect and test all mains at no additional compensation regardless of existing conditions. This may include repairing existing facilities that must be included in the test and are not capable of holding test pressures. Mains shall be disinfected at 50 mg/L of chlorine initially with a residual of at least 25 mg/L after 24 hours. All valves and hydrants in the lines being disinfected shall be opened and closed several times during this contact period. This procedure shall be repeated, if necessary, until satisfactory results are obtained. The chlorine shall be introduced into the new main by use of tablets attached with permatex No. 1 to the top of pipe interior at time of pipe laying. See following table for tablet guide.

**Chlorine Dosage for Watermain**

<b>Pipe Size Inches</b>	<b>Pipe Length Feet</b>	<b>No. of 1/4 oz Tablets of 70% HTH</b>
4	18	1
6	18	1
8	18	2
10	18	3
12	18	4
16	18	8
18	18	20
1 oz = 4 tablets to be attached to top of pipe with permatex No. 1		

\* Based on 70% concentration of active chlorine.

**W-7.2 BACTERIOLOGICAL TEST**

Water from all new mains must successfully pass a bacteriological test before the main is placed in service.

**W-7.3 SAMPLING**

The City will take all necessary samples for bacteriological test of the water and provide any equipment necessary to take these samples at no cost to the Contractor.

**W-7.4 RECHLORINATION**

When unsatisfactory results are obtained from bacteriological tests, the City Engineer may direct the Contractor to rechlorinate the main. When rechlorination is deemed necessary, it will be done by the Contractor at no additional compensation in accordance with the provisions of AWWA C601.

**W-7.5 FLUSHING MAIN**

The entire line shall be flushed after a contact period of 24 hours and such flushing continued until the residual chlorine content is not greater than 0.2 ppm. The entire line, including hydrants leads, branch lines, and dead end mains shall be flushed.

All flushing shall be performed in the presence of City of Fridley personnel. The Contractor shall be responsible for disposing of the water from flushing in a safe and satisfactory manner.

**W-8 RESTORATION OF SURFACE IMPROVEMENT**

The Contractor shall confine his work within the construction limits as specified. In all instances, restoration of any disturbed area outside the construction limits shall be at the expense of the Contractor.

That portion of the existing roadway and curb and gutter that is disturbed by this contract shall be replaced in accordance with the City of Fridley Standard Specifications for Street Construction and the Fridley City Code Chapter 407 (Right-of-Ways). The materials shall be placed on thoroughly compacted subgrade. The trench shall be compacted in lifts not to exceed 1 foot.

**W-9 OPERATIONAL INSPECTION**

At the completion of the project and in the presence of a City representative, the Contractor shall operate all valves, hydrants and water services to ascertain that the entire facility is in good working order, that all valve boxes are centered and valves are opened; that all hydrants operate and drain properly; that all curb boxes are plumb centered; and that water is available at all curb stops.

**W-10 TESTING OF WATERMANS AND SERVICES**

All testing and disinfection of the finished pipe line shall be done at the expense of the Contractor and shall be considered a part of the price bid for the construction of the pipe line. All tests shall take place after the operational inspection is satisfactory. All tests shall be performed in the presence of City of Fridley personnel.

The maximum length of pipe tested as one unit is 800 feet without exception.

**W-10.1 HYDROSTATIC TEST (2611.3G)**

After all the pipe has been laid and all the hydrants, valves and appurtenances connected and the trench has been backfilled, the entire new construction shall be subject to a hydrostatic pressure test. A domestic water service line shall be tested at 150 psig for a period of 2 hours. An acceptable test shall be a maximum pressure drop of 2 psig. Designated fire lines A designated fire line shall be tested at 200 psig for a period of 1 hour. An acceptable test shall be a maximum pressure drop of 1 psig.

After each valved section of pipe is slowly filled with water, the test pressure, as measured at the point of lowest elevation in any pipe, shall be applied by means of a pump connected to a pipe in a satisfactory manner. The pipe connection, pump gauges, meters and all apparatus necessary for the test shall be furnished by the Contractor. The

Contractor shall furnish the test pressure gauges but the City Engineer shall have the right to check the gauge to determine its accuracy at any time.

All leaky joints shall be corrected to stop the leakage. Any defective material shall be removed and replaced with sound materials by the Contractor at his own expense. The hydrostatic pressure test shall be repeated until satisfactory to the City Engineer.

**W-11 METHODS OF MEASUREMENT AND PAYMENT (2611.4)**

**W-11.1 FOUNDATION MATERIALS**

Material uses for refilling to pipe foundation grade to assure firm foundation for pipe shall be paid for at the contract unit price per measured cubic yard volume in place. Payment shall be made only for the width of trench and shall not exceed the quantity of material used within the maximum allowable width of trench multiplied by the depth below the bottom of the pipe. Payment shall include cost of excavation and placement.

Unless pay items are included for foundation materials, such cost shall be incidental to the project.

**W-11.2 BASE MATERIAL AND SURFACING**

The payment shall be by the unit price bid per ton for "Aggregate Base, Class 5."

**W-11.3 STREET PATCHING AND REPLACEMENT OF CURB AND GUTTER**

Payment for furnishing, placing, and shaping the patching shall be paid at the unit price per square yard or portion as specified in the proposal for each location.

Payment for furnishing and placing the curb and gutter shall be at the unit price per lineal foot measured along the face of the curb and gutter line.

**W-11.4 AIR RELEASE VALVE ASSEMBLY**

Air release valve assemblies shall be measured by the number of each type installed complete as specified. The quantity measured shall be paid for at the contract unit price per each.

**W-11.5 BLOWOFF VALVE ASSEMBLY**

Blowoff valve assemblies shall be measured by the number of each type installed complete as specified. The quantity measured shall be paid for at the contract unit price per each.

**W-11.6 HYDRANT AND VALVE ASSEMBLY**

Hydrant and valve assembly shall be measured by the number of each type installed complete as specified. The quantity measured shall be paid for at the contract unit price per each.

**W-12 EROSION CONTROL**

Refer to Section 10.0 of the City of Fridley's Supplemental Specifications to Standard Utilities Specifications for Sanitary Sewer and Storm Sewer Installation.

**W-13 TEMPORARY WATER SYSTEM**

The Contractor shall furnish, install, and maintain a temporary water system to provide uninterrupted water service until the permanent system is operational. The Contractor shall size the system as to provide adequate pressure and capacity to the approval of the City Engineer.

The Contractor shall disinfect and flush the temporary system per W-8. The Contractor shall pass the bacteriological test and consult with each resident prior to connecting the temporary water system to the outside sillcock or other.



**CITY ENGINEERS ASSOCIATION OF MINNESOTA**  
*Engineering Our Cities' Futures*

# **CITY ENGINEERS ASSOCIATION OF MINNESOTA**

## **STANDARD SPECIFICATIONS**

**2600 Trench Excavation and Backfill/Surface Restoration**

**2611 Watermain and Service Line Installation**

**2621 Sanitary Sewer and Storm Sewer Installation**

**2631-CIPPS Sewer Pipe Rehabilitation - Cured In Place Pipe Systems**

**2641 – Pipeline Rehabilitation - Pipe Bursting Method**

**2018 Edition**



# TABLE OF CONTENTS

<b>SECTION 2600 – STANDARD SPECIFICATIONS FOR TRENCH EXCAVATION &amp; BACKFILL/SURFACE RESTORATION.....</b>	<b>1</b>
2600.1 DESCRIPTION .....	1
2600.2 MATERIALS .....	1
A Granular Materials .....	1
A1 Granular Material Gradation Classifications .....	1
A2 Granular Material Use Designations .....	2
B Insulation .....	3
C Geotextile Fabric .....	3
2600.3 CONSTRUCTION REQUIREMENTS .....	3
A General Provisions .....	3
A1 Maintenance of Traffic .....	3
A2 Establishing Line and Grade .....	3
A3 Protection of Surface Structures .....	5
A4 Interference of Underground Structures .....	6
A5 Removal of Surface Improvements .....	6
A6 Temporary Service Measures .....	7
B Excavation and Preparation of Trench .....	7
B1 Operational Limitations and Requirements .....	7
B2 Classification and Disposition of Materials .....	8
B3 Excavation Limitations and Requirements .....	9
B4 Sheet piling and Bracing Excavations .....	10
B5 Preparation and Maintenance of Foundations .....	11
B6 Contaminated Materials and Regulated Wastes .....	12
C Trenchless Pipe Installation .....	13
C1 Jacking/Boring .....	13
C2 Directional Boring .....	15
D Placement of Insulation .....	15
E Pipeline Backfilling Operations .....	16
F Restoration of Surface Improvements .....	17
G Maintenance and Final Cleanup .....	17
2600.4 METHOD OF MEASUREMENT .....	18
A Rock Excavation .....	18
B Granular Materials .....	18
C Geotextile Fabric .....	18
D Insulation .....	18
2600.5 BASIS OF PAYMENT .....	19
<b>SECTION 2611 – STANDARD SPECIFICATIONS FOR WATERMAIN AND SERVICE LINE INSTALLATION .....</b>	<b>20</b>
2611.1 DESCRIPTION .....	20
2611.2 MATERIALS .....	22

<b>A</b>	<b>Water Pipe Materials</b> .....	<b>22</b>
<b>A1</b>	<b>Ductile Iron Pipe and Ductile Iron and Gray Iron Fittings</b> .....	<b>22</b>
<b>A2</b>	<b>Polyvinyl Chloride (PVC) Pressure Pipe and Fittings</b> .....	<b>23</b>
<b>A3</b>	<b>Polyethylene (PE) Pressure Pipe and Fittings</b> .....	<b>23</b>
<b>B</b>	<b>Fire Hydrants</b> .....	<b>24</b>
<b>C</b>	<b>Valves and Valve Housing</b> .....	<b>25</b>
<b>C1</b>	<b>Valve Housings</b> .....	<b>25</b>
<b>C2</b>	<b>Gate Valves</b> .....	<b>25</b>
<b>C3</b>	<b>Butterfly Valves</b> .....	<b>26</b>
<b>D</b>	<b>Water Service Pipe and Fittings</b> .....	<b>26</b>
<b>E</b>	<b>Polyethylene Encasement Material</b> .....	<b>27</b>
<b>F</b>	<b>Mechanical Joint Restraints</b> .....	<b>27</b>
<b>G</b>	<b>Mortar</b> .....	<b>27</b>
<b>H</b>	<b>Concrete</b> .....	<b>27</b>
<b>I</b>	<b>Tracer Wire for Non-Conductive Pipe</b> .....	<b>28</b>
<b>2611.3</b>	<b>CONSTRUCTION REQUIREMENTS</b> .....	<b>28</b>
<b>A</b>	<b>Installation of Pipe and Fittings</b> .....	<b>28</b>
<b>A1</b>	<b>Inspection and Handling</b> .....	<b>29</b>
<b>A2</b>	<b>Pipe Laying Operations</b> .....	<b>29</b>
<b>A3</b>	<b>Aligning and Fitting of Pipe</b> .....	<b>30</b>
<b>A4</b>	<b>Blocking and Anchoring of Pipe</b> .....	<b>30</b>
<b>A5</b>	<b>Polyethylene Encasement of Pipeline</b> .....	<b>31</b>
<b>B</b>	<b>Connection and Assembly of Joints</b> .....	<b>32</b>
<b>B1</b>	<b>Ductile Iron Pressure Pipe and Fitting Joints</b> .....	<b>32</b>
<b>B2</b>	<b>Polyvinyl Chloride Pipe Joints</b> .....	<b>33</b>
<b>B3</b>	<b>Polyethylene Pipe Joints</b> .....	<b>33</b>
<b>B4</b>	<b>Tracer Wire for Non-conductive Pipe</b> .....	<b>33</b>
<b>C</b>	<b>Water Service Installations</b> .....	<b>34</b>
<b>C1</b>	<b>Tee Branch Service Lines</b> .....	<b>34</b>
<b>C2</b>	<b>Tapped Service Lines</b> .....	<b>34</b>
<b>D</b>	<b>Setting Valves, Hydrants, Fittings and Specials</b> .....	<b>36</b>
<b>E</b>	<b>Disinfection of Watermains</b> .....	<b>36</b>
<b>F</b>	<b>Electrical Conductivity Test</b> .....	<b>37</b>
<b>G</b>	<b>Hydrostatic Testing of Watermains</b> .....	<b>37</b>
<b>H</b>	<b>Operational Inspection</b> .....	<b>38</b>
<b>2611.4</b>	<b>METHOD OF MEASUREMENT</b> .....	<b>38</b>
<b>A</b>	<b>Water Pipe</b> .....	<b>38</b>
<b>B</b>	<b>Valves</b> .....	<b>38</b>
<b>C</b>	<b>Corporation Stops</b> .....	<b>38</b>
<b>D</b>	<b>Curb Stops</b> .....	<b>39</b>
<b>E</b>	<b>Hydrants</b> .....	<b>39</b>
<b>F</b>	<b>Air Vents</b> .....	<b>39</b>
<b>G</b>	<b>Polyethylene Encasement</b> .....	<b>39</b>
<b>H</b>	<b>Ductile and Gray Iron Fittings</b> .....	<b>39</b>
<b>I</b>	<b>Polyvinyl Chloride or Polyethylene</b> .....	<b>39</b>
<b>J</b>	<b>Access Structures</b> .....	<b>39</b>
<b>2611.5</b>	<b>BASIS OF PAYMENT</b> .....	<b>39</b>

**SECTION 2621 – STANDARD SPECIFICATIONS FOR SANITARY SEWER AND STORM SEWER INSTALLATION .....41**

**2621.1 DESCRIPTION .....41**

**2621.2 MATERIALS .....42**

- A Sewer Pipe and Service Line Materials.....43**
  - A1 Vitrified Clay Pipe and Fittings .....43
  - A2 Ductile Iron Pipe and Ductile Iron and Gray Iron and Fittings .....43
  - A3 Reinforced Concrete Pipe and Fittings .....44
  - A4 Corrugated Steel Pipe and Fittings .....45
  - A5 Polyvinyl Chloride Pipe and Fittings.....45
  - A6 Cast Iron Soil Pipe .....45
  - A7 Acrylonitrile-Butadiene-Styrene Pipe .....46
  - A8 Corrugated Polyethylene Pipe .....46
  - A9 Solid Wall High Density Polyethylene Pipe.....46
  - A10 Fiberglass Reinforced Pipe .....46
  - A11 Polypropylene Pipe .....47
  - A12 Tracer Wire for Non-conductive Pipe .....47
- B Metal Sewer Castings .....48**
- C Precast Concrete Manhole and Catch Basin Sections .....48**
- D Mortar .....49**
- E Concrete .....49**

**2621.3 CONSTRUCTION REQUIREMENTS.....49**

- A Installation of Pipe and Fittings .....49**
  - A1 Inspection and Handling .....49
  - A2 Pipe Laying Operations .....50
  - A3 Connection and Assembly of Joints.....50
  - A4 Bulkheading Open Pipe Ends .....51
  - A5 Tracer Wire .....51
- B Appurtenance Installations .....51**
- C Sewer Service Installations .....52**
- D Manhole and Catch Basin Structures .....53**
- E Sanitary Sewer Leakage Testing .....54**
  - E1 Air Test Method .....54
  - E2 Hydrostatic Test Method .....56
  - E3 Test Failure and Remedy.....57
- F Deflection Test .....57**
  - F1 Test Failure and Remedy.....57
- G Televising .....58**

**2621.4 METHOD OF MEASUREMENT .....58**

- A Sewer Pipe .....58**
- B Manholes .....58**
- C Catch Basins.....58**
- D Outside Drop Connection.....59**
- E Service Connection.....59**
- F Service Pipe.....59**
- G Special Pipe Fittings.....59**
- H Appurtenant Items.....59**

2621.5 BASIS OF PAYMENT .....	59
-------------------------------	----

**SECTION 2631 CIPPS – STANDARD SPECIFICATIONS FOR SANITARY SEWER AND STORM SEWER PIPE REHABILITATION WITH CURED IN-PLACE PIPE SYSTEMS (CIPPS)..... 61**

2631.1 CIPPS DESCRIPTION .....	61
A General .....	61
B Qualifications .....	62
B1 Manufactured Products and Installation .....	62

2631.2 CIPPS MATERIALS .....	63
A General .....	63
A1 CIPPS Fabric Tube .....	63
A2 CIPPS Structural Requirements .....	64
A3 Material Testing Requirements .....	66

2631.3 CIPPS CONSTRUCTION REQUIREMENTS.....	66
A Installation of CIPPS .....	66
A1 Access .....	66
A2 Water Usage .....	66
A3 Cleaning of Sewer Lines .....	67
A4 Bypassing Wastewater .....	67
A5 Inspection of Pipelines .....	67
A6 Line Obstructions .....	68
A7 Public Notification .....	68
A8 Liner Installation.....	68
A9 Resin Impregnation .....	69
A10 Cool Down .....	69
A11 Finishing Operations .....	70
A12 Manhole Connections.....	70
A13 Reconnections of Existing Services.....	71
A14 CIPP Short-Liner .....	71
B TESTING AND INSPECTION .....	72
B1 Testing .....	72
B2 Inspection .....	72
B3 Televising .....	72

2631.4 CIPPS METHOD OF MEASUREMENT .....	73
--	----

2631.5 CIPPS BASIS OF PAYMENT .....	73
-------------------------------------	----

**SECTION 2641 – STANDARD SPECIFICATIONS FOR PIPELINE REHABILITATION BY PIPE BURSTING ..... 74**

2641.1 DESCRIPTION .....	74
A General .....	74

2641.2 QUALIFICATIONS .....	74
-----------------------------	----

2641.3 MATERIALS .....	74
------------------------	----

<b>2641.4 SUBMITTALS.....</b>	<b>75</b>
<b>2641.5 DELIVERY, STORAGE, AND HANDLING.....</b>	<b>75</b>
<b>2641.6 LICENSE AGREEMENTS .....</b>	<b>75</b>
<b>2641.7 CONSTRUCTION REQUIREMENTS.....</b>	<b>76</b>
<b>2641.8 TESTING AND INSPECTION.....</b>	<b>78</b>
<b>2641.9 METHOD OF MEASUREMENT .....</b>	<b>78</b>
<b>2641.10 BASIS OF PAYMENT.....</b>	<b>78</b>

## **SECTION 2600 – STANDARD SPECIFICATIONS FOR TRENCH EXCAVATION & BACKFILL/SURFACE RESTORATION**

### **2600.1 DESCRIPTION**

This work shall consist of excavation, trenching, backfilling, and restoration of existing surfaces for the construction of underground utilities.

The use of the term "Plans, Specifications and Special Provisions" within this specification shall be construed to mean those documents which compliment, modify, or clarify these specifications and are an enforceable component of the Contract Documents.

All references to MnDOT Specifications shall mean the latest published edition of the Minnesota Department of Transportation "Standard Specifications for Construction", and all supplements and amendments thereto, published prior to the date of advertisement for bids.

All reference to other Specifications of AASHTO, ASTM, ANSI, AWWA, etc. shall mean the latest published edition available on the date of advertisement for bids.

### **2600.2 MATERIALS**

#### **A Granular Materials**

Granular materials furnished for foundation, bedding, encasement, backfill, or other purposes as may be specified shall consist of any natural or synthetic mineral aggregate such as sand, gravel, crushed rock, crushed stone, or slag that shall be so graded as to meet the gradation requirements specified herein for each particular use by the material manufacturer or as indicated in the Plans, Specifications, or Special Provisions.

#### **A1 Granular Material Gradation Classifications**

Granular materials furnished for use in Foundation, Bedding, Encasement, or Backfill construction shall conform to the following requirements:

Foundation materials shall have one hundred percent (100%) by weight passing the one and one-half inch (1 1/2") sieve and a maximum of ten percent (10%) by weight passing the No. 4 sieve. Not less than fifty percent (50%) of the material by weight that is retained on the No. 4 sieve shall have one (1) or more crushed faces. Hard, durable crushed carbonate quarry rock may be used for Foundation materials.

Bedding and encasement materials for flexible pipe shall meet the requirements of MnDOT Specification 3149.2B1, Granular Material, except that one hundred percent (100%) by weight shall pass the one-inch (1") sieve.

Backfill materials shall consist of suitable existing trench materials, except as otherwise specified in the Special Provisions. Suitable material shall be defined as a mineral soil free of foreign materials (rubbish, organics, and debris), frozen clumps, oversize stone, rock, concrete or bituminous chunks, and other unsuitable materials that may damage the pipe, prevent thorough compaction, or increase the risks of settlement.

A gradation report, certified by an approved independent testing laboratory, of the proposed granular materials shall be furnished to the Engineer before any of the granular materials are delivered to the project.

**A2 Granular Material Use Designations**

Granular materials provided for Foundation, Bedding, Encasement, or Backfill use as required by the Plans, Specifications, and Special Provisions, either as part of the pipe item work unit or as a separate contract item, shall be classified as to use in accordance with the following:

Material Use	Zone Designation
Granular Foundation	Placed below the bottom of pipe grade as replacement for unsuitable or unstable soils, to achieve improved foundation support.
Granular Bedding	Placed below the pipe midpoint, prior to pipe installation, to facilitate proper shaping and to achieve uniform pipe support. For flexible pipe installation, placed below the pipe midpoint to a point six inches (6") below the bottom of pipe or twenty five percent (25%) of the diameter below the pipe, whichever is greater.
Granular Encasement	Placed below an elevation one foot above the top of pipe, after pipe installation, for protection of the pipe and to assure proper filling of voids or thorough consolidation of backfill.
Granular Backfill	Placed below the surface base course, if any, as the second stage of backfill, to minimize trench settlement and provide support for surface improvements.

In each case above, unless otherwise indicated, the lower limits of any particular zone shall be the top surface of the next lower course as constructed. The upper limits of each zone are established to define variable needs for material gradation and compaction or void content, taking into consideration the sequence of construction and other conditions. The material use and zone designations described above shall only serve to fulfill the objectives and shall not be construed to restrict the use of any particular material in other zones where the gradation requirements are met.

## **B Insulation**

Insulation shall be extruded rigid board material having a thermal conductivity of 0.23 BTU/hour/square foot/degree Fahrenheit/per inch thickness, maximum, at 40°F mean, a comprehensive strength of thirty-five (35) psi minimum, and water absorption of one quarter percent (0.25%) by volume maximum. Unless otherwise specified in the Plans, Specifications, or Special Provisions, board dimensions shall measure eight feet (8') long, two or four feet (2' or 4') wide, and one (1), one and one half (1-1/2), two (2), or three (3) inches thick.

## **C Geotextile Fabric**

Geotextile fabric shall meet the requirements of MnDOT Specification 3733 and be used as required by the Plans, Specifications, and Special Provisions.

## **2600.3 CONSTRUCTION REQUIREMENTS**

### **A General Provisions**

#### **A1 Maintenance of Traffic**

Whenever work interferes with the flow of traffic along a roadway, the Contractor shall provide traffic control signing and public safety in accordance with the provisions Minnesota Manual on Uniform Traffic Control Devices (current edition and all amendments), MnDOT Specifications 1404 and 1710, and the Special Provisions. Neither road closures nor detours shall be permitted unless specified in the Special Provisions or authorized by the Engineer. Where road closures or detours are permitted by the Engineer, the Engineer shall determine the appropriate agencies, boards, or departments the Contractor must notify prior to taking the action and the proper advance notice to be provided to each body.

Compliance with this requirement shall not be construed to relieve the Contractor from the responsibility of notifying agencies or institutions whose services may be predicated upon a roadway being opened to traffic or whose services would be hindered if a roadway is closed to traffic. Such agencies or institutions shall include, but not be limited to, the police department, the fire department, municipal bus service, school bus service, and ambulance service, mail delivery, and waste hauler services. The Contractor shall keep the required agencies informed of changing traffic patterns and detour situations.

#### **A2 Establishing Line and Grade**

The primary line and grade will be established by the Engineer. For trench installation, line and grade stakes will be set parallel to the proposed pipeline at an appropriate offset therefrom as will best serve the Contractor's operations wherever practical. For tunnel installation, line and grade stakes will be set directly above the proposed pipeline setting.

The Contractor shall arrange operations to avoid unnecessary interference with the establishment of the primary line and grade stakes and shall render whatever assistance may be required by the Engineer in accomplishing the staking. The Contractor shall be responsible for preservation of the primary stakes and, if negligent in providing necessary protection, shall bear the full cost of any re-staking.



The Contractor shall be solely responsible for the correct transfer of the primary line and grade to all working points and for construction of the work to the prescribed lines and grades as established by the Engineer.

Unless otherwise specified in the Plans, Specifications, and Special Provisions the watermain shall generally be placed with the minimum specified cover. However, a greater depth may be required to avoid conflicts with other utilities and obstructions. Installation of watermain and services to a depth deeper than specified shall be considered incidental with no additional compensation allowed therefore.

The existing grade shown on the plans is approximate. Modification of the pipe location or differences in existing elevation shall not be cause for additional compensation.

In areas where direct conflicts arise between watermain and water services, with storm sewer, sanitary sewer, sanitary sewer services, sewer forcemains, septic tanks, or subsoil treatment systems, the following shall apply:

Watermain and services located near sewer forcemains:

A minimum of ten feet (10') of separation, measured horizontally between the outer surfaces of the pipes is required.

If ten feet (10') of separation cannot be provided, an approved additional measure of containment must be provided for either the watermain or the sewer forcemain.

Watermain and services located near septic tanks, or subsoil treatment systems:

A minimum of ten feet (10') measured horizontally between the outer surfaces of the watermain, tank and subsoil treatment system is required.

Watermain and services located near gravity sanitary and storm sewers:

A minimum of ten feet (10') measured horizontally between the outer surfaces of the pipes is required.

In locations where local conditions prevent the required separation indicated above (due to the presence of rock, buildings, other significant obstructions), the watermain may be laid closer to gravity sewer if **one** (1) of the following conditions is met:

The bottom of the watermain is laid at least eighteen inches (18") above the top of the sewer on a separate shelf; or

The sewer is constructed of materials and with joints that are equivalent to watermain standards of construction and is pressure tested to assure water tightness prior to backfilling.

Watermain and services crossing gravity sanitary and storm sewers:

A minimum vertical separation of eighteen inches (18") must be provided between the outer surfaces of the pipes, with preference that the watermain cross above the sewer, wherever possible.

One full length of water pipe shall be located so both joints will be as far from the sewer as possible.

Watermain above-water crossings:

The pipe shall be adequately supported and anchored, protected from vandalism, damage and freezing, and accessible for repair or replacement.

Watermain underwater crossings:

A minimum cover of five feet (5') shall be provided over the pipe unless otherwise approved by the Department of Health. When crossing water courses which are greater than fifteen feet (15') in width, the following shall be provided:

1. The pipe shall be of special construction, having flexible, restrained or welded watertight joints
2. Valves shall be provided at both ends of water crossings so that the section can be isolated for testing or repair; the valves shall be easily accessible, and not subject to flooding
3. Permanent taps or other provisions to allow insertion of a small meter to determine leakage and obtain water samples on each side of the valve closest to the supply source.

### **A3 Protection of Surface Structures**

All surface structures and features located outside the permissible excavation limits for underground installations, together with those within the construction areas which are indicated in the Plans as being saved, shall be properly protected against damage and shall not be disturbed or removed without approval of the Engineer. Within the construction limits, as indicated on the plans or as directed by the Engineer, the removal of improvements such as pavement, curb, curb & gutter, walks, turf, etc., shall be subject to equivalent acceptable replacement after completion of underground work, with all expense of removal and replacement being borne by the Contractor to the extent that separate compensation is not specifically provided for in the Contract.

Obstructions such as street signs, guard posts, small culverts, mailboxes, and other items of prefabricated construction may be temporarily removed during construction provided that essential service is maintained in a relocated setting as approved by the Engineer and that nonessential items are properly stored for the duration of construction. Upon completion of the underground work, all such items shall be replaced in their proper setting at the sole expense of the Contractor to the extent that separate compensation is not specifically provided for in the Contract.

The Contractor shall be responsible for protection of existing overhead utilities and poles. This shall include arranging with the utility owner and arrange paying the utility for holding poles that will be close to the edge of any trench. Holding of poles and repair of any damage to these facilities shall be considered incidental to the project with no additional compensation allowed. If relocation or removal of these facilities is required, the Owner will contact the concerned utility owner and arrange and pay for the relocation or removal at no additional expense to the Contractor.

In the event of damage to any surface improvements, either privately or publicly owned, in the absence of construction necessity, the Contractor will be required to replace or repair the damaged property to the satisfaction of the Engineer and without cost to the Owner.

#### **A4 Interference of Underground Structures**

When any underground structure interferes with the planned placement of the pipeline or appurtenances to such an extent that alterations in the work are necessary to eliminate the conflict or avoid endangering effects on either the existing or proposed facilities, the Contractor shall immediately notify the Engineer and the Owner of the affected structure. When any existing facilities are endangered by the Contractor's operations, the Contractor shall cease work at the site and take such precautions as may be necessary to protect the in-place structures until a decision is made as to how the conflict will be resolved.

Without specific authorization from the Engineer, no utility service shall be disrupted, nor shall any change be made in either the existing structures or the planned installations to overcome the interference. Alterations in existing facilities will be allowed only to the extent that service will not be curtailed and then only when the encroachment or relocation will satisfy all applicable regulations and conditions.

Wherever alterations are required as a result of unforeseen underground interferences not due to any fault or negligence of the Contractor, the Engineer will issue a written order covering any additional or extra work involved and specifying the revised basis of payment, if any. Any alterations made strictly for the convenience of the Contractor, shall be subject to prior approval and shall be at the Contractor's expense. No extra compensation will be allowed for delays caused by the interference of underground structures.

#### **A5 Removal of Surface Improvements**

Removal of surface improvements in connection with trench excavation shall be limited to actual needs for installation of the pipeline and appurtenances, based on the allowable trench widths and any other controls imposed in connection with the work. Removal operations shall be coordinated effectively with the excavation and installation operations as will cause the least practical disruption of traffic or inconvenience to the public. The debris resulting from removals shall become the property of the Contractor and shall be disposed of by the Contractor in accordance with MnDOT Specification 2104 and the Special Provisions. Removal debris shall not be deposited at locations that will block access to fire hydrants, private driveways, or other essential service areas, nor obstruct surface drainage. Removal and final disposal of debris shall be accomplished as a single operation wherever possible and, in any event, the debris shall be removed from the site before starting the excavating operations.

Removal of concrete or bituminous structures shall be by methods producing clean-cut breakage to pre-scored lines as will preserve the remaining structure without damage. Removal equipment shall not be operated in a manner that will cause damage to the remaining structure or adjoining property. Where not removed to an existing joint, concrete structures shall be sawed along the break lines to a minimum depth of one-third (1/3) of the structure depth.

Any reusable materials generated during the work, such as aggregate, sod, topsoil, shall be segregated from other waste materials and be stockpiled so as to maintain suitability and permit proper reuse.

The use of drop weight equipment for breaking pavement will be allowed to the extent that the Contractor shall assume full responsibility for any damages caused thereby. The pavement breaking operation shall not be allowed to become a nuisance to the public or a source of damage to underground or adjacent structures. The Engineer reserves the right to order discontinuance of drop weight breaking operations at any time.

## **A6 Temporary Service Measures**

While any open excavations are maintained, the Contractor shall have available a supply of steel plates suitable for temporary bridging of open trench sections where either vehicular or pedestrian traffic must be maintained. Use of the plates shall be as directed or approved by the Engineer and where installed they shall be secured against possible displacement and be replaced with the permanent structure as soon as possible.

## **B Excavation and Preparation of Trench**

### **B1 Operational Limitations and Requirements**

Trench excavation must conform to all local, state and federal requirements. All work must be confined to the limits of the construction and to easements and right of way as indicated on the plans. The Contractor shall install at his expense the necessary trench support to meet the varying soil conditions and to protect existing structures and property. The trench shall be drained to provide stable excavation and permit the pipe to be laid in a dry trench.

Excavating operations shall proceed only so far in advance of pipe laying as will satisfy the needs for coordination of work and permit advance verification of unobstructed line and grade as planned, consistent with the Contractors methods and scheduling. Where interference with existing structures is possible or in any way indicated, and where necessary to establish elevation or direction for connections to in-place structures, the excavating shall be done at those locations in advance of the main operation so actual conditions will be exposed in sufficient time to make adjustments without resorting to extra work or unnecessary delay.

Wherever possible, excavated materials shall be placed in areas that will not block existing vehicle and pedestrian traffic and drainage ways. The Contractor shall review proposed methods of operation with the Engineer prior to beginning the work.

The Contractor shall backfill all trenches at the end of each work day, or upon written authorization of the Engineer, shall provide another approved method of protecting the trench area while work is not being performed.

All installations shall be accomplished by open trench with the exception that boring, jacking and tunnel construction methods shall be employed where specifically required by the Plans, Specifications, or Special Provisions.

The excavating operations shall be conducted so as to carefully expose all existing underground structures without damage. Wherever the excavation extends under or approaches so close to an existing structure as to endanger it in any way, precautions and protective measures shall be taken as necessary to preserve the structure and provide temporary support. Hand methods of excavating shall be utilized to probe for and expose such critical or hazardous installations as gas pipe, power and communication cables, watermain, gravity and pressure sewers, and respective service pipes.

The Engineer shall be notified of any need for blasting to remove materials which cannot be broken up mechanically, and there shall be no blasting operations conducted until the Engineer's approval has been secured. Blasting will be allowed only when proper precautions are taken to protect life and property, and then shall be restricted as the Engineer directs. The hours of blasting operations shall be set by the Owner. The Contractor shall assume full responsibility for any damages caused by blasting, regardless of the requirements for notification and approval. The Contractor shall secure any required permits for blasting and shall conduct blasting operations in conformance with all applicable local, state and federal laws, regulations, and ordinances.

## **B2 Classification and Disposition of Materials**

Excavated materials will be classified for payment only when specifically provided in the Special Provisions, or the Proposal. All other materials encountered in the excavations will be considered incidental to utility construction, with no additional compensation provided thereto.

Miscellaneous excavated materials that are not specifically identified for payment in the Special Provisions or Proposal, exceed one (1) cubic yard in volume, cannot be re-used within the project limits, and in the opinion of the Engineer requires special means for handling and disposal, may be considered for payment through supplemental agreement as extra work. Miscellaneous excavated materials include but are not limited to organic soils, rubble, wood debris, boulder stone, masonry, concrete fragments, and metals.

Rock excavation shall be defined to include all hard, solid rock in ledge formation, bedded deposits and unstratified masses; all natural conglomerate deposits so firmly cemented as to present all the characteristics of solid rock; and any boulder stone, masonry or concrete fragments exceeding one (1) cubic yard in volume. Materials such as shale, hard pan, soft or disintegrated rock which can be dislodged with a hand pick or removed with a power operated excavator will not be classified as Rock Excavation.

Excavated materials will be classified for reuse as being either Suitable or Unsuitable for backfill or other specified use, subject to selective controls. All suitable materials shall be reserved for backfill to the extent needed, and any surplus remaining shall be utilized for other construction on the project as may be specified or ordered by the Engineer. To the extent practicable, granular materials and topsoil shall be segregated from other materials during the excavating and stockpiling operations so as to permit best use of the available materials at the time of backfilling. Unless otherwise specified in the Plans, Specifications, and Special Provisions, material handling as described above shall be considered incidental with no additional compensation provided.

All excavated materials reserved for backfill or other use on the project shall be stored at locations approved by the Engineer that will cause a minimum of inconvenience to public travel, adjacent properties, and other special interests. The material shall not be deposited so close to the edges of the excavations in a manner that could create hazardous conditions, nor shall any material be placed so as to block the access to emergency services. All materials considered unsuitable by the Engineer, for any use on the project, shall be immediately removed from the project and be disposed of as arranged for by the Contractor with no additional compensation.

### **B3 Excavation Limitations and Requirements**

Trench excavating shall be to a depth that will permit preparation of the foundation as specified and installation of the pipeline and appurtenances at the prescribed line and grade, except where alterations are specifically authorized. Trench widths shall be sufficient to permit the pipe to be laid and joined properly and the backfill to be placed and compacted as specified. Extra width shall be provided as necessary to permit convenient placement of sheeting and shoring and to accommodate placement of appurtenances.

Excavations shall be extended below the bottom of structures as necessary to accommodate any required Granular Foundation material. When rock or unstable foundation materials are encountered at the established grade, additional materials shall be removed as specified or directed by the Engineer to produce an acceptable foundation. Unless otherwise indicated or directed, rock shall be removed to an elevation at least six inches (6") below the bottom surface of the pipe barrel and below the lowest projection of flange and bell/spigot joint. All excavations below grade shall be to a minimum width equal to the outside pipe diameter plus two feet (2'). Rock shall be removed to such additional horizontal dimensions as will provide a minimum clearance of six inches (6") on all sides of appurtenant structures such as valves, housings, access structures, etc.

Where no other grade controls are indicated or established for the pipeline, the excavating and foundation preparations shall be such as to provide a minimum cover over the top of the pipe as specified. Trench widths shall allow for at least six inches (6") of clearance on each side of the flange and bell/spigot joint. The maximum allowable width of the trench at the top of pipe level shall be the outside diameter of the pipe plus two feet (2'), subject to the considerations for alternate pipe loading set forth below. The width of the trench at the ground surface shall be held to a minimum to prevent unnecessary destruction of the surface structures.

The maximum allowable trench width at the top of pipe level may be exceeded only by approval of the Engineer, after consideration of pipe strength and loading relationships. Any alternate proposals made by the Contractor shall be in writing, giving the pertinent soil weight data and proposed pipe strength alternate, at least seven (7) days prior to the desired date of decision. Approval of alternate pipe designs shall be with the understanding that there will be no extra compensation allowed for any increase in material or construction costs.

If the trench is excavated to a greater width than that authorized, the Engineer may direct the Contractor to provide a higher class of bedding and/or a higher strength pipe than that required by the Plans, Specifications, and Special Provisions in order to satisfy design requirements, without additional compensation.

Excess excavated materials generated by utility construction without a specified use on the project site, shall become the property of the Contractor and disposed of offsite. Offsite disposal of excess excavated materials is considered incidental to the construction with no additional compensation allowed thereto.

The use of granular foundation materials shall not be used as an aid to facilitate installation of pipe in wet soil conditions. Use of these materials in this manner in lieu of providing adequate dewatering measures shall be considered incidental to the construction with no additional compensation allowed therefore.

#### **B4 Sheeting and Bracing Excavations**

All trench excavations that require slope support shall be sheeted, shored, and braced in a manner that will meet all requirements of the applicable safety codes and regulations; comply with any specific requirements of the Contract; and prevent disturbance or settlement of adjacent surfaces, foundations, structures, utilities, and other properties. Any damage to the work under contract, to adjacent structures, or other property, caused by settlement, water or earth pressures, slides, cave-ins, or other causes due to the failure or lack of sheeting, shoring, or bracing, through negligence or fault of the Contractor in any manner shall be repaired at the Contractor's expense and without delay.

The Plans, Specifications, and Special Provisions may require special precautions to protect life and property. The Engineer may order other precautions when excavation conditions appear to warrant additional measures. Failure of the Engineer to order correction of improper or inadequate sheeting, shoring, or bracing shall not relieve the Contractor's responsibilities for protection of life, property, and the work.

The Contractor shall assume full responsibility for proper and adequate placement of sheeting, shoring, and bracing, to prevent displacement. Bracing shall be so arranged as to provide ample working space and without increase of stress or strain on the in-place structures to any extent that may cause damage.

Sheeting, shoring and bracing materials shall be removed only when and, in such manner, as will assure adequate protection of the in-place structures and prevent displacement of supported grounds. Sheeting and bracing shall be left in place only as required by the Plans, Specifications, and Special Provisions or ordered by the Engineer. Otherwise, sheeting and bracing may be removed as the backfilling reaches the level of respective support. Wherever sheeting and bracing is left in place, the upper portions shall be cut and removed to an elevation of three feet (3') or more below the established surface grade or as the Engineer may direct.

All costs of furnishing, placing and removing sheeting, shoring, and bracing materials, including the value of materials left in place as required by the Contract, shall be included in the prices bid for pipe installation and will not be compensated for separately. When sheeting, shoring, or bracing materials are left in place by written order of the Engineer, in the absence of specific requirements of the Contract, payment will be made for those materials by supplemental agreement.

## **B5 Preparation and Maintenance of Foundations**

Foundation preparations shall be conducted as necessary to produce a stable foundation and provide continuous and uniform pipe bearing between bell holes. The initial excavating or backfilling operations shall produce a subgrade level slightly above finished grade as will permit hand shaping to finished grade by trimming of high spots and without the need for filling of low spots to grade. Final subgrade preparations shall be such as to produce a finished grade at the centerline of the pipe that is within three hundredths of a foot (0.03') of a straight line between pipe joints and to provide bell excavation at each joint as will permit proper joining of pipe and fittings.

In excavations made below grade to remove rock or unstable materials, the backfilling to grade shall be made with available suitable materials unless placement of Granular Foundation or Bedding material is specified or is ordered by the Engineer. Placement of the backfill shall be in relatively uniform layers not exceeding eight inches (8") in loose thickness. Each layer of backfill shall be compacted thoroughly, by means of approved mechanical compaction equipment, as will produce uniform pipe support throughout the full pipe length and facilitate proper shaping of the pipe bed.

It shall be the Contractor's responsibility to notify the Engineer of changing soil conditions which may be of poor bearing capacity and when organic soils are encountered. Where utilities are placed on unstable soils without notification of the Engineer, the Contractor shall be responsible for all repairs and correction of the installation without further compensation.

Care shall be taken during final subgrade shaping to prevent any over-excavation. Should any low spots develop, they shall only be filled with approved material, which shall have optimum moisture content and be compacted thoroughly without additional compensation to the Contractor. The finished subgrade shall be maintained free of water and shall not be disturbed during pipe lowering operations except as necessary to remove pipe slings. The discharge of trench dewatering pumps shall be directed to natural drainage channels or storm water drains. Draining trench water into sanitary sewers or combined sewers will not be permitted.

The Contractor shall install and operate a dewatering system of wells or points to maintain pipe trenches free of water whenever necessary or as directed by the Engineer. Unless otherwise specified in the Plans, Specifications, and Special Provisions such work shall be considered incidental.

All costs of excavating below grade and placing foundation or bedding aggregates as required shall be included in the bid prices for pipe items to the extent that the need for such work is indicated in the Contract provisions and the Proposal does not provide for payment under separate Contract Items. Any excavation below grade and any foundation or bedding aggregates required by order of the Engineer in the absence of Contract requirements will be compensated for separately.

If examination by the Engineer reveals that the need for placement of foundation aggregate was caused by the Contractor's manipulation of the soils in the presence of excessive moisture or lack of proper dewatering, the cost of the corrective measures shall be borne by the Contractor.



## **B6 Contaminated Materials and Regulated Wastes**

If during the course of the Project, the Contractor unexpectedly encounters any of the following conditions indicating the possible presence of contaminated soil, contaminated water, or regulated waste, the Contractor shall immediately stop work in the vicinity, and notify the Engineer.

At the direction of the Engineer, a documented inspection and evaluation will be conducted prior to the resumption of work. The Contractor shall not resume work in the suspected area without authorization by the Engineer.

Indicators of contaminated soil, groundwater or surface water include, but are not limited to the following:

- (1) Odor including gasoline, diesel, creosote (odor of railroad ties), mothballs, or another chemical odor.
- (2) Soil stained green or black (but not because of organic content), or with a dark, oily appearance, or any unusual soil color or texture.
- (3) A rainbow color (sheen) on surface water or soil.

Indicators of regulated wastes include, but are not limited to the following:

- (1) Cans, bottles, glass, scrap metal, wood (indicators of solid waste and a potential dump site).
- (2) Concrete and asphalt rubble (indicators of demolition waste).
- (3) Roofing materials, shingles, siding, vermiculite, floor tiles, transite or any fibrous material (indicators of demolition waste that could contain asbestos, lead or other chemicals).
- (4) Culverts or other pipes with tar-like coating, insulation or transite (indicators of asbestos).
- (5) Ash (ash from burning of regulated materials may contain lead, asbestos or other chemicals).
- (6) Sandblast residue (could contain lead).
- (7) Treated wood including, but not limited to products referred to as green treat, brown treat and creosote (treated wood disposal is regulated).
- (8) Chemical containers such as storage tanks, drums, filters and other containers (possible sources of chemical contaminants).
- (9) Old basements with intact floor tiles or insulation (could contain asbestos), sumps (could contain chemical waste), waste traps (could contain oily wastes) and cesspools (could contain chemical or oily wastes).

Discovery of contaminated soil, contaminated water, or regulated waste on State right of way, State property, and State funded projects shall be handled in accordance with guidance procedures of the MNDOT Office of Environmental Services (OES) and the MPCA requirements for materials handling, disposal, re-use and remediation.

Discovery of contaminated soil, contaminated water, or regulated waste on projects or properties that are not under the ownership or financed by the State shall be handled in accordance with guidance procedures of the MPCA requirements for materials handling, disposal, re-use and remediation.

## **C Trenchless Pipe Installation**

The Contractor shall inspect and verify soil conditions as necessary in order to determine the type of construction to employ. Natural and/or manmade obstructions may be encountered in the soil. These contract documents do not warrant the nature or condition of the soils, and do not warrant that natural or manmade obstructions will not be encountered, nor guarantee the extent to which rocks, boulders, or other obstructions, regardless of size, may be encountered during boring operations. The Contractor shall not be entitled to additional compensation for any natural or manmade obstructions encountered during trenchless construction.

The Contractor shall be responsible for protecting all existing utilities within the construction limits.

### **C1 Jacking/Boring**

The terms "auger", "boring", "jack", "jacking", and "tunneling" in the proposal, specifications, and plans refers only to trenchless construction.

The minimum diameter of the casing pipe shall be four inches (4") greater than the outside diameter of the bell of the carrier pipe.

The Contractor shall prevent excavated materials from flowing back into the excavation during the trenchless construction. This shall include the use of a shield conforming to the size and shape of the casing that will prevent materials from flowing into the leading edge of the casing. The machine used shall be capable of controlling line and grade and shall conform to the size and shape of the casing pipe.

No jacking/augering of pipe will be allowed below the water table unless the water table has been lowered sufficiently to keep the water below the pipe being installed. The use of water under pressure (jetting) or puddling will not be permitted to facilitate jacking/augering operations.

If any installation is augered, the head shall be approved by the Engineer and the auger shall be located six inches (6") behind the lead edge of the casing or carrier pipe.

The jacking system shall be provided with an integral grout pipe and casing pipe. A one-inch (1") grout pipe shall be tack welded to the front edge of the first length of casing pipe. The grout pipe shall be extended with the casing pipe, but not fastened to the casing pipe during the remaining jacking operations. After the pipes are through to the receiving pit, the grout pipe shall be cut free from the casing pipe. The grout pipe shall be pulled back through the embankment applying positive piston pressure on the grout along the outside of the casing pipe throughout the pulling operation. A cement slurry grout mix with as little water as possible shall be used. Bentonite shall not be used to fill voids. The Engineer shall approve grout and backfill material prior to placement of any material.

Deviation from the pipe grade, as provided by the Engineer, in excess of five tenths of a percent (0.05%) may be cause for removal and relaying of the pipe by the Contractor with no additional compensation allowed therefore.

If a void develops, the jacking or boring operation shall be stopped immediately and the void shall be filled by an approved method.

The Contractor shall take the following precautions when boring:

Extend casing through entire distance bored.

Check grade and alignment after each casing section is installed.

Coordinate operations to provide continuous support to surrounding earth materials.

Excavation shall be carried on in such a manner as to provide adequate support to surface structures and roads above and adjacent to the boring and not create any hazards to overhead traffic and other activities.

These contract documents do not guarantee the extent to which rocks, boulders, or other obstructions, regardless of size, may be encountered during boring operations. No extra compensation will be made for removal of rocks, boulders or other natural or manmade obstructions encountered during trenchless construction or excavation.

All voids caused by boring shall be filled by pressure grouting. The grout material shall consist of sand cement slurry of at least two (2) sacks of cement per cubic yard and a minimum of water to assure satisfactory placement. All slurry shall be pre-approved by the Engineer prior to use by the Contractor.

The Contractor shall take the following precautions when jacking:

The jacking machine shall be capable of controlling line and grade.

Progressively push carrier pipe through completed casing.

Strap two (2) wooden saddle blocks to each pipe length to provide support at regular intervals.

Center carrier pipe in casing at all times.

Seal each end of the casing with a concrete block and mortar bulkhead with PVC filler and vent pipes at opposite ends.

Fill the annular space between casing and carrier pipe with dry blown sand. Space shall be considered filled when dry sand blows out of the vent pipe at the opposite end of casing pipe.

Seal the filler and vent pipes after the sand has been deposited.

The location, size, and configuration of all jacking pits shall be subject to approval of the Engineer.

## **C2 Directional Boring**

Direction boring/drilling installation shall be accomplished where required on the Plans or in the Special Provisions to minimize disturbance of existing surface improvements. The installer shall have a minimum of five (5) years of experience in this method of construction and have successfully installed at least ten thousand feet (10,000') of eight inch (8") or larger diameter pipe to specified grades. The field supervisor employed by the Contractor shall have at least five (5) years of experience and shall be at the site at all times during the boring/drilling installation.

The Contractor shall submit boring/drilling pit locations to the Engineer before beginning construction. Boring pits may be located within roadway right-of-way and easements. Any other boring pit locations that may be desired by the Contractor for boring or other uses shall be the responsibility of the Contractor to attain authorization, including use of private property.

Unless otherwise provided in the Special Provisions, the Contractor shall be compensated for the restoration work only within the areas at the connection points, or other locations as may be approved by the Engineer. The Contractor shall be responsible for repairs, without compensation, for any other repair areas, including pit/boring points and areas above the drilled pipe where drilling fluid pressure may have caused heaving or damage to pavement and other surfaces.

The drilling equipment shall be capable of placing the pipe as shown on the plans. The installation shall be by a steerable drilling tool capable of installing continuous runs of pipe between appurtenances such as valves, manholes, etc., without intermediate pits. The guidance system shall be capable of installing pipe within one and one-half inch (1 ½") of the plan vertical dimensions and two inches (2") of the plan horizontal dimensions. The Contractor shall remove and reinstall pipes which vary in depth and alignment from these tolerances.

Pull back forces shall not exceed the allowable pulling forces for the pipe being installed. Drilling fluid shall be a mixture of water and bentonite clay and shall be suitable for existing soil conditions. Disposal of excess fluid and spoils shall be the responsibility of the Contractor.

### **D Placement of Insulation**

Rigid insulation board shall be placed within the pipe encasement zone, six inches (6") above the pipe.

Insulation boards shall be placed with the long dimension parallel to the centerline of the pipe. Boards shall be placed in a single layer with tight joints. No continuous joints or seams shall be placed directly over the pipe. If two (2) or more layers of insulation boards are used, each layer shall be placed to cover the joints of the layer immediately below.

The Contractor shall exercise caution to ensure that all joints between boards are tight during placement and backfilling with only extruded ends placed end to end or edge to edge.

Backfill material shall be placed in such a manner that construction equipment does not operate directly on the insulation and compacted with equipment which exerts a contact pressure of less than eighty (80) psi.

## **E Pipeline Backfilling Operations**

All pipeline excavations shall be backfilled to restore preexisting conditions as the minimum requirement, and fulfill all supplementary requirements indicated in the Plans, Specifications, and Special Provisions. The backfilling operations shall be started as soon as conditions will permit on each section of pipeline, so as to provide continuity in subsequent operations and restore normal public service as soon as practicable. All operations shall be pursued diligently, with proper and adequate equipment, to assure acceptable results.

The backfilling shall be accomplished with the use of Suitable Materials selected from the excavated materials to the extent available and practical. Should the materials available within the trench section be unsuitable or insufficient, the required additional materials shall be furnished from outside sources as provided in the Special Provisions, or as arranged otherwise through supplemental agreement.

Backfill material selection shall be such as to make the best and fullest utilization of what is available, taking into consideration particular needs of different backfill zones. Material containing stone, rock, or chunks of any sort shall only be utilized where and to the extent there will be no detrimental effects. Placement of backfill material containing stones, boulders, chunks, greater than eight inches (8") in any dimension shall not be allowed.

All flexible pipe shall be bedded in accordance with ASTM Specification D2321, "Standard Practice for Underground Installation of Thermoplastic Pipe for Sewers and Other Gravity Flow Applications". Where existing soils do not meet the requirements of bedding and encasement materials, the Contractor shall furnish the required granular materials. Placement and compaction of bedding and encasement materials around the pipe shall be considered incidental to the installation of the pipe.

Compaction of materials placed within the pipe bedding and encasement zones shall be accomplished with portable or hand equipment methods, so as to achieve thorough consolidation under and around the pipe and avoid damage to the pipe. Above the cover zone material, the use of heavy roller type compaction equipment shall be limited to safe pipe loading.

Backfill materials shall be carefully placed in uniform loose thickness layers up to twelve inches (12") thick spread over the full width and length of the trench section to provide simultaneous support on both sides of the pipeline. Granular backfill may be placed in layers up to twelve inches (12") above an elevation one foot (1') above the top of the pipe.

Each layer of backfill material shall be compacted effectively, by approved mechanical or hand methods, until there is no further visual evidence of increased consolidation or the density of the compacted layer conforms to the density requirements specified in the Special Provisions. Compaction of each layer shall be completed acceptably before placing material for a succeeding layer thereon. The manner of placement, compaction equipment, or procedure effectiveness shall be subject to approval of the Engineer.

All surplus or waste materials remaining after completion of the backfilling operations shall be disposed of in an acceptable manner within twenty-four (24) hours after completing the backfill work on each particular pipeline section. Disposal at locations within the project limits shall be as specified, or as approved by the Engineer; otherwise, disposal shall be accomplished outside the project limits at the Contractor's discretion. The backfilling and surplus or waste disposal operations shall be a part of the work required under the pipeline installation items, without until final cleanup.

Compaction of backfill within Roadbed areas shall meet the density requirements of MnDOT Specification 2105.3 F1. Compaction of backfill in all other areas shall be as required in the Special Provisions.

Until expiration of the guarantee period, the Contractor shall assume full responsibility and expense for all backfill settlement and shall refill and restore the work as directed to maintain an acceptable surface condition, regardless of location. All additional materials required shall be furnished without cost to the Owner.

Any settlement of road surfaces placed under this Contract and that are within the guarantee period that are in excess of one inch (1"), as measured by a ten foot (10') straight edge-shall be considered failure of the mechanical compaction. The Contractor shall be required to repair such settlement without cost to the Owner.

#### **F Restoration of Surface Improvements**

Wherever any surface improvements such as pavement, curbing, pedestrian walks, fencing, or turf have been removed, damaged or otherwise disturbed by the Contractor's operations, they shall be repaired or replaced to the Engineer's satisfaction, as will restore the improvement in kind and structure to the preexisting condition. Each item of restoration work shall be done as soon as practicable after completion of installation and backfilling operations on each section of pipeline.

In the absence of specific payment provisions, as separate Contract Items, the restoration work shall be compensated for as part of the work required under those Contract Items which necessitated the destruction and replacement or repair, and there will be no separate payment. If separate pay items are provided for restoration work, only that portion of the repair or reconstruction which was necessitated by the Contract work will be measured for payment. Any improvements removed or damaged unnecessarily or undermined shall be replaced or repaired at the Contractor's expense.

#### **G Maintenance and Final Cleanup**

All subgrade surfaces shall be maintained acceptably until the start of surfacing construction or restoration work, and until the work has been finally accepted. Additional materials shall be provided and placed as needed to compensate for trench settlement and to serve as temporary construction pending completion of the final surface improvements.

Final disposal of debris, waste materials, and other remains or consequences of construction, shall be accomplished intermittently as new construction items are completed and shall not be left to await final completion of all work. Cleanup operations shall be considered an incidental part of the work covered under the Contract Items.

If disposal operations and other cleanup work are not conducted properly as the construction progresses, the Engineer may withhold partial payments until such work is satisfactorily performed or the Engineer may deduct the estimated cost of its performance from the partial estimate value.

#### **2600.4 METHOD OF MEASUREMENT**

All items will be measured separately according to design designation as indicated in the Pay Item name and as may be detailed and defined in the Plans, Specifications, or Special Provisions. Complete-in-Place items shall include all component parts thereof as described or required to complete the unit, but excluding any excesses covered by separate Pay Items.

##### **A Rock Excavation**

Rock Excavation shall be measured by volume in cubic yards. Depth shall be measured from the top of the rock to a point six inches below the outside barrel of the pipe and width shall be the inside diameter of the pipe plus twenty-four inches (24") (12" from each side). The minimum width of measurement shall be four feet (4').

##### **B Granular Materials**

Granular materials furnished and placed as special foundation, bedding, encasement, or backfill construction will be measured by weight or volume of material furnished by the Contractor from outside sources and placed within the limits defined. Unless otherwise specified, volume will be determined by vehicular measure (loose volume) at the point of delivery. Measurements will not include any materials required to be placed as a component part of other Contract Items as may be specified.

##### **C Geotextile Fabric**

Where geotextile fabric is used for improving pipe foundation, it shall be measured by the square yard of material installed.

##### **D Insulation**

Rigid board insulation shall be measured on a square yard basis installed to the specified thickness noted on the Plans, Specifications, and Special Provisions and shall include all materials, equipment, and labor required for placement.

## **2600.5 BASIS OF PAYMENT**

All costs of excavating to foundation grade, preparing the foundation, placing and compacting backfill materials, restoring surface improvements, and other work necessary for prosecution and completion of the work as specified, shall be included for payment as part of the pipe and pipe appurtenance items without any direct compensation being made.

In the absence of special payment provisions, all costs of restoring surface improvements as required, disposal of surplus or waste materials, maintenance and repair of completed work, and final cleanup operations shall be incidental to the Contract Items under which the costs are incurred.

Granular materials furnished for foundation, bedding, cover, or backfill placement as specified in connection with pipe or structure items will only be paid for as separate Contract Items to the extent that the Proposal contains specific Pay Items. Otherwise the furnishing and placing of granular materials as specified shall be incidental to the pipe or structure item without any direct compensation being made.

Materials utilized for filling annular spaces due to jacking/boring and drilling fluids for directional boring shall be incidental to the installation of the casing and pipe installed.

Contaminated Materials and Regulated Wastes not anticipated in the plans, specifications and special provisions and unexpectedly discovered during construction shall be compensated for as negotiated by supplemental agreement.

Contaminated Materials and Regulated Wastes specifically identified for payment in the plans, specifications, and special provisions, will be paid for under separate Contract Items provided in the Proposal.



## **SECTION 2611 – STANDARD SPECIFICATIONS FOR WATERMAIN AND SERVICE LINE INSTALLATION**

### **2611.1 DESCRIPTION**

This work shall consist of the construction of watermain and building service pipelines utilizing plant fabricated pipe and other appurtenant materials, installed for conveyance of potable water. The work includes the relocation or adjustment of existing facilities as may be specified in the Plans, Specifications and Special Provisions.

The use of the term "Plans, Specifications, and Special Provisions" within this specification shall be construed to mean those documents which compliment, modify, or clarify these specifications and are an enforceable component of the Contract Documents.

All references to MnDOT Specifications shall mean the latest published edition of the Minnesota Department of Transportation "Standard Specifications for Construction", and all supplements and amendments thereto, published prior to the date of advertisement for bids.

All reference to other Specifications of AASHTO, ASTM, ANSI, AWWA, etc. shall mean the latest published edition available on the date of advertisement for bids.

The following American Water Works Association (AWWA) Specifications and American Society for Testing and Materials (ASTM) Standards have been referenced in this Specification:

AWWA C104 Standard for Cement-Mortar Lining for Ductile-Iron Pipe and Fittings for Water

AWWA C105 Standard for Polyethylene Encasement for Ductile-Iron Pipe Systems

AWWA C110 Standard for Ductile-Iron and Gray-Iron Fittings, 3 In. Through 48 In. (75 mm Through 1200 mm)

AWWA C111 Standard for Rubber-Gasket Joints for Ductile-Iron Pressure Pipe and Fittings

AWWA C115 Standard for Flanged Ductile-Iron Pipe with Ductile-Iron or Gray-Iron Threaded Flanges

AWWA C116 Standard for Protective Fusion-Bonded Coatings for the Interior and Exterior Surfaces of Ductile-Iron and Gray-Iron Fittings

AWWA C150 Standard for Thickness Design of Ductile-Iron Pipe

AWWA C151 Standard for Ductile-Iron Pipe, Centrifugally Cast

AWWA C153 Standard for Ductile-Iron Compact Fittings, 3 In. through 64 In. (80 mm Through 1,600 mm)

AWWA C301 Standard for Prestressed Concrete Pressure Pipe, Steel-Cylinder Type

AWWA C304 Standard for Design of Prestressed Concrete Cylinder Pipe

AWWA C500 Standard for Metal-Seated Gate Valves for Water Supply Service

AWWA C502 Standard for Dry-Barrel Fire Hydrants

AWWA C504 Standard for Rubber-Seated Butterfly Valves

AWWA C509 Standard for Resilient-Seated Gate Valves for Water Supply

AWWA C515 Standard for Reduced-Wall, Resilient-Seated Gate Valves for Water Supply Service

AWWA C550 Standard for Protective Interior Coatings for Valves and Hydrants

AWWA C600 Standard for Installation of Ductile-Iron Water Mains and Their Appurtenances

AWWA C605 Standard for Underground Installation of Polyvinyl Chloride (PVC) and Molecularly Oriented Poly Vinyl Chloride (PVCO) Pressure Pipe and Fittings

AWWA C651 Standard for Disinfecting Water Mains

AWWA C800 Standard for Underground Service Line Valves and Fittings

AWWA C900 Standard for Polyvinyl Chloride (PVC) Pressure Pipe and Fabricated Fittings, 4 In. Through 60 In.  
AWWA C901 Standard for Polyethylene (PE) Pressure Pipe and Tubing, 3/4 In. Through 3 In., for Water Service  
AWWA C904 Standard for Crosslinked Polyethylene (PEX) Pressure Pipes, 1/2 In. (13 mm) Through 3 In. (76 mm) for Water Service  
AWWA C906 Standard for Polyethylene (PE) Pressure Pipe and Fittings, 4 In. Through 65 In., for Waterworks  
AWWA C907 Standard for Injection-Molded Polyvinyl Chloride (PVC) Pressure Fittings, 4 In. Through 12 In. (100mm Through 300 mm) for Water, Wastewater, and Reclaimed Water Service  
AWWA M55 Manual for P.E. Pipe Design and Installation

ASTM A48 Standard Specification for Gray Iron Castings  
ASTM A536 Standard Specification for Ductile Iron Castings  
ASTM B88 Standard Specification for Seamless Copper Water Tube  
ASTM C270 Standard Specification for Mortar for Unit Masonry  
ASTM C478 Standard Specification for Circular Precast Reinforced Concrete Manhole Sections  
ASTM D543 Standard Practices for Evaluating the Resistance of Plastics to Chemical Reagents  
ASTM D1248 Standard Specification for Polyethylene Plastics Extrusion Materials for Wire and Cable  
ASTM D1784 Standard Specification for Rigid Poly (Vinyl Chloride) (PVC) Compounds and Chlorinated Poly (Vinyl Chloride) (CPVC) Compounds  
ASTM D1785 Standard Specification for Poly (Vinyl Chloride) (PVC) Plastic Pipe, Schedules 40, 80, and 120  
ASTM D2241 Standard Specification for Poly (Vinyl Chloride) (PVC) Pressure Rated Pipe (SDR Series)  
ASTM D2466 Standard Specification for Poly (Vinyl Chloride) (PVC) Plastic Pipe Fittings, Schedule 40  
ASTM D2467 Standard Specification for Poly (Vinyl Chloride) (PVC) Plastic Pipe Fittings, Schedule 80  
ASTM D3035 Standard Specification for Polyethylene (PE) Plastic Pipe (DR PR) Based on Controlled Outside Diameter  
ASTM D3261 Standard Specification for Butt Heat Fusion Polyethylene (PE) Plastic Fittings for Polyethylene (PE) Plastic Pipe and Tubing  
ASTM D3350 Standard Specification for Polyethylene Plastics Pipe and Fittings Materials  
ASTM F593 Standard Specification for Stainless Steel Bolts, Hex Cap Screws, and Studs  
ASTM F594 Standard Specification for Stainless Steel Nuts  
ASTM F714 Standard Specification for Polyethylene (PE) Plastic Pipe (DR PR) Based on Outside Diameter  
ASTM F876 Standard Specification for Crosslinked Polyethylene (PEX) Tubing  
ASTM F877 Standard Specification for Crosslinked Polyethylene (PEX) Hot and Cold-Water Distribution Systems

Service installations shall include either Branch Service Lines or Tapped Service Lines in accordance with the standards set forth herein.

Tapped Service installations shall include all water service lines less than three inches (3") nominal inside diameter pipe. The component parts of a tap service installation shall include a corporation stop coupling complete with watermain tap and saddle where required; a curb stop coupling complete with service box; and service piping extending from the corporation stop to the curb stop coupling and beyond to the property line or to the limits as established by the Engineer.

Branch Service installations shall include all water service lines of three inches (3") nominal inside diameter pipe and larger. The component parts of a branch service installation shall include a tapping sleeve and valve or a tee connection and valve complete with valve box, and piping extending from the watermain connection, to the property line or to the limits as specified by the Engineer.

All references to "structure" shall include any man-made object that is not otherwise exempted by special terminology or definition.

## **2611.2 MATERIALS**

All materials required for this work shall be new material conforming to requirements of the reference specifications for the class, kind, type, size, grade, and other details indicated in the Contract. Unless otherwise indicated, all required materials shall be furnished by the Contractor. If any options are provided for, as to type, grade, or design of the material, the choice shall be limited as may be stipulated in the Plans, Specifications, or Special Provisions.

All manufactured products shall conform in detail to such standard design drawings as may be referenced or furnished in the Plans. Otherwise, the Owner may require advance approval of material suppliers, product design, or other unspecified details as it deems desirable for maintaining adopted standards.

At the request of the Engineer, the Contractor shall submit, in writing, a list of materials and suppliers for approval.

A Certificate of Compliance shall be furnished stating that the materials furnished have been tested and are in compliance with the specification requirements.

### **A Water Pipe Materials**

All pipe furnished for watermain and branch line installations shall be of the type, kind, size, and class indicated for each particular line segment as shown in the Plan and designated in the Contract Items. Wherever connection of dissimilar materials or designs is required, the method of joining and any special fittings employed shall be subject to approval of the Engineer.

#### **A1 Ductile Iron Pipe and Ductile Iron and Gray Iron Fittings**

The pipe furnished shall be Ductile Iron pipe and pipe fittings furnished shall be of the Ductile Iron or Gray Iron type as specified for each particular use of installation. When Gray Iron is specified, either type may be furnished. Gray Iron may not be substituted for Ductile Iron unless specifically authorized in the Special Provisions.

Ductile iron pipe shall conform to the requirements of AWWA C115 or C151 for potable water, and thickness design shall conform to AWWA C150. In addition, the pipe shall comply with the following supplementary provisions:

- (1) Fittings shall conform to the requirements of AWWA C110 (Gray Iron and Ductile Iron Fittings) or AWWA C153 (Ductile Iron Compact Fittings) for the joint type specified.
- (2) Unless otherwise specified all pipe and fittings shall be furnished with cement mortar lining meeting the requirements of AWWA C104 for standard thickness lining. All exterior surfaces of the pipe and fittings shall have an asphaltic coating at least one mil thick. Spotty or thin seal coating, or poor coating adhesion, shall be cause for rejection.

Fittings specified to be furnished with fusion bonded epoxy external coating and/or interior lining shall conform to the requirements of AWWA C550 and C116/A21.16, with 6-8 mil nominal thickness.

- (3) Rubber gasket joints for Ductile Iron Pressure Pipe and fittings shall conform to AWWA C111.
- (4) The nuts and bolts shall be constructed of corrosion resistant, high-strength, low-alloy steel with a ceramic filled, baked on fluorocarbon resin. The nuts and bolts shall be in compliance with ANSI/AWWA C111/A21.11.
- (5) Conductivity shall be maintained through pipe and fittings with an external copper jumper wire or specialty gaskets which are capable of meeting conductive requirements. Wedge type connectors will not be allowed.

## **A2 Polyvinyl Chloride (PVC) Pressure Pipe and Fittings**

Polyvinyl chloride (PVC) pressure pipe shall be manufactured with compounds conforming to ASTM D1784 and shall conform to the requirements of AWWA C900 and Fusible C900, for the size, grade, and pressure class indicated on the Plans, Specifications, and Special Provisions. Fittings shall be the same pressure class as the pipe and shall conform to AWWA C907. PVC pressure pipe and fittings shall have a pressure rating of one hundred sixty (160) psi or greater, unless otherwise provided in the special provisions. The grade used shall be resistant to aggressive soils or corrosive substances in accordance with the requirements of ASTM D543. Unless otherwise specified, the dimensions and tolerances of the pipe barrel should conform to ductile iron or cast-iron pipe equivalent outside diameters.

## **A3 Polyethylene (PE) Pressure Pipe and Fittings**

Polyethylene pressure pipe and fittings shall be manufactured with compounds conforming to ASTM D3350 and shall conform to ASTM D3035 and AWWA C-901 (for 0.75" to 3" diameters) and ASTM F714 and AWWA C906 (for 4" to 65" diameters) for the size, grade and pressure class indicated on the plans, specifications and special provisions. Polyethylene pipe and fittings shall be PE 3608 or PE 4710 for potable water transmission and pressure rating of one hundred sixty (160) psi or greater, unless otherwise provided in the special provisions. The pipe and fittings shall be manufactured from the same resin type, grade, and cell classification. Unless otherwise specified, the dimensions and tolerances of the pipe barrel shall conform to

Ductile Iron Pipe equivalent outside diameters (DIPS) for pipe diameters greater than three inches (3"). The method of joining material shall be by the Thermal Butt Heat Fusion Method in accordance with ASTM D3261.

The minimum "quick-burst" strength of the fittings shall not be less than that of the pipe with which the fitting is to be used.

## **B Fire Hydrants**

Fire hydrants shall be of the type, size, and construction specified in the Plans and shall conform to the applicable requirements of AWWA C502.

Unless otherwise specified in the Plans, Specifications, and Special Provisions, hydrants shall be furnished in conformance with the following supplementary requirements:

- (1) Hydrants shall have a five inch (5") (nominal diameter) main valve opening of the type that opens against water pressure.
- (2) Hydrant barrels shall be two (2) piece, non-jacket type, with flanged joint above finished grade line and with mechanical joint connection at the hub end for joining a six inch (6") ductile iron branch pipe.
- (3) Hydrant operating rod shall be equipped with a breakable joint coinciding with the flange joint above the grade line.
- (4) Hydrant bury length shall be measured from the bottom of the branch pipe connection to the finished ground line at the hydrant.
- (5) Hydrants shall have two (2) outlet nozzles for two and one-half inch (2-1/2") (I.D.) hose connection and one outlet nozzle for four-inch (4") (I.D.) steamer connection. All outlet nozzle threads shall be National Standard Fire-Hose Coupling Screw Threads (NFPA 1963).
- (6) Hydrant operating mechanisms shall be provided with "O" ring seals preventing entrance of moisture and shall be lubricated through an opening in the operating nut or bonnet.
- (7) Hydrants shall be provided with outlets for drainage in the base or barrel, or between the base and barrel, unless the Special Provisions require that drain outlets be omitted or plugged.
- (8) The hydrant operating nut shall be rotated counterclockwise to open.
- (9) Detailed drawings, catalog information, and maintenance data shall be furnished as requested by the Engineer.

- (10) Hydrant body bolts shall be corrosion resistant, stainless steel conforming to the requirements of ASTM F593 and F594, alloy group 1, 2, 3, suitable for exterior use above and below ground. Bolts shall conform to manufacturer recommendation for tensile strength and torque.

## **C Valves and Valve Housing**

### **C1 Valve Housings**

Valve housings shall be of ductile or cast iron, High Density Polyethylene or masonry construction as specified in the Plans, Specifications, and Special Provisions for the particular valve size or installation. Masonry manhole or vault type units shall be constructed in accordance with the provisions of MnDOT Specification 2506. Precast Concrete Manholes shall conform to ASTM C478 suitable for HS 20 traffic loading for all units located in driving areas. Ductile or cast-iron valve boxes and all castings for manhole or vault type units shall conform to the requirements of MnDOT Specification 3321.

### **C2 Gate Valves**

Gate Valves shall conform to all applicable requirements of AWWA C500 or AWWA C509 or AWWA C515, together with such supplementary requirements as may be covered in the Plans, Specifications, and Special Provisions. Unless otherwise specified gate valves shall comply with the following supplementary requirements:

- (1) Gate valves meeting the requirements of AWWA C500 shall be two-faced, double disc type, with parallel seats. Gate valves meeting the requirements of AWWA C509 and C515 shall be single disc type with resilient seat bonded or mechanically attached to either the gate or valve body, and the wedge shall be ductile iron fully encapsulated with EPDM rubber, shall be symmetrical and seal equally well with flow in either direction without misalignment. All valves shall be provided with a two-inch square operating nut opening counterclockwise and mechanical joint ends.
- (2) All gate valves shall be non-rising stem (NRS) type furnished with O-Ring stem seals.
- (3) All gate valves sixteen inches (16") or larger in size shall be arranged for operation in the horizontal position and shall be equipped with bypass valves.
- (4) All gears on gate valves shall be cut tooth steel gears, housed in heavy ductile or cast iron extended type grease cases of approved design.
- (5) All gate valves shall have an open indicating arrow, the manufacturer's name, pressure rating and year of manufacture cast on the valve bodies.
- (6) All internal and external surfaces of the valve body and bonnet shall have an epoxy coating, complying with ANSI/AWWA C550.
- (7) All gate valves shall have stainless steel body bolts unless otherwise specified.

### **C3 Butterfly Valves**

Butterfly valves shall be manufactured in conformance with all applicable requirements of AWWA C504 for 150 p.s.i. working pressure minimum, together with such supplementary requirements as may be covered in the Plans, Specifications, and Special Provisions. Unless otherwise specified, the butterfly valves furnished shall comply with the following supplementary requirements.

- (1) The butterfly valves shall be short body of ductile or cast iron with mechanical joint ends.
- (2) The butterfly valves shall be rubber seated with ductile or cast disc, non-rising stem type furnished with O-ring stem seals.
- (3) The butterfly valves shall be equipped with a two-inch square operating nut opening counterclockwise.
- (4) The butterfly valves shall be designed for direct burial installation.
- (5) All butterfly valves shall have an open indicating arrow, the manufacturer's name, pressure rating and year of manufacture on the valve bodies.
- (6) All internal and external surfaces of the valve body and bonnet shall have an epoxy coating, complying with ANSI/AWWA C550.
- (7) All butterfly valves shall have stainless steel body bolts unless otherwise specified.

### **D Water Service Pipe and Fittings**

Water service pipe of 3 inches or larger inside diameter shall conform to the requirements as set forth under the provisions of 2611.2.

Water service pipe of less than three inch (3") inside diameter shall conform to the requirements of ASTM B88 for Seamless Copper Water Tube, Type K, Soft Annealed temper; Polyethylene Pipe as per AWWA C901 and ASTM D3350, or Polyvinyl Chloride Pipe and fittings as per a ASTM D1785, D2241, D2466, D2467 and D2740, or Cross-linked Polyethylene (PEX) pipe as per ASTM F876, ASTM F877, and AWWA C904, NSF/ANSI Standard 61 for potable water distribution, as specified on the Proposal or in the Special Provisions. Water service piping supplied shall include markings indicating the type, pressure class, testing certification, and use for potable water systems.

Corporation stops, saddles, curb stops, and curb stop service boxes shall conform to the requirements of AWWA C800 and as detailed in the Plans, Specifications, and Special Provisions or approved designations.

Saddles for Polyethylene Pipe shall conform to the requirements of AWWA C800 and shall be thermal fusion polyethylene type; ductile iron with dual stainless steel straps, spring washers, bolts and washers; or stainless steel sleeve type, with stainless steel bolts, nuts, and spring washers. Stainless steel bolts, nuts, and washers. Spring washers shall be manufactured from type 304 stainless steel, special "spring grade". Saddles shall include threaded outlet tapping sleeves and Nitrile Butadiene Rubber (NBR) gaskets.

All fittings for copper tubing shall be cast brass, having uniformity in wall thickness and strength, and shall be free of defects affecting serviceability. All copper pipe fittings shall be flared or compression type. All threads for underground service line fittings shall conform to the requirements of AWWA C800. Each fitting shall be permanently and plainly marked with the name or trademark of the manufacturer. Fittings for thermoplastic pipe types shall be of the same material and pressure class as the piping.

Curb stop service boxes shall be gray iron conforming to the requirements of ASTM A 48 for Class 20 or higher tensile strength and shall have at least twelve inches (12") of vertical adjustment for the cover depth specified in the Plans, Specifications, and Special Provisions.

#### **E Polyethylene Encasement Material**

Polyethylene encasement material shall conform to the requirements of AWWA C105 for tube type installation and 8 mil nominal film thickness.

#### **F Mechanical Joint Restraints**

Mechanical joint restraints shall be ductile iron conforming to the requirements of ASTM A536 and AWWA C600. Joint restraints shall be Lug or Grip Ring type, and be designed to withstand the design pressures indicated in the Plans, Specifications, and Special Provisions.

Mechanical joint restraints shall be fusion bonded epoxy coated meeting the requirements of AWWA C116.

All nuts, bolts, and tie rod type restraints shall be stainless steel, corrosion-resistant coating, or coated with an owner approved rustproofing material.

#### **G Mortar**

Mortar for use in masonry construction shall meet the requirements of MNDOT 2506.2B and ASTM C270.

#### **H Concrete**

Concrete used for cast-in-place masonry construction shall be produced and furnished in accordance with the provisions of MnDOT Specification 2461 for the mix design indicated in the Plans, Specifications, or Special Provisions. The requirements for Grade B concrete shall be met where a higher grade is not specified. Type 3, air-entrained, concrete shall be furnished and used in all structures having weather exposure.



## **I Tracer Wire for Non-Conductive Pipe**

Tracer wire for use with all thermoplastic pipe types shall be Underwriters Laboratories (UL) listed for use in direct burial applications, color coated per APWA uniform color code for the specific utility being marked. Tracer wire shall be a minimum 12 AWG copper clad steel rated to 30 volts, insulation shall be High Molecular Weight Polyethylene (HMWPE) meeting ASTM D1248, with designation identified on the outside of the wire casing.

Tracer wire shall meet the following additional criteria for the construction method specified:

Open Trench - Trace wire shall be High Strength with minimum 450 lb. break load, with minimum 30 mil HDPE insulation thickness.

Directional Drilling/Boring - Trace wire shall be Extra High Strength with minimum 1,150 lb. break load, with minimum 30 mil HDPE insulation thickness.

Pipe Bursting/Slip Lining - Trace wire shall be 7 x 7 Stranded Copper Clad Steel, Extreme Strength with 4,700 lb. break load, with minimum 50 mil HDPE insulation thickness.

Connectors for tracer wire shall meet the following:

All mainline trace wires must be interconnected at tees and crosses, joined using a single 3-way or 4-way lockable connector for tees and crosses, respectively.

Lockable connectors shall be for direct bury application and shall be dielectric silicon filled to seal out moisture and corrosion.

## **2611.3 CONSTRUCTION REQUIREMENTS**

### **A Installation of Pipe and Fittings**

Installation of ductile iron watermains and their appurtenances shall conform to the requirements of AWWA C600, the Plans, Specifications and Special Provisions.

Installation of Polyvinyl Chloride (PVC) pipe and their appurtenances shall conform to the requirements of AWWA C605, and the bedding and backfill conditions specified by the Manufacturer, Plans, Specifications, and Special Provisions.

Installation of Polyethylene Pipe and their appurtenances shall conform to the requirements of AWWA M55 and to the bedding and backfill conditions specified by the Manufacturer, Plans, Specifications, and Special Provisions.

No existing valves or hydrants shall be operated by individuals other than personnel from the City Public Works Department. Only under emergency conditions or after specific authorization is given by the City Public Works Department shall the Contractor operate valves or hydrants.

Installation of pipe and fittings shall also conform to the following general guidelines:

### **A1 Inspection and Handling**

Proper and adequate implements, tools, and facilities satisfactory to the Engineer shall be provided and used by the Contractor for the safe and convenient prosecution of the work.

During the process of unloading delivered materials, all pipe and accessories shall be inspected by the Contractor for damage. The Contractor shall notify the Engineer of all material found to have cracks, flaws or other defects. The Engineer shall inspect the damaged material and have the right to reject any materials found to be unsatisfactory. The Contractor shall promptly remove all rejected material from the site.

All materials shall be handled carefully, as will prevent damage to protective coatings, linings, and joint fittings; preclude contamination of interior areas; and avoid jolting contact, dropping, or dumping.

During pipe laying operations, each pipe section shall be inspected by the Contractor. The Contractor shall inform the Engineer of any defects discovered and the Engineer will prescribe the required corrective actions or order rejection.

Immediately before placement, the joint surfaces of each pipe section and fitting shall be inspected for the presence of foreign matter, coating blisters, rough edges or projections, and any imperfections so detected shall be corrected by cleaning, trimming, or repair.

### **A2 Pipe Laying Operations**

Trench excavation and bedding preparations shall proceed ahead of pipe placement as will permit proper placement and joining of the pipe and fittings at the prescribed grade and alignment without unnecessary hindrance. All foreign matter or dirt shall be removed from the inside of the pipe and fittings before they are lowered into position in the trench, and they shall be kept clean. The watermain materials shall be carefully lowered into laying position by the use of suitable restraining devices. Under no circumstances shall the pipe be dropped or dumped into the trench.

As each length of bell and spigot pipe is placed in laying position, the spigot end shall be centered in the bell and the pipe forced home and brought to correct line and grade. The pipe shall be secured in place with approved encasement and backfill materials.

When pipe laying is not in progress, all open ends of the pipe line shall be closed by watertight plugs or other means approved by the Engineer. If water is present in the trench, the plugs shall remain in-place until the trench is pumped completely dry.

When connecting to existing stubs, the Contractor shall prevent dirt or debris from entering the existing pipe.

### **A3 Aligning and Fitting of Pipe**

The cutting of pipe for inserting valves, fittings, or closure pieces shall be done in a neat and workmanlike manner without damage to the pipe and so as to leave a smooth square-cut end. Pipe shall be cut with approved mechanical tools. Flame cutting will not be allowed under any conditions. All rough edges shall be removed from the cut ends of pipe and, where rubber gasket joints are used, the outer edge shall be rounded or beveled by grinding or filing to produce a smooth fit.

When necessary to deflect pipe from a straight line either in the vertical or horizontal plane to avoid obstructions, plumb stems, or produce a long radius curve when permitted, the amount of deflection allowed at each joint shall not exceed the limits to maintain a satisfactory joint seal in conformance with AWWA C600 for ductile iron pipe mechanical and push-on joints, AWWA C605 for PVC pipe and AWWA M55 for PE pipe. The maximum angular deflection at any joint for other pipe materials and joints shall not exceed the manufacturer's recommendations. If the specified alignment requires angular deflections greater than recommended or allowed, the Contractor shall provide appropriate bends or shorter pipes such that the maximum angular deflection is not exceeded.

### **A4 Blocking and Anchoring of Pipe**

All plugs, caps, tees, bends, and other thrust points shall be provided with reaction backing, or movement shall be prevented by attachment of suitable restraining devices or tie rods, in accordance with the requirements of the Plans, Specifications, and Special Provisions.

In the absence of other specified requirements for reaction backing or restraining devices, the following provisions shall apply:

- (1) All horizontal bends exceeding twenty (20) degrees deflection, and all caps, plugs, and branch tees shall be provided with concrete buttress blocking.
- (2) All vertical bends exceeding twenty (20) degrees deflection shall be provided with concrete buttress blocking at the low points and with metal tie rod or strapping restraints at the high points.
- (3) Offset bends made with standard offset fittings need not be strapped or buttressed.
- (4) Hardwood blocking shall not be used.

Concrete buttresses shall be poured against firm, undisturbed ground and shall be formed in such a way that the joints will be kept free of concrete and remain accessible for repairs. The concrete mix used in buttress construction shall meet the requirements for Grade B concrete in conformance with MnDOT Specification Section 2461. Buttress dimensions shall be a minimum of twelve inches (12") in thickness, and the minimum area, in square feet shall be as follows.

PIPE SIZE	TEE OR PLUG	1/4 BEND	1/8 BEND	1/32 BEND 1/16 BEND
6"	2.9	3.1	1.6	0.8
8"	3.7	5.3	2.9	1.4
10"	5.7	8.1	4.4	2.2
12"	8.1	13.4	6.6	3.2
16"	15.1	21.4	11.6	5.9
20"	23.2	30.2	18.1	9.3
24"	33.6	48.5	26.1	13.3

Contractors are instructed to size concrete buttress blocking on fittings and dead ends where the blocking must withstand the pressure of larger main line fittings equipped with reducers, for the larger sized main line thrust and not for smaller fitting size only. This is of particular importance on tees and crosses where the main size is reduced on the run from large to small size by use of reducers.

All metal parts of tie rod or strap type restraints shall be galvanized or coated with other approved asphaltic type rustproofing.

All necessary fittings, bands, tie rods, nuts, and washers, and all labor and excavation required for installation of reaction restraints shall be incidental to the installation of the pipe, unless a specific payment item is provided in the bid proposal.

#### **A5 Polyethylene Encasement of Pipeline**

Wherever so required by the Plans, Specifications, or Special Provisions the pipeline, including valves, fittings, and appurtenances, shall be fully encased in polyethylene film meeting the requirements of these Specifications. The film shall be furnished in tube form for installation on pipe and all pipe-shaped appurtenances such as bends, reducers, off-sets, etc. Sheet film shall be provided and used for encasing all odd-shaped appurtenances such as valves, tees, crosses, etc.

The polyethylene tubing shall be installed on the pipe prior to being lowered into the trench. Tubing length shall be sufficient to provide a minimum overlap at all joints of one foot or more. Overlap may be accomplished with a separate sleeve tube placed over one end of the pipe prior to connecting another section of pipe, or by bunching extra overlap material at the pipe ends in accordion fashion. After completing the pipe jointing and positioning the overlap material, the overlap shall be secured in place with plastic adhesive tape wrapped circumferentially around the pipe not less than three (3) turns.

After encasement, the circumferential slack in the tubing film shall be folded over at the top of the pipe to provide a snug fit along the barrel of the pipe. The fold shall be held in place with plastic adhesive tape applied at intervals of approximately three feet (3') along the pipe length. Also, any rips, punctures, or other damage to the tubing shall be repaired as they are detected. These repairs shall be made with adhesive tape and overlapping patches cut from sheet or tubing material.

At odd-shaped appurtenances such as gate valves, the tubing shall overlap the joint and be secured with tape, after which the appurtenant piece shall be wrapped with a flat film sheet or split length of tubing by passing the sheet under the appurtenance and bringing it up around the body. Seams shall be made by bringing the edges together, folding over twice, and taping down. Wherever encasement is terminated, it shall extend for at least two feet (2') beyond the joint area.

Openings in the tubing for branches, service taps, air valves and similar appurtenances shall be made by cutting an X-shaped slit and temporarily folding back the film. After installing the appurtenance, the cut tabs shall be secured with tape and the encasement shall be completed as necessary for an odd-shaped appurtenance.

Unless otherwise specified in the Plans, Specifications, and Special Provisions, hydrants encased in polyethylene tubing shall have plugged drain outlets.

## **B Connection and Assembly of Joints**

Where rubber gasket joints are specified, care shall be taken during the laying and setting of piping materials to ensure that the units being joined have the same nominal dimension of the spigot outside diameter and the socket inside diameter. A special adaptor shall be provided to make the connection when variations in nominal dimension might cause unsatisfactory joint sealing.

Immediately before making the connection, the inside of the bell or socket and the outer surface of the spigot ends shall be thoroughly cleaned to remove oil, grit, excess coating, and other foreign matter. Insertion of spigot ends into the socket or bell ends shall be accomplished in a manner that will assure proper centering and insertion to full depth. The joint seal and securing requirements shall be as prescribed below for the applicable pipe and joint type.

### **B1 Ductile Iron Pressure Pipe and Fitting Joints**

#### *B1a Push-On Joints*

The circular rubber gasket shall be kept in a warm, flexible condition at all times, and for purposes of placement shall be flexed inward and inserted in the gasket recess of the bell socket. A thin film of approved gasket lubricant shall be applied to either the inside surface of the gasket or the outside surface of the spigot end, or to both. Care shall be taken while inserting the spigot end to prevent introduction of contaminants. The joint shall be completed by forcing the spigot end to the bottom of the socket using suitable pry-bar or jack type equipment. Spigot ends which do not have depth marks shall be marked before assembly to ensure full insertion. The use of the bucket on the excavation equipment to force the pipe into the socket shall not be permitted.

### *B1b Mechanical Joints*

The last eight inches (8") of the outside spigot surface and the inside bell surface of each pipe and appurtenance joint shall be painted with a thin film of approved gasket lubricant after being thoroughly cleaned. The gland shall then be slipped on the spigot end with the lip extension toward the socket or bell end. The rubber gasket shall be kept in a warm, flexible condition at all times, and for purposes of placement shall be painted with a thin film of approved gasket lubricant and be placed on the spigot end with the thick edge toward the gland

After the spigot end is inserted into the socket to full depth and centered, the gasket shall be pressed into place within the bell evenly around the entire joint. After the gland is positioned behind the gasket, all bolts shall be installed and the nuts tightened alternately to the specified torque, such as to produce equal pressure on all parts of the gland.

Unless otherwise specified, the bolts shall be tightened by means of a suitable torque-limiting wrench to within a foot-pound range of: 45 to 60 for 5/8 inch bolts; 75 to 90 for 3/4 inch bolts; 85 to 100 for 1 inch bolts; and 105 to 120 for 1-1/4 inch bolts. After tightening, all exposed parts of the bolts and nuts shall be completely coated with an approved asphaltic type rust preventive material.

### *B1c Flanged Joints*

Flanged joints shall be installed only in above grade or exposed locations and shall conform to the requirements of AWWA C115, the Plans, Specifications and Special Provisions. Flanged joints shall have full face gaskets.

## **B2 Polyvinyl Chloride Pipe Joints**

### *B2a Push-On Joints*

The circular rubber gasket shall be bonded to the inner wall of the gasket recess of the bell socket. Installation of pipe spigot into the bell socket shall conform to the requirements for Ductile Iron Push-On Joints as set forth under the provisions of 2611.3B1a.

## **B3 Polyethylene Pipe Joints**

Polyethylene pipe joints shall conform to the requirements of AWWA C906, and shall be made by the Thermal Butt Heat Fusion Method, Mechanical Flange Adaptor Method, Mechanical Joint Adaptor Method and Mechanical Transition Fittings. Mechanical joints shall include stainless steel pipe stiffeners. Compression fittings are not allowed for pipe diameters greater than two inches (2") in diameter.

## **B4 Tracer Wire for Non-conductive Pipe**

Tracer wire shall be installed along the length of all non-conductive mainline pipes, laterals, and services with vertical riser to the surface, at gate valve boxes, hydrants, curb boxes, and/or utility location boxes as required by the Special Provisions. Tracer wire shall be taped, clamped or affixed to the pipe in another manner as approved by the Engineer.

Splicing tracer wire shall be in a manner to prevent any uninsulated wire exposure.

A twelve-inch (12") tracer wire loop shall be provided on each side of a spliced connection.

Tracer wire lengths greater than 500 linear feet without service laterals or hydrants are to include an approved grade level/in-ground access box, located at the edge of the road right-of-way and outside of the roadway.

Tracer wire shall be grounded at all terminal ends (stubs, plugs).

## **C Water Service Installations**

Water service facilities consisting of Tap Service Lines and Branch Service Lines, complete with all required appurtenances, shall be installed as required by in the Plans, Specifications, and Special Provisions, in accordance with all pertinent requirements for main line installations together with the provisions hereof.

It shall be the responsibility of the Contractor to keep an accurate record of the location, depth and size of each service connection and other pertinent data such as the location of curb stops and pipe endings. Tap locations shall be recorded in reference to survey line stationing. Curb stops shall be tied to definable land marks such as building corners, lot corner markers, hydrants, gate valves, etc. Pipe terminals at the property line shall be marked to the ground surface with a suitable wood timber four by four inch (4"x4"), eight feet (8') long set vertically into the ground with the top two feet (2') painted blue. Approved record keeping forms will be furnished by the Engineer and the completed records shall be submitted by the Contractor upon completion of the work.

Water service lines shall be subject to the same requirements as prescribed for the main pipeline installation.

Water service lines shall be installed to provide a minimum of six inches (6") of clearance shall be maintained in crossing over or under other structures. Where the service pipe may be exposed to freezing due to insufficient cover or exposure from other underground structures, the water pipe shall be insulated as directed by the Engineer.

### **C1 Tee Branch Service Lines**

Tee branch service piping shall be of the type, size, and wall thickness specified. The pipe and appurtenances shall have rubber gasketed push-on or mechanical joints. Tee branch service lines shall be provided as required by the Plans.

Installation of tee branch service facilities shall be in accordance with all applicable requirements of these specifications as pertain to the mainline installations.

### **C2 Tapped Service Lines**

Service piping shall be of the size and type specified. Unless otherwise specified, minimum pipe size for tap service installations shall be one inch (1") nominal inside diameter. Larger size pipe may be specified for commercial and industrial uses or for some domestic service as specifically identified.

Installation of service facilities shall be in accordance with all applicable requirements of these specifications as pertain to the mainline installations, subject to the exceptions and supplementary provisions set forth hereinafter.

Installation of tapped service lines shall be performed while the mainline watermain is at system operating pressure. Dry tapping watermain pipe will not be allowed.

Unless otherwise indicated, service piping may be laid directly on any solid foundation soil that is free of stones and hard lumps. However, when specified or ordered, aggregate materials shall be furnished and placed as necessary to secure proper foundation drainage, pipe covering, or backfill support.

Tapped service piping of three quarters inch (3/4") to and including one and one quarter inches (1-1/4") in diameter shall be installed in one piece without intermediate joint couplings between the corporation stop and the curb stop. Service pipe of one and one half inches (1-1/2") in diameter and larger shall be furnished in standard roll lengths to eliminate any intermediate joints. When full roll lengths are less than the service length the rolls may be joined with approved couplings.

Unless otherwise specified, connection of tapped service lines to the watermain shall be made at an angle of not more than twenty-two (22) degrees from the horizontal. A double wrap of Teflon tape shall be placed on the corporation stop threads prior to installation in the main.

Unless otherwise indicated, tap service lines shall be installed on a straight line at right angles to the watermain or property line as directed by the Engineer. In the absence of specific requirements, the service line shall be terminated at the property line, where it shall be connected to an existing line or, in the case of undeveloped property, it shall be capped, plugged, or peened as approved by the Engineer.

The flaring of new copper tubing ends shall be accomplished only with the use of the proper size and type of tools as designed for the purpose. Tubing shall be cut squarely and all edge roughness shall be removed prior to flaring. All couplings shall be tightened securely, so the flared end fits snugly against the bevel of the fitting without leakage. The flared joint couplings shall be made up without the use of jointing compounds.

The service pipe and curb stop coupling depth shall be such as to maintain not less than the specified minimum cover. The service box shall be connected to or centered over the curb stop and be firmly supported on concrete blocking as required by the Plans, Specifications, and Special Provisions. Clearance shall be provided so the service box does not rest on the water pipe. Service boxes shall be installed plumb.

The service boxes shall be brought to proper surface grade when the final ground surface has been established.



## **D Setting Valves, Hydrants, Fittings and Specials**

Valves, hydrants, fittings, and specials shall be provided and installed as required by the Plans, Specifications, and Special Provisions with the exact locations and setting as directed by the Engineer, and with each installation accomplished in accordance with the requirements for installation of mainline pipe to the extent applicable. Support blocking, reaction backing, and anchorage devices shall be provided as required by the Plans, Specifications, and Special Provisions or as otherwise ordered by the Engineer.

Hydrants shall be installed plumb, with the height and orientation of nozzles as shown in the Plans or as directed by the Engineer. Unless otherwise specified, the hydrants shall be connected to the mainline pipe with six-inch (6") diameter pipe, controlled by an independent valve.

When a hydrant with an open drain outlet is set in clay or other impervious soil, a drainage pit of at least one cubic yard shall be excavated below and around the hydrant base and the pit shall be filled with Foundation Material to a level six inches (6") above the drain outlet. MnDOT 3733 geotextile Type 5, or other material approved by the Engineer, shall be carefully placed over the rock to prevent backfill material from entering voids in the rock drain. Hydrants located where the groundwater table is above the drain outlet shall have the outlet drain hole plugged or the drain tube cut off to prevent draining, and shall be equipped with a tag stating, "Pump After Use".

Valve boxes shall be centered over the valve wrench nut and be installed plumb, with the box cover flush with the surface of the finished pavement or at such other level as may be directed.

Valve box adaptors for use to stabilize the valve box in a centered position over the valve wrench nut shall include a rubber gasket between the adaptor plate and valve body. The adaptor shall be epoxy coated conforming to the requirements for fittings in section 2611.2A1, or as otherwise allowed by the plans, specifications and special provisions. Gate valve box adaptors shall be incidental to the valve box unless otherwise provided in the bid proposal.

Masonry valve pit structures, for valves with exposed gearing or operating mechanisms, shall be constructed in accordance with the details shown in the Plans and with the applicable provisions of these Specifications.

Drainage blow-offs, air vents, and other special appurtenances shall be provided and installed as required by the Plans, Specifications, and Special Provisions.

All dead ends shall be closed with approved plugs or caps and shall be equipped with suitable blow-off facilities.

## **E Disinfection of Watermains**

Before being placed in service, the completed water main shall be disinfected. Disinfection materials and procedures, and the collection and testing of water samples, shall be in accordance with the provisions of AWWA C651. After the final flushing of watermain, the water shall be tested for bacteriologic quality and found to meet the standards prescribed by the Minnesota Department of Health.

Where an existing watermain is cut for the installation of any fitting, the pipe and fittings proposed to be installed shall be disinfected prior to installation as follows:

- (1) The interior of the pipe and fittings shall be cleaned of all dirt and foreign material.
- (2) The interior of the pipe and fittings shall be thoroughly swabbed or sprayed with a one percent (1%) minimum hypochlorite solution.

Unless otherwise indicated in the Plans, Specifications, and Special Provisions, the Contractor shall furnish all materials and perform the disinfecting, flushing, and testing as necessary for meeting the water quality requirements.

The flushing operations and the form of chlorine and method of application to be used shall be subject to approval by the Engineer.

#### **F Electrical Conductivity Test**

The Contractor shall perform a conductivity test within one week after completion of pressure testing of the main on all watermains to ensure continuous conductivity for locating watermain. Sufficient conductivity shall be provided to allow for the location of watermain, services, hydrant leads, and laterals for mainline segments at least one thousand two hundred (1,200) linear feet in length

#### **G Hydrostatic Testing of Watermains**

After the pipe has been laid, including fittings and valves and blocking, all newly-laid pipe or any section between valves thereof, unless directed otherwise by the Engineer, shall be subject to hydrostatic pressure of one hundred fifty (150) pounds per square inch. The duration of each such test shall be at least two (2) hours.

Each section of pipe to be tested shall be filled with water and all air expelled at the highest point. The required taps to expel air or to fill the watermain shall be supplied and installed by the Contractor, shall be three quarters inch (3/4") and shall include an approved service saddle when required.

The test apparatus shall be applied at the lowest elevation on the section to be tested. The apparatus shall be connected to the main at a service tap or special tap location.

The pressure gauge shall be a standard pressure gauge. The dial shall register from 0 - 200 psi and have a dial size of four and one half inches (4-1/2") with one (1) psi increments.

The hydrostatic test pressure requirement for an acceptable test shall be a maximum pressure drop of two (2) psi during the last hour of the two (2) hour pressure test. The test pressure shall not drop more than five (5) psi for the duration of the test.

If this test requirement cannot be met, the Contractor shall investigate the cause, make corrections, and retest until the pressure drop requirement can be met.

Only if several consecutive tests indicate a consistent pressure drop and only after the Contractor has made numerous attempts to resolve the problem, acceptable to the Engineer, may the Contractor request in writing and the Engineer consider the use of the leakage test. The leakage test may be performed by the Contractor to determine the magnitude of the leak, however, meeting the leakage allowance shall not automatically be considered acceptance, in lieu of the pressure test, for the section being tested. Final acceptance shall be at the discretion of the Engineer.

When allowed, the leakage test shall be performed in accordance with AWWA C600.

## **H Operational Inspection**

At the completion of the project and in the presence of the Engineer and the Contractor, representatives of the Owner shall operate all valves, hydrants, and water services to ascertain that the entire facility is in good working order; that all valve boxes are centered and valves are opened; that all hydrants operate and drain properly; that all curb boxes are plumb and centered; and that water is available at all curb stops.

## **2611.4 METHOD OF MEASUREMENT**

All items will be measured separately according to design designation as indicated in the Pay Item name and as may be detailed and defined in the Plans, Specifications, or Special Provisions. Pipe will generally be designated by size (inside diameter or span), strength class, kind or type, and laying condition. Payment shall include all component parts thereof as described or required to complete the unit, but excluding any item covered by a separate pay item. Lineal measurement of piping will include the running length of any special fittings (tees, wyes, bends, gates, etc.) installed within the line of measure between specified terminal points.

### **A Water Pipe**

Mainline pipe and service pipe of each kind and size will be measured separately by the overall length along the axis of the pipeline, from beginning to end of each installation and without regard to intervening valves or specials. Terminal points of measure will be the spigot or cut end, base of hub or bell end, center of valves or hydrants, intersecting centers of tee or wye branch service connections, and center of corporation stop or curb stop couplings.

### **B Valves**

Valves of each size and type will be measured separately as complete units, including the required manhole or valve box setting.

### **C Corporation Stops**

Corporation stops of each size and type will be measured separately by the number of units installed, including the watermain tap and saddle.

## **D Curb Stops**

Curb stops of each size and type will be measured separately by the number of units installed, including the required curb box.

## **E Hydrants**

Hydrants will be measured by the number of units installed.

## **F Air Vents**

Air vents of each type and size will be measured separately by the number of complete units installed, including the required manhole or valve box setting.

## **G Polyethylene Encasement**

Polyethylene encasement of pipe will be measured by the linear foot of pipe encased of each specified size.

## **H Ductile and Gray Iron Fittings**

Ductile Iron and Gray Iron fittings shall be measured by the pound without joint accessories or on an each basis as specified on the Proposal or in the Special Provisions. Joint accessories including tie rods, joint restraints, nuts and bolts shall be incidental to the watermain unless otherwise provided on the Proposal or in the Special Provisions.

The standard weight of Ductile Iron and Gray Iron fittings, for payment basis, shall be as published in AWWA C153 and C110, respectively.

## **I Polyvinyl Chloride or Polyethylene**

Polyvinyl Chloride or Polyethylene fittings shall be measured on an each basis as specified and shown on the Proposal or in the Special Provisions.

## **J Access Structures**

Access structures, such as valve boxes, service boxes, manholes and vaults, will be measured for payment only when and to the extent that the Proposal contains specific items therefore. Otherwise, the required structures are included for payment as part of the pipe appurtenance (Gate Valve, Curb Stop, Air Vent, etc.) item which is served. When applicable, measurement will be by the number of individual units installed of each type and design.

## **2611.5 BASIS OF PAYMENT**

Payment for construction of water distribution facilities will be made as detailed in the method of measurement and as shown on the Bid Proposal or detailed in the Special Provisions. Payment shall include all costs of furnishing and installing the complete facility as required by the Plans, Specifications, and Special Provisions.

Payment shall be made for Watermain Pipe, Service Pipe, and Tapped Service Pipe, of each size and kind at the appropriate Contract prices per linear foot installed. All costs of pipeline disinfection, leakage testing, pipe jointing materials, dead end plugs and caps, making connections to existing facilities, blocking and anchorage materials, and other work necessary for proper installation of pipe as specified shall be included for payment as part of the pipe item, without any direct compensation being made therefore unless specific pay items are included on the Proposal.

Payment shall be made for Valves, Corporation Stops, Curb Stops, Hydrants, Air Vents, Polyethylene Encasement, Insulation, and other specially identified appurtenant items, at the appropriate Contract prices per unit of measure for each size and type or kind installed.

Access structures such as Valve Boxes, Service Boxes, Manholes, and Vaults will be paid for as separate items only when separate pay items are included on the Proposal. Payment for rearrangement of in-place facilities or vertical offset of proposed facilities shall be made under specially named items at the appropriate Contract prices per unit of measure and shall be compensation in full for all costs of performing the work as specified.

All costs of excavating to foundation grade, preparing the foundation, placing and compacting backfill materials, restoring surface improvements, and other work necessary for prosecution and completion of the work as specified, shall be included for payment as part of the pipe and pipe appurtenance items without any direct compensation being made therefore, unless specific pay items are included on the Proposal.

Watermain connections shall be paid per each connection to new watermain. All necessary labor, materials, and work required to make the connection shall be included in the price per each as provided in the bid proposal.

Installation of tracer wire for thermoplastic and other non-conductive pipe materials shall be considered incidental with no direct compensation made thereto, except where noted otherwise.

## **SECTION 2621 – STANDARD SPECIFICATIONS FOR SANITARY SEWER AND STORM SEWER INSTALLATION**

### **2621.1 DESCRIPTION**

This work shall consist of the construction of pipe sewers utilizing plant fabricated pipe and other appurtenant materials, installed for conveyance of sewage, industrial wastes, or storm water. The work includes construction of manhole and catch basin structures and other related items as specified.

The use of the term "Plans, Specifications and Special Provisions" within this specification shall be construed to mean those documents which compliment, modify, or clarify these specifications and are an enforceable component of the Contract Documents.

All references to MnDOT Specifications shall mean the latest published edition of the Minnesota Department of Transportation "Standard Specifications for Construction", and all supplements and amendments thereto published prior to the date of advertisement for bids.

All references to other Specifications of AASHTO, ASTM, ANSI, AWWA, etc. shall mean the latest published edition available on the date of advertisement for bids.

The following specifications have been referenced in this Specification:

AASHTO M198 Standard Specification for Joints for Concrete Pipe, Manholes, and Precast Box Sections Using Preformed Flexible Joint Sealants

AASHTO M294 Standard Specification for Corrugated Polyethylene Pipe, 300-mm to 1500-mm (12-in. to 60-in.) Diameter

ASTM A48 Standard Specification for Gray Iron Castings

ASTM A74 Standard Specification for Cast Iron Soil Pipe and Fittings

ASTM A798 Standard Practice for Installing Factory Made Corrugated Steel Pipe for Sewers and Other Applications

ASTM C12 Standard Practice for Installing Vitrified Clay Pipe Lines

ASTM C76 Standard Specification for Reinforced Concrete Culvert, Storm Drain, and Sewer Pipe

ASTM C270 Standard Specification for Mortar for Unit Masonry

ASTM C301 Standard Test Methods for Vitrified Clay Pipe

ASTM C361 Standard Specification for Reinforced Concrete Low Head Pressure Pipe

ASTM C425 Standard Specification for Compression Joints for Vitrified Clay Pipe and Fittings

ASTM C443 Standard Specification for Joints for Concrete Pipe and Manholes Using Rubber Gaskets

ASTM C478 Standard Specification for Circular Precast Reinforced Concrete Manhole Sections

ASTM C564 Standard Specification for Rubber Gaskets for Cast Iron Soil Pipe and Fittings

ASTM C700 Standard Specification for Vitrified Clay Pipe, Extra Strength, Standard Strength, and Perforated

ASTM C969 Standard Practice for Infiltration and Exfiltration Acceptance Testing of Installed Precast Concrete Pipe Sewer Lines

ASTM C1479 Standard Practice for Installation of Precast Concrete Sewer, Storm Drain, and Culvert Pipe Using Standard Installations

ASTM D543 Standard Practice for Evaluating the Resistance of Plastics to Chemical Reagents

ASTM D2321 Standard Practice for Underground Installation of Thermoplastic Pipe for Sewers and Other Gravity Flow Applications

ASTM D2751 Standard Specification for Acrylonitrile-Butadiene-Styrene (ABS) Sewer Pipe and Fittings (Withdrawn 2014)

ASTM D3034 Standard Specification for Type PSM Poly(Vinyl Chloride) (PVC) Sewer Pipe and Fittings

ASTM D3212 Standard Specification for Joints for Drain and Sewer Plastic Pipes Using Flexible Elastomeric Seals

ASTM D3262 Standard Specification for "Fiberglass" (Glass Fiber Reinforced Thermosetting Resin) Sewer Pipe

ASTM D3839 Standard Guide for Underground Installation of "Fiberglass" (Glass Fiber Reinforced Thermosetting Resin) Pipe

ASTM D4161 Standard Specification for Fiberglass (Glass Fiber Reinforced Thermosetting Resin) Pipe Joints Using Flexible Elastomeric Seals

ASTM F477 Standard Specification for Elastomeric Seals (Gaskets) for Joining Plastic Pipe

ASTM F679 Standard Specification for Poly(Vinyl Chloride) (PVC) Large-Diameter Plastic Gravity Sewer Pipe and Fittings

ASTM F949 Specification for Poly (Vinyl Chloride) (PVC) Corrugated Sewer Pipe with a Smooth Interior and Fittings

ASTM F1417 Standard Practice for Installation Acceptance of Plastic Non pressure Sewer Lines Using Low Pressure Air

ASTM F2764 Standard Specification for 6 to 60 in. [150 to 1500 mm] Polypropylene (PP) Corrugated Double and Triple Wall Pipe and Fittings for Non-Pressure Sanitary Sewer Applications

ASTM F3219 Standard Specification for 3 to 30 in. (75 To 750 mm) Polypropylene (PP) Corrugated Single Wall Pipe and Fittings

AWWA C104 American National Standard for Cement-Mortar Lining for Ductile-Iron Pipe and Fittings

AWWA C110 Standard for Ductile-Iron and Gray-Iron Fittings

AWWA C111 Standard for Rubber-Gasket Joints for Ductile-Iron Pressure Pipe and Fittings

AWWA C115 Standard for Flanged Ductile-Iron Pipe With Ductile-Iron or Gray-Iron Threaded Flanges

AWWA C116 Standard for Protective Fusion-Bonded Coatings for the Interior and Exterior Surfaces of Ductile-Iron and Gray-Iron Fittings

AWWA C150 Standard for Thickness Design of Ductile-Iron Pipe

AWWA C151 Standard for Ductile-Iron Pipe, Centrifugally Cast

AWWA C153 Standard for Ductile-Iron Compact Fittings

AWWA C550 Standard for Protective Interior Coatings for Valves and Hydrants

## **2621.2 MATERIALS**

All materials required for this work shall be new material conforming to requirements of the referenced specifications for the class, kind, type, size, grade, and other details indicated in the Contract. Unless otherwise indicated, all required materials shall be furnished by the Contractor. If any options are provided for, as to type, grade, or design of the material, the choice shall be limited as may be stipulated in the Plans, Specifications, or Special Provisions.

All manufactured products shall conform in detail to such standard design drawings as may be referenced or furnished in the Plans. Otherwise, the Owner may require advance approval of material suppliers, product design, or other unspecified details as it deems desirable for maintaining adopted standards.

At the request of the Engineer, the Contractor shall submit in writing a list of materials and suppliers for approval. Suppliers shall submit a Certificate of Compliance that the materials furnished have been tested and are in compliance with the specifications.

## **A Sewer Pipe and Service Line Materials**

All pipe furnished for main sewer and service line installations shall be as indicated for each particular line segment as shown in the Plans and designated in the Contract Items. Wherever connection of dissimilar materials or designs is required, the method of joining and any special fittings employed shall be products specifically manufactured for this purpose and subject to approval by the Engineer.

### **A1 Vitrified Clay Pipe and Fittings**

Vitrified clay extra strength pipe and fittings shall conform to the requirements of ASTM C700 for the size and type and class specified, subject to the following supplementary provisions:

- (1) Unless otherwise specified, the pipe and fittings shall be non-perforated, full circular type, either glazed or unglazed.
- (2) All pipe and fittings manufactured with bell-and-spigot ends shall be furnished with factory fabricated compression joints conforming to the requirements of ASTM C425.
- (3) In lieu of the bell-and-spigot jointing requirements, the pipe and fittings may be furnished with plain ends, in which case the jointing shall be by means of compression couplings conforming to the requirements of ASTM C425, Type B.
- (4) All clay pipe fittings (wyes, tees, bends, plugs, etc.) shall be of the same pipe class and joint design as the pipe to which they are to be attached.

### **A2 Ductile Iron Pipe and Ductile Iron and Gray Iron and Fittings**

The pipe furnished shall be Ductile Iron pipe and pipe fittings furnished shall be of the Ductile Iron or Gray Iron type as specified for each particular use of installation. When Gray Iron is specified, either type may be furnished. Gray Iron may not be substituted for Ductile Iron unless specifically authorized in the Special Provisions.

Ductile iron pipe shall conform to the requirements of AWWA C115 or C151 for water, and thickness design shall conform to AWWA C150. In addition, the pipe shall comply with the following supplementary provisions:



- (1) Fittings shall conform to the requirements of AWWA C110 (Gray Iron and Ductile Iron Fittings) or AWWA C153 (Ductile Iron Compact Fittings) for the joint type specified.
- (2) Unless otherwise specified all pipe and fittings shall be furnished with cement mortar lining meeting the requirements of AWWA C104 for standard thickness lining. All exterior surfaces of the pipe and fittings shall have an asphaltic coating at least one mil thick. Spotty or thin seal coating, or poor coating adhesion, shall be cause for rejection.

Fittings specified to be furnished with fusion bonded epoxy external coating and/or interior lining shall conform to the requirements of AWWA C550 and C116/A21.16, with 6-8 mil nominal thickness.

- (3) Rubber gasket joints for Ductile Iron Pressure Pipe and fittings shall conform to AWWA C111.
- (4) The nuts and bolts shall be constructed of corrosion resistant, high-strength, low-alloy steel with a ceramic filled, baked on fluorocarbon resin. The nuts and bolts shall be in compliance with ANSI/AWWA C111/A21.11.
- (5) Conductivity, when required by the Special Provisions, shall be maintained through pipe and fittings with an external copper jumper wire or specialty gaskets which are capable of meeting conductive requirements. Wedge type connectors will not be allowed.

### **A3 Reinforced Concrete Pipe and Fittings**

Reinforced concrete (RC) pipe, fittings and specials shall conform to the requirements of MnDOT 2501, 2503, 3236, and ASTM C76 (Reinforced Concrete Pipe) with rubber O-ring or profile joints for the type, size, and strength class specified, subject to the following supplementary provisions:

- (1) All branch fittings such as tees, wyes, etc. shall be cast as integral parts of the pipe. All fittings and specials shall be of the same strength class as the pipe to which they are attached.
- (2) Joints shall meet the requirements of ASTM C361, and ASTM C443.
- (3) Lift holes will not be permitted unless specifically authorized in the Plans, Specifications, and Special Provisions

#### **A4 Corrugated Steel Pipe and Fittings**

Corrugated Steel (CS) Pipe and fittings shall conform to the requirements of MnDOT 2501, 2503, and 3226 (CS) Pipe for the application, type, size and sheet thickness specified. Joints for joining CS Pipe shall be the band type or bell/spigot type, soil-tight and watertight, with preformed gasket seals meeting MnDOT 3726. Fittings and bands for joining pipe sections shall be of the same material and thicknesses as the mainline pipe.

Specialty coatings for the pipe shall be as indicated in the Plans, Specifications, and Special Provisions.

#### **A5 Polyvinyl Chloride Pipe and Fittings**

Smooth walled polyvinyl chloride pipe and fittings shall conform to the requirements of ASTM D3034 and ASTM F679 for the size, standard dimension ratio (SDR), and strength requirements indicated on the Plans, Specifications, and Special Provisions. The grade used shall be resistant to aggressive soils or corrosive substances in accordance with the requirements of ASTM D543.

Pipe fittings shall be of the same class and grade as specified for the pipe, unless otherwise specified in the special provisions.

Unless otherwise specified, all pipe and fittings shall be SDR 35 and connections shall be push-on with elastomeric gasket joints which are bonded to the inner wall of the gasket recess of the bell socket.

PVC pipe and fittings for pressure sewer and forcemains shall meet the requirements of 2611.2 A3 for watermain class pipe.

Corrugated polyvinyl chloride pipe and fittings with smooth interior shall conform to the requirements of ASTM F949 for the size and wall thickness indicated on the Plans, Specifications, and Special Provisions. Unless otherwise specified, all pipe and fittings shall be push-on with snug fit elastomeric joints meeting tightness requirements of ASTM D3212 and ASTM F477.

#### **A6 Cast Iron Soil Pipe**

Unless otherwise specified in the Plans, Specifications, and Special Provisions, cast iron soil pipe shall be service weight pipe meeting the requirements of ASTM A74 and the Plans, Specifications, and Special Provisions. Unless otherwise specified, pipe joints shall be push-on, sealed with elastomeric gaskets, meeting the requirements of ASTM C564.

## **A7 Acrylonitrile-Butadiene-Styrene Pipe**

Acrylonitrile-Butadiene-Styrene (ABS) solid wall pipe and fittings shall conform to the requirements of ASTM D2751 (Withdrawn 2014) and shall be gasket seal joints, assembled as recommended by the pipe manufacturer. Unless otherwise specified, all pipe and fittings shall be push-on with snug fit elastomeric joints meeting tightness requirements of ASTM D3212 and ASTM F477. Solvent cemented joints, assembled as recommended by the pipe manufacturer, shall be provided only where specifically indicated in the Plans, Specifications, and Special Provisions.

## **A8 Corrugated Polyethylene Pipe**

Dual-Wall and Triple-Wall Corrugated Polyethylene Pipe (PE/HDPE) for gravity sewers shall conform to the requirements of AASHTO M294 for storm sewer pipe sizes twelve inch (12") through sixty inch (60"). Joints shall be bell and spigot push-on type, soil-tight and watertight joints in accordance with ASTM D3212 and ASTM F477. Pipe manufacture, watertight joint testing, and installation shall conform to MnDOT 2501, 2503, 3247, ASTM C969, and as indicated in the Plans, Specifications, and Special Provisions.

## **A9 Solid Wall High Density Polyethylene Pipe**

Solid wall HDPE for pressure and gravity sewer pipes shall meet the requirements of 2611.2A4.

## **A10 Fiberglass Reinforced Pipe**

Fiberglass Reinforced Pipe (FRP/GRP) for gravity sewers shall meet requirements of ASTM D3262 for Glass-Fiber-Reinforced Thermosetting Resin pipe, such as reinforced thermosetting-resin pipe (RTRP) and reinforced polymer mortar pipe (RPMP; natural polymers not included) for use in gravity-flow systems. The pipe shall be manufactured with polyester resin systems with a proven history of performance in this application.

The reinforcing glass fibers used to manufacture the components shall be of highest quality commercial grade E-glass filaments with binder and sizing compatible with impregnating resins.

Sand used to manufacture the pipe and fittings shall be minimum ninety eight percent (98%) silica sand with a maximum moisture content of two tenths of a percent (0.2%).

Pipe resin additives, such as curing agents, pigments, dyes, fillers, thixotropic agents, etc., when used, shall not detrimentally effect the performance of the products.

Gaskets shall be supplied by approved gasket manufacturers and be suitable for the service intended. Minimum pressure rating of gaskets shall be two hundred fifty (250) psi.

Unless otherwise specified, the pipe shall be field connected with fiberglass sleeve couplings that utilize elastomeric sealing gaskets made of EPDM rubber compound to provide watertight joints meeting the requirements of ASTM D4161. Joints at tie-ins, when needed, may utilize fiberglass, gasket-sealed closure couplings.

Fittings shall be capable of withstanding all operating conditions when installed. They may be contact molded or manufactured from mitered sections of pipe joined by glass-fiber-reinforced overlays. Properly protected standard ductile iron, fusion-bonded epoxy-coated steel and stainless steel fittings are allowed unless otherwise stated in the Special Provisions.

The actual outside diameter (eighteen inch (18") to forty eight inch (48")) of the pipes shall be in accordance with ASTM D3262. Other pipe diameter OD's shall be per manufacturer's literature.

Pipe shall be supplied in nominal lengths of twenty feet (20') except where noted otherwise on the drawings. Actual laying length shall be nominal  $\pm 1/4$  inches. At least ninety percent (90%) of the total footage of each size and class of pipe, excluding special order lengths, shall be furnished in nominal length sections.

Pipe ends shall be square to the longitudinal pipe axis with a maximum tolerance of **one-eighth** inch (1/8").

Pipe shall be marked identifying each pipe with the name of manufacturer, plant location, code date of manufacturer, nominal pipe size, pipe stiffness designation and ASTM D3262.

Service lateral connections (wye, tee, bend) to the sanitary sewer shall be as recommended by the main line sewer pipe manufacturer recommendation.

### **A11 Polypropylene Pipe**

Corrugated Polypropylene Pipe (PP) for gravity sewers shall conform to ASTM F2881. Pipe joints shall be bell and spigot push-on type, soil-tight and watertight joints in accordance with ASTM D3212 and ASTM F477, and shall conform to the requirements of AASHTO M330 dual wall Type "S" pipe for storm sewer pipe sizes twelve inch (12") through sixty inch (60"). Pipe manufacture, watertight joint testing, and installation shall conform to current MnDOT requirements, ASTM F1417, and as indicated in the Plans, Specifications, and Special Provisions.

### **A12 Tracer Wire for Non-conductive Pipe**

Tracer wire for use with all thermoplastic pipe types shall be Underwriters Laboratories (UL) listed for use in direct burial applications, color coated per APWA uniform color code for the specific utility being marked. Tracer wire shall be a minimum 12 AWG copper clad steel rated to 30 volts, insulation shall be High Molecular Weight Polyethylene (HMWPE) meeting ASTM D1248, with designation identified on the outside of the wire casing.

Tracer wire shall meet the following additional criteria for the construction method specified:

Open Trench - Trace wire shall be High Strength with minimum 450 lb. break load, with minimum 30 mil HDPE insulation thickness.

Directional Drilling/Boring - Trace wire shall be Extra High Strength with minimum 1,150 lb. break load, with minimum 30 mil HDPE insulation thickness.

Pipe Bursting/Slip Lining - Trace wire shall be 7 x 7 Stranded Copper Clad Steel, Extreme Strength with 4,700 lb. break load, with minimum 50 ml HDPE insulation thickness.

Connectors for tracer wire shall meet the following:

All mainline trace wires must be interconnected at tees and crosses, joined using a single 3-way or 4-way lockable connector for tees and crosses, respectively.

Lockable connectors shall be for direct bury application, and shall be dielectric silicon filled to seal out moisture and corrosion.

## **B Metal Sewer Castings**

Metal castings for sewer structures such as manhole frames and covers, catch basin frames, grates and curb boxes, shall conform to the requirements of ASTM A48 (Gray Iron Castings), subject to the following supplementary provisions:

- (1) Casting assemblies or dimensions, details, weights, and class shall be as indicated in the detailed drawings for the design designation specified. Unless otherwise specified, the castings shall be Class 30 or better.
- (2) Lid-to-frame surfaces on round casting assemblies shall be machine milled to provide true bearing around the entire circumference.
- (3) Casting weight shall be not less than ninety five percent (95%) of theoretical weight for a unit cast to exact dimensions, based on four hundred forty two (442) pounds per cubic foot.
- (4) A Certificate of Compliance shall be furnished with each shipment of castings stating that the materials furnished have been tested and are in compliance with the specification requirements.
- (5) Unless otherwise specified, sanitary sewer manholes shall have self-sealing lids and concealed pick holes.

## **C Precast Concrete Manhole and Catch Basin Sections**

Precast concrete riser sections and appurtenant units (grade rings, top and base slabs, special sections, etc.) used in the construction of manhole and catch basin structures shall conform with the requirements of ASTM C478, MnDOT 2506 and the following supplementary provisions:

- (1) The precast sections and appurtenant units shall conform to all requirements as shown on the detailed drawings.
- (2) Joints of manhole riser sections shall be tongue and groove with rubber "O" ring or profile gaskets conforming to the requirements of ASTM C443..

- (3) Sanitary sewer inlet and outlet pipes shall be joined to the manhole with a gasketed, flexible, watertight connection, watertight boot, or any watertight connection arrangement approved by the Engineer that allows differential settlement of the pipe and manhole wall to take place.
- (4) Air-entrained concrete shall be used in the production of all wet-cast units. Air content shall be maintained within the range of five (5) to eight (8) percent (%).
- (5) A Certificate of Compliance shall be furnished with each shipment of precast manhole and catch basin sections stating that the materials furnished have been tested and are in compliance with the specification requirements.
- (6) Lift holes will not be permitted in precast manholes.

#### **D Mortar**

Mortar for use in masonry construction shall meet the requirements of MNDOT 2506.2B and ASTM C270.

#### **E Concrete**

Concrete used for cast-in-place masonry construction shall be produced and furnished in accordance with the provisions of MnDOT Specification 2461, Table 2461-6, for the mix design indicated in the Plans, Specifications, or Special Provisions. Type 3, air-entrained, concrete shall be furnished and used in all structures having weather exposure.

### **2621.3 CONSTRUCTION REQUIREMENTS**

#### **A Installation of Pipe and Fittings**

The Contractor shall take all necessary precautions to handle and install all pipe and appurtenances as recommended by the manufacturer, Engineer, Plans, Specifications, and the Special Provisions.

Installation of PVC pipe and fittings for pressure sewer and forcemains shall meet the requirements of 2611.3 for watermain class pipe.

#### **A1 Inspection and Handling**

Proper and adequate implements, tools, and facilities satisfactory to the Engineer shall be provided and used by the Contractor for the safe and convenient prosecution of the work. During the process of unloading, all pipe and accessories shall be inspected by the Contractor for damage. The Contractor shall notify the Engineer of all material found to have cracks, flaws or other defects. The Engineer shall inspect the damaged materials and have the right to reject any materials found to be unsatisfactory. The Contractor shall promptly remove all rejected material from the site. All materials shall be handled carefully, as will prevent damage to protective coatings, linings, and joint fillings; preclude contamination of interior areas; and avoid jolting contact, dropping, or dumping.

All work and materials are subject to tests by the Owner at such frequency as may be determined by the Engineer.

While suspended and before being lowered into laying position, each pipe section and appurtenant unit shall be inspected by the Contractor to detect damage or unsound conditions that may need corrective action or be cause for rejection. The Contractor shall inform the Engineer of any defects discovered and the Engineer will prescribe the required corrective actions or order rejection.

Immediately before placement, the joint surfaces of each pipe section and fitting shall be inspected for the presence of foreign matter, coating blisters, rough edges or projections, and any imperfections so detected shall be corrected by cleaning, trimming, or repair as needed.

### **A2 Pipe Laying Operations**

Trench excavation and bedding preparations shall proceed ahead of pipe placement as will permit proper laying and joining of the units at the prescribed grade and alignment without unnecessary deviation or hindrance.

All foreign matter or dirt shall be removed from the inside of the pipe and fittings before they are lowered into position in the trench and they shall be kept clean. The sewer materials shall be carefully lowered into laying position by the use of suitable restraining devices. Under no circumstances shall the pipe be dropped into the trench.

Unless otherwise permitted by the Engineer, bell and spigot pipe shall be laid with the bell ends facing upgrade and the laying shall start on the downgrade end and proceed upgrade. As each length of bell and spigot pipe is placed in laying position, the spigot end shall be centered in the bell and the pipe forced home and brought to correct line and grade. The pipe shall be secured in place with approved backfill material.

Connection of pipe to existing lines or previously constructed manholes or catch basins shall be accomplished as shown in the Plans or as otherwise approved by the Engineer. Where necessary to make satisfactory closure or produce the required curvature, grade or alignment, deflections at joints shall not exceed that which will assure watertight joints and shall comply with the pipe manufacturer recommendations.

Entrance of foreign matter into pipeline openings shall be prevented at all times to the extent that suitable plugs or covering can be kept in place over the openings without interfering with the installation operations.

Installation of thermoplastic pipe shall conform to ASTM D2321; FRP/GRP pipe to ASTM D3839, and the manufacturers' recommendations; ASTM A798 for CS pipe, and ASTM C1479 for RC pipe.

### **A3 Connection and Assembly of Joints**

All pipe and fitting joints shall fit tightly and be fully closed. Spigot ends shall be marked as necessary to indicate the point of complete closure. All joints shall be soil tight and watertight in all sanitary sewer and storm sewer pipe.

#### **A4 Bulkheading Open Pipe Ends**

All pipe and fitting ends left open for future connection shall be bulkheaded by approved methods prior to backfilling. Unless otherwise specified or approved, all openings of twenty four inches (24") in diameter or less shall be closed off with prefabricated plugs or caps and all openings larger than twenty four inches (24") in diameter shall be closed off with masonry bulkheads.

Prefabricated plugs and caps shall be of the same material as the pipe material, or an approved alternate material, and they shall be installed with watertight seal as required for the pipeline joints. Masonry bulkheads shall be constructed with clay or concrete brick to a wall thickness of eight inches (8").

Bulkheads installed for temporary service during construction may be constructed with two inch (2") timber planking securely fastened together and adequately braced, as an alternate to the masonry construction.

#### **A5 Tracer Wire**

Tracer wire shall be installed along the length of all non-conductive mainline pipe, laterals, and services with vertical riser to the surface, at manholes, catch basins, stubs, laterals, services, and/or utility location boxes as required by the Special Provisions. Tracer wire shall be taped, clamped or affixed to the pipe in another manner as approved by the Engineer.

Splicing tracer wire shall be by mechanical split bolt type or a crimp type compression fitting fully encased in approved electrical insulation putty. A twelve inch (12") tracer wire loop shall be provided on each side of a spliced connection.

Tracer wire lengths greater than 500 linear feet are to include an approved grade level/in-ground access box, located at the edge of the road right-of-way and outside of the roadway.

Tracer wire shall be grounded at all terminal ends (stubs, plugs).

#### **B Appurtenance Installations**

Appurtenance items such as aprons, trash guards, gates and castings shall be installed where and as required by the Plans and in accordance with such standard detail drawings or supplementary requirements as may be specified.

Casting assemblies installed on manhole or catch basin structures shall be set in a full mortar bed and be adjusted to the specified elevation without the use of shims or blocking.

Sewer aprons shall be subject to all applicable requirements for installation of pipe. All aprons and outfall end sections shall have the last three (3) sections tied. Two (2) tie bolt fasteners shall be placed in each of the last three joints, one on each side of top center at the sixty (60) degree point (from vertical). Tie bolt diameter shall be: 5/8 inch for 12" to and including 27" pipe; 3/4 inch for 30" to and including 66" pipe; 1 inch for 72" to and including 144" pipe. The tie bolts shall be of a design approved by the Engineer.



## **C Sewer Service Installations**

Main sewer service connections and building service sewer pipe shall be installed as provided for in the Contract and as may be directed by the Engineer. The sewer service connections and pipe lines shall be installed in conformance with all applicable requirements of the main sewer installation and as more specifically provided for herein.

The Engineer, with the assistance of the Contractor, shall keep accurate records of all service installations as to type, location, elevation, point of connection and termination, etc. This service record shall be maintained jointly by the Contractor and Engineer on forms provided by the Engineer. The service installations shall not be backfilled until all required information has been obtained and recorded.

The main sewer service connection shall consist of installing a Branch Tee or Wye section in the main sewer line at designated locations or providing an insert type Saddle Tee or Wye fitting in a pipe cut-out where specified. Orientation of service connection fitting shall be as shown in the standard drawings unless otherwise directed by the Engineer.

Where the depth of cover over the main sewer invert is greater than fifteen (15) feet (or such other maximum as may be indicated), the service connection shall be extended upward by means of a Service Riser Section.

Unless otherwise specified, service pipe shall be installed at right angles to the main sewer and at a straight line grade to the property line. The standard and minimum grades shall be a uniform rise of one inch (1") in four feet (4') (two percent (2%)) for sanitary service lines and one inch (1") in eight feet (8') (one percent (1%)) for storm sewer service lines. These minimum grades may be reduced (by not more than one-half (1/2) pitch) where the Engineer so approves in the case of restrictive elevation differences.

Building service pipe lines shall generally be kept as deep as required to serve the building elevation and maintain the specified minimum pipe grades. Pipe bends shall be provided as necessary to bring the service lines to proper location and grade. Pipe bends shall not exceed twenty-two and one half (22-1/2) degrees without approval of the Engineer.

Unless otherwise indicated, service pipe installation shall terminate at property line or as designated on the Plans, with a gasketed plug placed in the end, at which point the Contractor shall furnish and set a four inch by four inch (4" x 4") wooden timber six feet (6') to eight feet (8') in length embedded four feet (4') below grade, or approved steel post to mark the exact end of pipe. The timber or post shall be set vertically, with the top two feet (2') painted green.

Wherever service line connections to the main sewer are permitted or required to be made by the open cut-out method in the absence of a built-in Tee or Wye fitting, the connection shall be made by using an approved type of Saddle Tee or Wye fitting. The pipe cut-out shall be made with an approved type coring machine or by other approved methods producing a uniform, smooth circular cut-out as required for proper fit. The cut-out discs shall be retrieved and shall not be allowed to remain within the main sewer pipe. The Saddle Tee shall be securely fastened to the main sewer pipe by means of epoxy resin or other approved adhesive. The entire connection fitting shall be encased in concrete to a minimum thickness of six inches (6") and as may be shown in the standard drawings.

Wherever service line connections to the main sewer are required to be made by means of built-in Branch Tee or Wye fittings, the Contractor shall, in the absence of such fitting, remove a section of the main sewer pipe and replace it with the required Branch Tee or Wye section connected by means of an approved sleeve coupling.

Sanitary sewer service lines shall not be connected to a manhole at an elevation more than twenty-four inches (24") above the crown of the outgoing sewer. Where the elevation difference is greater than twenty-four inches (24"), the connection shall be made by means of an Outside Drop Connection in accordance with the details shown in the standard drawings.

All pipe and fitting openings at temporary terminal points shall be fitted with suitable plugs or shall be bulkheaded as required for the main sewer pipe.

#### **D Manhole and Catch Basin Structures**

Manholes, catch basins, and other special access structures shall be constructed at designated locations as required by the Plans and in accordance with any standard detail drawings or special design requirements given therefor.

Unless otherwise specified or approved, storm sewer manholes and catch basins shall be constructed on a precast or cast-in-place concrete base and the barrel riser sections, and cone section shall all be of precast concrete. Sanitary sewer manholes shall be constructed with precast concrete integral base with pre-formed invert barrel section and with watertight boots at all pipe locations. All units shall be properly fitted and sealed to form a completely watertight structure. Manholes and catch basin structures shall be fabricated to provide a twelve-inch (12") or sixteen inch (16") barrel section immediately below the cone or top slab whenever possible. Barrel and cone height shall be such as to permit placement of at least two (2) and not more than six (6) standard two-inch (2") precast concrete or high density polyethylene adjusting immediately below the casting assembly. Sanitary manhole adjustment rings and casting flange shall be fitted with specified method/materials as indicated in the Special Provisions to reduce inflow and infiltration. Storm sewer manhole and drainage structure adjustment rings and casting flange shall be wrapped with a Type 2 Geotextile fabric meeting MnDOT 3733.

Unless otherwise specified or approved, manholes and catch basins shall have an inside barrel diameter at the bottom of forty-eight inches (48") minimum and the inside diameter at the top of the cone section and all adjusting rings shall be of the same size and shape as the casting frame. Casting assemblies shall be as specified in the Plans

Concrete cast-in-place base shall be poured on undisturbed or firmly compacted foundation material which shall be trimmed to proper elevation. The bottom riser section shall be set in fresh concrete or mortar and all other riser section joints of the tongue and groove design shall be sealed with rubber gaskets. The concrete base under an outside drop connection shall be monolithic with the manhole base.

Wherever special designs so require or permit, and as may be approved by the Engineer, a precast concrete base may be used or the structure may be constructed with solid sewer brick or block units or with cast-in-place concrete. Any combination of cast-in-place concrete and brick or block mortar construction will be allowed and may be required where it is impossible to complete the construction with standard precast manhole sections.

All manhole and catch basin structure doghouses shall be completely filled with mortar, concrete masonry, or concrete to completely seal the pipes into the structure wall. When formed inverts are specified, the inside bottom of each manhole and catch basin shall be shaped with fresh concrete to form free flow invert troughs.

When connecting to an existing sanitary sewer manhole without an existing opening for sewer pipe, the Contractor shall be required to core-drill an opening of the correct size and elevation for the proposed sanitary sewer facility. The Contractor shall set the connecting pipe through the full thickness of the wall flush with the inner face of the wall. Connection to the structure shall be made with a watertight joint, by means of a rubberized boot. The Contractor shall ensure the flow line of the manhole is constructed in a manner to provide steady flow from the new sanitary line to the existing sanitary line. The flow line and the core-drilled hole are to be grouted smooth. The Contractor shall install a plug in the connecting pipe once the connection is complete and construction has advanced to the next manhole to prevent rainwater or sediment from entering the existing system. The plug shall be removed once all the proposed sanitary sewer mains on the project have been installed, tested, inspected, and approved.

## **E Sanitary Sewer Leakage Testing**

All sanitary sewer lines, including service connections, shall be substantially watertight and shall be tested for excessive leakage upon completion and before connections are made to the service by Others. Each test section of the sewer shall be subjected to exfiltration testing, either by hydrostatic or air test method as described below and at the Contractor's option. The requirements set forth for maximum leakage shall be met as a condition for acceptance of the sewer section represented by the test.

If the ground water level is greater than three feet above the invert elevation of the upper manhole and the Engineer so approves, infiltration testing may be allowed in lieu of the exfiltration testing, in which case the allowable leakage shall be the same as would be allowed for the Hydrostatic Test.

All testing shall be performed by the Contractor without any direct compensation being made therefore, and the Contractor shall furnish all necessary equipment and materials, including plugs and standpipes as required.

### **E1 Air Test Method**

#### *E1a Gravity Sewers*

All gravity sanitary sewer lines, including service connections, shall be substantially watertight and shall be tested for excessive leakage upon completion and before connections are made to the service by Others. Each test section of the sewer shall be subjected to exfiltration testing by the ASTM F1417 (low pressure air) test method regardless of pipe material.

The requirements set forth for maximum leakage shall be met as a condition for acceptance of the sewer section represented by the test. All testing shall be performed by the Contractor without any direct compensation being made therefore, and the Contractor shall furnish all necessary equipment and materials, including plugs and standpipes as required.

The sewer pipe section under test shall be clean at the time of testing but the pipe may be wetted. Pneumatic balls shall be used to plug the pipe ends at manholes. Low pressure air shall be introduced to the plugged line until the internal air pressure reaches three and one half (3.5) psi greater than the average back pressure of any ground water pressure that may submerge the pipe. At least two (2) minutes shall be allowed for the air temperature to stabilize before readings are taken and the timing started. During this time the Contractor shall check all plugs to detect plug leakage. If plugs are found to leak, air shall be bled off, the plugs shall be retightened, and the air shall be reintroduced into the line.

The sewer section under test will be accepted as having passed the air leakage test when the rate of air loss as measured by pressure drop, does not exceed a specified amount in a specified time. Pressure drop may be determined by using the table below, or calculated by use of the formulas provided below.

**TABLE**  
**Minimum Specified Time Required for a 0.5 psig Pressure Drop for Size and Length of Pipe Indicated for Q = 0.0015 CFM/SF**

Pipe Diameter (Inches)	Minimum Time (Min:Sec)	Length for Min. Time (Feet)	Time for increased Length (Sec)	Specification Time for Length (L) Shown (Min:Sec)								
				100 Ft.	150 Ft.	200 Ft.	250 Ft.	300 Ft.	350 Ft.	400 Ft.	450 Ft.	
4	1:53	597	0.190 L	1:53	1:53	1:53	1:53	1:53	1:53	1:53	1:53	1:53
6	2:50	398	0.427 L	2:50	2:50	2:50	2:50	2:50	2:50	2:50	2:51	3:12
8	3:47	298	0.760 L	3:47	3:47	3:47	3:47	3:47	3:48	4:26	5:04	5:42
10	4:43	239	1.187 L	4:43	4:43	4:43	4:57	5:56	6:55	7:54	8:54	8:54
12	5:40	199	1.709 L	5:40	5:40	5:42	7:08	8:33	9:58	11:24	12:50	12:50
15	7:05	159	2.671 L	7:05	7:05	8:54	11:08	13:21	15:35	17:48	20:02	20:02
18	8:30	133	3.846 L	8:30	9:37	12:49	16:01	19:14	22:26	25:38	28:51	28:51
21	9:55	114	5.235 L	9:55	13:05	17:27	21:49	28:11	30:32	34:54	39:16	39:16
24	11:20	99	6.837 L	11:24	17:57	22:48	28:30	34:11	39:53	45:35	51:17	51:17
*27	12:45	88	8.653 L	14:25	21:38	28:51	36:04	43:18	50:30	57:42	64:54	64:54
*30	14:10	80	10.683 L	17:48	26:43	35:37	44:31	53:25	62:19	71:13	80:07	80:07
*33	15:35	72	12.926 L	21:33	32:19	43:56	53:52	64:38	75:24	86:10	96:57	96:57
*36	17:00	66	15.384 L	25:39	38:28	51:17	64:06	76:55	89:44	102:34	115:23	115:23

\*NOTE - Consult with pipe and appurtenance manufacturer for maximum test pressure for pipe size greater than twenty four inches (24") in diameter.

**FORMULA**

The formula below calculates the specified minimum time required for a **1.00 psig pressure drop** from a starting pressure of 3.5 psig to a final pressure of 2.5 psig using a leakage rate of 0.0015 cubic feet/minute/square foot of internal surface.

Calculate all test times by the following formula:

$$T = 0.085 DK/Q$$

where:

T = shortest time allowed for the **air pressure to drop 1.0 psig**, sec.

K = 0.000419 DL but not less than 1.0,

Q = leak rate = 0.0015 CFM/SF,

D = measured average inside diameter of sewer pipe, in., and

L = length of test section, ft.

**E2 Hydrostatic Test Method**

*E2a Gravity Sewers*

After bulkheading the test section, the pipe shall be subjected to a hydrostatic pressure produced by a head of water at a depth of three feet (3') above the invert elevation of the sewer at the upstream manhole of the test section. In areas where ground water exists, this head of water shall be three feet (3') above the existing water table.

The water head shall be maintained for a period of one (1) hour during which time it will be presumed that full absorption of the pipe body has taken place, and thereafter for an extended period of one (1) hour the water head shall be maintained as the test period. During the test period, the measured water loss within the test section, including service stubs, shall not exceed an infiltration / exfiltration rate of thirty five (35) gallons / inch diameter / mile / day.

If measurements indicate exfiltration within a test action section is not greater than the allowable maximum, the section will be accepted as passing the test.

### *E2b Pressure Sewers*

For sewers designated as pressure pipe sewers, the sewer shall be subjected to hydrostatic testing under 2611.3G Hydrostatic Testing of Watermains, except the hydrostatic testing pressure shall be two (2) times the maximum design operating pressure, but not less than one hundred (100) psig and the duration of the test shall be one hour.

### **E3 Test Failure and Remedy**

In the event of test failure on any test section, testing shall be continued until all leakage has been detected and corrected to meet the requirements. All repair work shall be subject to approval of the Engineer. Introduction of sealant substances by means of the test water will not be permitted.

Unsatisfactory repairs or test results may result in an order to remove and replace pipe as the Engineer considers necessary for test conformance. All repair and replacement work shall be at the Contractor's expense.

### **F Deflection Test**

Deflection tests shall be performed on all plastic gravity sewer pipes. The test shall be conducted after the sewer trench has been backfilled to the desired finished grade and has been in place for thirty (30) days.

The deflection test shall be performed by pulling a rigid ball or nine-point mandrel in accordance with MnDOT 2503.3 C.4. Direct measurement of the pipe diameter to determine deflection is not allowed. The ball or mandrel shall have a minimum diameter equal to ninety five percent (95%) of the actual inside diameter of the pipe. The maximum allowable deflection shall not exceed five percent (5%) of the pipe's internal diameter. The line will be considered acceptable if the mandrel can progress through the line without binding. The time of the test, method of testing, and the equipment to be used for the test shall be subject to the approval of the Engineer.

All testing shall be performed by the Contractor at his expense without any direct compensation being made therefore, and he shall furnish all necessary equipment and materials required.

### **F1 Test Failure and Remedy**

In the event of test failure on any test section, the section shall be replaced, with all repair work subject to approval of the Engineer. The replaced section shall be retested for leakage and deflection in conformance with the specifications contained herein. All repairs, replacement, and retesting shall be at the Contractor's expense.

## **G     Televising**

Sewer line televising may be required by the Engineer, at the cost of the Contractor, if visual inspection, leakage testing, or deflection testing indicate the sewer has not been constructed in accordance with these specifications and the requirements of the Plans, Specifications, and Special Provisions.

### **2621.4 METHOD OF MEASUREMENT**

All items will be measured separately according to design designation as indicated in the Pay Item name and as may be detailed and defined in the Plans, Specifications, or Special Provisions.

Complete-in-place items shall include all component parts thereof as described or required to complete the unit, but excluding any excesses covered by separate Pay Items. Linear measurement of piping will include the running length of any special fittings (tees, wyes, elbows, gates, etc.) installed within the line of measure between specified terminal points.

#### **A     Sewer Pipe**

Sewer pipe of each design designation will be measured by length in linear feet along the line of pipe. Terminal points of measurement will be the pipe end at free outlets; the point of connection with in-place pipe; the center of manholes or catch basins; the point of centerline intersections at branch fittings; or the point of juncture with other appurtenances or units as defined.

Separation of quantities according to "depth zone classification", when so designated in the Pay Item, will be determined by depth of pipe invert below the ground surface profile.

#### **B     Manholes**

Manholes of each design designation will be measured by number of each constructed complete-in-place, including the base and castings as required, but excluding any excess depth greater than eight feet (8') measured from top of manhole cover to invert elevation of lowest pipe.

Excess manhole depth of each design designation will be measured by the linear foot difference in depth between the eight feet (8') allowed as standard and the actual increased depth as constructed.

#### **C     Catch Basins**

Catch basins of each design designation will be measured by number of each constructed complete-in-place, including the base and castings as required, but excluding any excess depth greater than five feet (5') measured from top of grate (low point) to invert elevation of lowest outlet pipe.

Excess catch basin depth of each design designation will be measured by the linear foot difference in depth between the five feet (5') allowed as standard and the actual increased depth as constructed.

**D Outside Drop Connection**

Outside drop connections of each design will be measured by linear foot constructed complete-in-place, and shall include granular encasement, fittings, any special piping required, including coring holes and watertight boots for existing manholes for the drop connection. Measurement shall be made vertically from the invert of the lower outside drop invert to the upper outside drop invert.

**E Service Connection**

Service Connections of each design will be measured by number of each constructed complete-in-place as specified.

**F Service Pipe**

Service pipe of each design will be measured separately by length in linear feet, horizontally along the line of installation, between the service end and the point of juncture with the main pipe connection fitting.

**G Special Pipe Fittings**

Special pipe fittings (wyes, tees, bends, etc.) of each design designation will be measured by number of each installed complete-in-place as specified, but excluding any such fittings required to be installed as a component part of any other Work Unit.

**H Appurtenant Items**

Appurtenant items such as aprons, trash guards, gates and other prefabricated units or assemblies as identified by Pay Item name will be measured separately by number of each installed complete-in-place as specified.

**2621.5 BASIS OF PAYMENT**

Payment for sewer pipe and service pipe items at the Contract prices per linear foot of pipe of each design shall be compensation in full for all costs of providing a complete-in-place pipeline, including excavation, foundation preparation, backfilling, leakage testing, restoration of surface improvements, disposal of surplus or waste materials, final cleanup, and such other work as may be specified, but excluding the construction of other structures or special sections and the placement of special fittings, appurtenances or materials specifically designated for payment under other Contract Items.



Payment for manhole, catch basin, outside drop connection, service connection, and other structures as specified, at the Contract prices per structure, shall be compensation in full for all costs of constructing each unit complete-in-place as specified, including all required castings, special fittings, base or encasement, and appurtenant materials as specified for the complete structure or section, but excluding such additional work as may be designated for payment under other Contract Items.

Where the specified standard manhole, catch basin, or outside drop connection depths are exceeded, the excess depth of each design will be paid for separately as linear footage items and payment at the Contract prices therefor shall be compensation in full for all costs of providing the extra depth.

Special pipe fittings such as wyes, tees and bends will be paid for as separate Contract Items to the extent they are required to be installed in the sewer pipe and service pipe lines and not as a component part of a complete-in-place structure (outside drop connections, service connections, etc.)

Appurtenant items such as aprons, trash guards, drainage gates, and other prefabricated units or assemblies and specials as designated will be paid for as separate Contract Items to the extent they are not included as a component part of any complete-in-place structure.

## **SECTION 2631 CIPPS – STANDARD SPECIFICATIONS FOR SEWER PIPE REHABILITATION WITH CURED IN-PLACE PIPE SYSTEMS (CIPPS)**

### **2631.1 CIPPS DESCRIPTION**

#### **A General**

This work shall consist of the rehabilitation of pipelines and conduits by the installation of a resin-impregnated flexible tube Cured-In-Place Pipe System (CIPPS). The rehabilitation of pipelines shall be constructed by the installation of a resin-impregnated flexible tube which, when cured, shall be continuous and tight-fitting throughout the entire length of the original pipe. The CIPP shall extend the full length of the original pipe and provide a structurally sound, joint less and watertight new pipe within the existing pipe. The Contractor is responsible for proper, accurate and complete installation of the CIPP using the system selected by the Contractor.

Neither the CIPP system, nor its installation, shall cause adverse effects to any downstream facilities. The use of the product shall not result in the formation or production of any detrimental compounds or by-products that may affect downstream structures, pumps, pipe, equipment and wastewater treatment facilities. The Contractor shall notify the Engineer and identify any by-products produced as a result of the installation operations, test and monitor the levels, and comply with any and all local waste discharge requirements. The Contractor shall cleanup, restore existing surface conditions and structures, and repair any of the CIPP system determined to be defective. The Contractor shall conduct installation operations and schedule cleanup in a manner to cause the least possible obstruction and inconvenience to traffic, pedestrians, businesses, and residents.

The use of the term "Plans, Specifications, and Special Provisions" within this specification shall be construed to mean those documents which compliment, modify, or clarify these specifications and are an enforceable component of the Contract Documents.

All references to MnDOT Specifications shall mean the latest published edition of the Minnesota Department of Transportation "Standard Specifications for Construction", and all supplements and amendments thereto, published prior to the date of advertisement for bids.

All references to other Specifications of AASHTO, ASTM, ANSI, AWWA, etc. shall mean the latest published edition available on the date of advertisement for bids.

The following specifications have been referenced in this Specification:

ASTM F1216 Standard Practice for Rehabilitation of Existing Pipelines and Conduits by the Inversion and Curing of a Resin-Impregnated Tube  
ASTM F1743 Standard Practice for Rehabilitation of Existing Pipelines and Conduits by Pulled-in-Place Installation of Cured-in-Place Thermosetting Resin Pipe (CIPP)  
ASTM D543 Standard Practice for Evaluating the Resistance of Plastics to Chemical Reagents  
ASTM D638 Standard Test Method for Tensile Properties of Plastics  
ASTM D790 Standard Test Methods for Flexural Properties of Un-reinforced and Reinforced Plastics and Electrical Insulating Materials  
ASTM D792 Standard Test Methods for Density and Specific Gravity of Plastics by displacement.

ASTM F2019 Standard Practice for Rehabilitation of Existing Pipelines and Conduits by the Pulled in Place Installation of Glass Reinforced Plastic (GRP) Cured-in- Place Thermosetting Resin Pipe (CIPP)

ASTM D2122 Standard Test Method for Determining Dimensions of Thermoplastic Pipe and Fittings

ASTM D2990 Standard Test Methods for Tensile, Compressive, and Flexural Creep and Creep-Rupture of Plastics

ASTM D5813 Standard Specification for Cured-in Place Thermosetting Resin Sewer Piping Systems

## **B Qualifications**

The Contractor shall be responsible for all aspects of the design of the liner pipe. The Contractor shall guarantee that the installed liner is capable of sustaining outside loads, resist chemical attack that normally occurs in sanitary and storm sewer systems, and will maintain hydraulic characteristics over a fifty (50) year design life.

Unless provided otherwise in the plans or Special Provisions, the existing sewer pipe shall be considered to be in a fully deteriorated condition, is not structurally sound, and cannot support soil and live loads. The cured-in-place pipe shall be designed to support hydraulic, soil, and live loads.

The sewer products are intended to have a fifty (50) year or greater design life, and in order to minimize the Owner's risk, only proven products with substantial successful long term track records will be approved.

### **B1 Manufactured Products and Installation**

Contractors must meet all of the following criteria:

- a. For a Product to be considered acceptable, a minimum of 100,000 linear feet or two hundred fifty (250) manhole-to-manhole line sections of successful wastewater collection system installations in the U.S. must be documented to the satisfaction of the Engineer. In addition, at least 50,000 linear feet of the product shall have been in successful service within the State for a minimum of five (5) years.
- b. The Contractor's personnel must satisfy all insurance, financial, and bonding requirements of the Owner, and must have had at least 5 (five) years active experience in the commercial installation of the product bid. In addition, the Contractor's personnel must have successfully installed at least 100,000 feet of the same product bid. The Field Supervisor/Foreman shall have a minimum five (5) years as a foreman/superintendent for a cured-in-place lining crew (installing actual product included with this bid/proposal), and a minimum of 100,000 lineal feet of cured-in-place lining, diameters up to and including twenty-four inches (24") installed under his/her supervision. Such experience shall include the actual product, by trade name, Contractor proposes to install. Acceptable documentation of these minimum installations must be submitted to the Engineer.

- c. Sewer rehabilitation products submitted for approval must provide Third Party Test Results supporting the long-term performance and structural strength of the product and such data shall be satisfactory to the Engineer. Test samples shall be prepared so as to simulate installation methods and trauma of the product. No product will be approved without independent third party testing verification.

## **2631.2 CIPPS MATERIALS**

### **A General**

All materials required for this work shall be new material conforming to requirements of the referenced specifications for the class, kind, type, size, grade, and other details indicated in the Contract. Unless otherwise indicated, all required materials shall be furnished by the Contractor. If any options are provided for, as to type, grade, or design of the material, the choice shall be limited as may be stipulated in the Plans, Specifications, or Special Provisions.

All manufactured products shall conform in detail to such standard design drawings as may be referenced or furnished in the Plans. Otherwise, the Owner may require advance approval of material suppliers, product design, or other unspecified details as it deems desirable for maintaining adopted standards.

All materials shipped to the project site shall be accompanied by test reports certifying that the material conforms to the ASTM standards listed herein. Materials shall be shipped, stored, and handled in a manner consistent with written recommendations of the CIPP manufacturer to avoid damage. Damage includes but is not limited to, gouging, abrasion, flattening, cutting, puncturing, and ultra-violet (UV) degradation. All damaged materials shall be promptly removed from the project site at no cost to the Owner. On site material storage locations shall be approved by the Engineer.

### **A1 CIPPS Fabric Tube**

The CIPPS fabric "Tube" shall consist of one or more layers of absorbent non-woven felt fabric, felt/fiberglass or fiberglass and meet the requirements of ASTM F 1216, ASTM F 1743, ASTM D5813 & ASTM F2019. The fabric Tube shall be capable of absorbing and carrying resins, manufactured to withstand installation pressures and curing temperatures, have sufficient strength to bridge missing pipe segments, and stretch to fit irregular pipe sections.

The fabric Tubes shall have a uniform thickness that when compressed at installation pressures will equal the specified nominal tube thickness.

The wet-out fabric tube shall have a uniform thickness and excess resin distribution that when compressed at installation pressures will meet or exceed the design thickness after cure.

The fabric tube shall be manufactured to a size and length that when installed will tightly fit the internal circumference and length of the original pipe. Allowance shall be made for circumferential stretching during installation. The tube shall be properly sized to the diameter of the existing pipe and the length to be rehabilitated and be able to stretch to fit irregular pipe sections and negotiate bends. The Contractor shall determine the minimum tube length necessary to effectively span the designated run between manholes. The Contractor shall verify the lengths in the field prior to ordering and prior to impregnation of the tube with resin, to ensure that the tube will have sufficient length to extend the entire length of the run. The

Contractor shall also measure the inside diameter of the existing pipelines in the field prior to ordering liner so that the liner can be installed in a tight-fitted condition. Overlapped layers of felt in longitudinal seams that cause lumps in the final product shall not be allowed.

The minimum length of the fabric tube shall be that deemed necessary by the installer to effectively span the distance from the starting manhole to the terminating manhole or access point, plus that amount required to run-in and run-out for the installation process.

The outside and/or inside layer of the fabric tube (before inversion/pull-in, as applicable) shall be coated with an impermeable, flexible membrane that will contain the resin and facilitate, if applicable, vacuum impregnation and monitoring of the resin saturation during the resin impregnation (wet-out) procedure.

No material shall be included in the fabric tube that may cause de-lamination in the cured CIPP. No dry or unsaturated layers shall be acceptable upon visual inspection as evident by color contrast between the felt fabric and the activated resin containing a colorant. The tube shall be homogeneous across the entire wall thickness containing no intermediate or encapsulated elastomeric layers. No materials shall be included in the tube that is subject to delamination in the CIPPS.

The wall color of the interior pipe surface of CIPP after installation shall be a light reflective color so that a clear detailed examination with closed circuit television inspection equipment may be made. The hue of the color shall be dark enough to distinguish a contrast between the fully resin saturated felt fabric and dry or resin lean areas.

Seams in the fabric tube, if applicable, shall meet the requirements of ASTM D5813. The outside of the fabric tube shall be marked every five feet (5') with the name of the manufacturer or CIPP system, manufacturing lot and production footage.

The nominal fabric tube wall thickness shall be constructed to the nearest 0.5 mm increment, rounded up from the design thickness for that section of installed CIPP. Wall thickness transitions, in 0.5 mm increments or greater as appropriate, may be fabricated into the fabric tube between installation entrance and exit access points. The quantity of resin used in the impregnation shall be sufficient to fill all of the felt voids for the nominal felt thickness.

The resin shall be a corrosion resistant polyester or vinyl ester resin and catalyst system that when properly cured within the tube composite meets the requirements of ASTM F1216, ASTM F1743 or F2019, the physical properties herein, and those, which are to be utilized in the design of the CIPP for this application. The resin shall produce CIPP which will comply with or exceed the structural and chemical resistance requirements of this specification.

## **A2 CIPPS Structural Requirements**

The physical properties and characteristics of the finished liner will vary considerably, depending on the types and mixing proportions of the materials used, and the degree of cure executed. It shall be the responsibility of the Contractor to control these variables and to provide a CIPP system which meets or exceeds the minimum properties specified herein:

- (1) The CIPP shall be designed as per ASTM standards. The CIPP design shall assume no bonding to the original pipe wall.
- (2) The design engineer shall set the long term (fifty (50) year extrapolated) Creep Retention Factor at thirty three percent (33%) of the initial design flexural modulus as determined by ASTM D-790 test method. This value shall be used unless the Contractor submits long term test data (ASTM D2990) to substantiate a higher retention factor.
- (3) The layers of the cured CIPP shall be uniformly bonded. It shall not be possible to separate any two (2) layers with a probe or point of a knife blade so that the layers separate cleanly or the probe or knife blade moves freely between the layers. If separation of the layers occurs during testing of field samples, new samples will be cut from the work. Any reoccurrence may cause rejection of the work.

Minimum Physical Properties: The cured pipe material (CIPP) shall, at a minimum, meet or exceed the structural properties, as listed in the table below.

Property	Test Method	Cured Composite Per ASTM F1216	Cured Composite Per Design
Flexural Modulus of Elasticity (Short Term)	ASTM D790	250,000 Psi	Contractor Value
Flexural Strength (Short Term)	ASTM D790	4,500 Psi	Contractor Value

The required structural CIPP wall thickness shall be based as a minimum, on the physical properties listed above and in accordance with the Design Equations in the appendix of ASTM F 1216, and the following design parameters:

Design Safety Factor	2.0 (1.5 For Pipes 36" Or Larger)
Creep Retention Factor	33%
Ovality	2% Or As Measured By Field Inspection
Constrained Soil Modulus	Per AASHTO LRFD Section 12 And AWWA Manual M45
Groundwater Depth	As Specified Or Indicated On The Plans
Soil Depth (Above The Crown)	As Specified Or Indicated On The Plans
Live Load	H20 Highway
Soil Load (Assumed)	120 Lb/Cu. Ft.
Minimum Service Life	50 Years

The Contractor shall submit, prior to installation of the lining materials, certification of compliance with these specifications and/or the requirements of the pre-approved CIPP system. Certified material test results shall be included that confirm that all materials conform to these specifications. Materials not complying with these requirements will be rejected.

CIPP Short-Liners or segmental liners shall be of the same materials and meet the structural requirements of the full CIPP Tube liner.

### **A3 Material Testing Requirements**

- (1) Chemical Resistance - The CIPP shall meet the chemical resistance requirements of ASTM F1216, Appendix X2. CIPP samples for testing shall be of tube and resin system similar to that proposed for actual construction. It is required that CIPP samples with and without plastic coating meet these chemical testing requirements.
- (2) Hydraulic Capacity - Overall, the hydraulic profile shall be maintained as large as possible. The CIPP shall have a minimum of the full flow capacity of the original pipe before rehabilitation. Calculated capacities may be derived using a commonly accepted roughness coefficient for the existing pipe material taking into consideration its age and condition.
- (3) CIPP Field Samples - When requested by the Owner, the Contractor shall submit test results from field installations in the USA of the same resin system and tube materials as proposed for the actual installation. These test results must verify that the CIPP physical properties specified in above have been achieved in previous field applications. Samples for this project shall be made and tested as described herein.

### **2631.3 CIPPS CONSTRUCTION REQUIREMENTS**

The Contractor shall clean the interior of the existing host pipe prior to installation of the CIPP liner. All debris and obstructions that will affect the installation and the final CIPP product shall be removed and disposed of. The CIPP liner shall be constructed of materials and methods, that when installed, shall provide a joint less and continuous structurally sound liner able to withstand all imposed static and dynamic loads on a long-term basis.

#### **A Installation of CIPPS**

##### **A1 Access**

It will be the responsibility of the Owner to locate and designate all manhole access points open and accessible for the work, and provide rights of access to these points. If a street must be closed to traffic because of the orientation of the sewer, the Contractor shall institute the actions necessary to do this for the mutually agreed time period. Traffic Control shall be the responsibility of the Contractor and shall conform to the latest revision of the MMUTCD and other provisions of this specification herein. The Contractor shall keep the roadway open to traffic at all times unless given prior approval by the Engineer.

##### **A2 Water Usage**

Water is available from the City at designated locations for cleaning, inversion, and other work items requiring water. Use of an approved double check backflow assembly shall be required. The Contractor shall provide his own approved assembly. The Contractor may use City water but shall inform the Public Works Department of such use and obtain a meter for documenting water usage. No fees will be charged for water.

### **A3 Cleaning of Sewer Lines**

The Contractor shall remove all internal debris from the pipe line that will interfere with the installation and the final product delivery of the CIPP as required in these specifications. Solid debris and deposits shall be removed from the system and disposed of properly by the Contractor. Moving material from manhole section to manhole section shall not be allowed. As applicable the contractor shall either plug or install a flow bypass pumping system to properly clean the pipe lines. The Contractor shall ensure that no debris is transferred downstream during cleaning operations. The Contractor shall use a vacuum vehicle or similar means to remove debris during cleaning operations. Precaution shall be taken, by the Contractor in the use of cleaning equipment to avoid damage to the existing pipe. The repair of any damage, caused by the cleaning equipment, shall be the responsibility of the Contractor. Disposal of the cleaning debris shall be in accordance with local, State and Federal Law and shall be incidental to the CIPPS.

### **A4 Bypassing Wastewater**

The Contractor shall provide a by-pass for the flow of existing mainline and service connection effluent around the section or sections of pipe designated for CIPP installation. Installation of the liner shall not begin until the Contractor has installed a sewage by-pass system and all pumping facilities have been installed and tested under full operating conditions including the bypass of mainline and side sewer flows. Once the lining process has begun, existing sewage flows shall be maintained, until the resin/felt tube composite is fully cured, cooled down, fully televised and the CIPP ends finished. The Contractor shall coordinate sewer bypass and flow interruptions with the Engineer at least fourteen (14) days in advance and with the property owners and businesses at least three (3) business days in advance. The pump and bypass lines shall be of adequate capacity and size to handle peak flows. The Contractor shall submit a detail of the bypass plan and design to the Engineer prior to proceeding with any CIPP installation. Compensation for by-pass pumping and all associated plans and approvals shall be included in the price bid for CIPPS Installation.

### **A5 Inspection of Pipelines**

Inspection of pipelines shall be performed by experienced personnel trained in locating breaks, obstacles, and service connections by closed circuit television. The interior of the pipeline shall be carefully inspected to determine the location of any conditions which may prevent proper installation of the CIPPS into the pipelines and it shall be noted so that these conditions can be corrected. A video and suitable log shall be kept for later reference by the Owner. The Owner has copies of a video inspection of the sewers to be relined, and these are available for prospective bidders. However, since the deterioration of sewer is an ongoing process, and roots, solids, and deposits can accumulate over time, the Contractor shall base the design of the liner on inspections made immediately prior to installation.



## **A6 Line Obstructions**

It shall be the responsibility of the Contractor to clear the line of obstructions such as solids and roots that will prevent the insertion of CIPP. If pre-installation inspection reveals an obstruction such as a protruding service connection, dropped joint, or a collapse that will prevent the inversion process, that was not evident on the pre-bid video and it cannot be removed by conventional sewer cleaning equipment, if directed by the Owner, the Contractor shall make a point repair excavation to uncover and remove or repair the obstruction. Such excavation shall be approved in writing by the Owner's representative prior to the commencement of the work and shall be considered as a separate pay item.

## **A7 Public Notification**

The Contractor shall make every effort to maintain service usage throughout the duration of the project. In the event that a service will be out of service, the maximum amount of time of no service shall be eight (8) hours for any property served by the sewer. A public notification program shall be implemented, and shall as a minimum, require the Contractor to be responsible for contacting each home or business connected to the sanitary sewer and informing them of the work to be conducted, and when the sewer will be off-line. The Contractor shall also provide the following:

- (1) Written notice to be delivered to each home or business the day prior to the beginning of work being conducted on the section, and a local telephone number of the Contractor they can call to discuss the project or any problem which could arise.
- (2) Personal contact with any home or business, which cannot be reconnected within the time stated in the written notice.
- (3) Notification shall include advisory statements to the resident that:
  - a. To minimize odor problems during the installation of CIPP, residents should be advised to ensure that their sewer traps are in a proper state of repair. In cases of damaged, dry, or non-existent traps, the areas or rooms where floor drains or access to traps are located should be ventilated, if possible, by leaving doors or windows open to the outside during the CIPP installation process.

The Contractor shall be responsible for confirming the locations of all branch service connections prior to installing and curing the CIPP.

## **A8 Liner Installation**

CIPP installation shall be in accordance with the applicable ASTM standards with the following modifications:

- (1) The wet-out tube shall be positioned in the pipeline using the method specified by the manufacturer. Care should be exercised not to damage the tube as a result of installation. The tube should be pulled-in or inverted through an existing manhole or approved access point and fully extend to the next designated manhole or termination point. If pulled into place, a power winch should be utilized, and care should be exercised not to damage the tube as a result of pull-in friction.

- (2) Prior to installation and as recommended by the manufacturer remote temperature gauges or sensors shall be placed inside the host pipe to monitor the temperatures during the cure cycle. Liner and/or host pipe interface temperature shall be monitored and logged during curing of the liner.
- (3) Curing shall be accomplished by utilizing the appropriate medium in accordance with the manufacturer's recommended cure schedule. The curing source or in and output temperatures shall be monitored and logged during the cure cycles. The manufacturer's recommended cure schedule shall be used for each line segment installed, and the liner wall thickness and the existing ground conditions with regard to temperature, moisture level, and thermal conductivity of soil, per ASTM as applicable, shall be taken into account by the Contractor.
- (4) The Contractor shall remove protruding taps to the inside wall of the pipe. In no case shall the pipe be less than ninety five percent (95%) open to flow.

### **A9 Resin Impregnation**

The quantity of resin used for tube impregnation shall be sufficient to fill the volume of air voids in the tube with additional allowances for polymerization shrinkage and the loss of resin through cracks and irregularities in the original pipe wall. A vacuum impregnation process shall be used. To insure a through wet-out, the point of vacuum shall be no further than twenty-five feet (25') from the point of initial resin introductions. After vacuum in the tube is established, the vacuum points shall be no further than seventy-five feet (75') from the leading edge of the resin. The leading edge of the resin slug shall be as near to perpendicular to the longitudinal axis of the tube as possible. A roller system shall be used to uniformly distribute tie resin throughout the tube. If the Installer proposes an alternate method of resin impregnation, the method must produce the same results and the method approved by the Engineer.

### **A10 Cool Down**

The Contractor shall cool the CIPP in accordance with the manufacturer's recommendations. Temperatures and curing data shall be monitored and recorded, by the Contractor, throughout the installation process to ensure that each phase of the process is achieved as approved in accordance with the CIPP System manufacturer's recommendations.

Proper curing and handling of CIPP systems shall be done using the following guidelines for discharge of by-products:

Water Curing Method:

#### **Sanitary Sewers**

- (1) Release process water to the sewer after per industry standards during/after cool-down.

#### **Storm Sewers and Culverts**

- (1) Based upon receiving waterway's assimilative capacity
  - a. Discharge water when cooled to ambient air temperature
  - b. Discharge water once styrene concentration is confirmed to be at or below 25ppm; or,
  - c. Transport process water to nearest wastewater treatment facility

## Steam Curing Method:

### Sanitary Sewers

- (1) Release condensate water directly to receiving sewer while processing

### Storm Sewers and Culverts

- (1) Based upon receiving waterway's assimilative capacity
  - a. Detain condensate in a lined holding pond until it cools to ambient
  - b. Discharge water once styrene concentration is confirmed to be less than 25ppm; or
  - c. Retrieve condensate by pumping it into the steam generation truck's reservoir; or
  - d. Transport condensate to nearest wastewater treatment facility.

## **A11 Finishing Operations**

The installed CIPP shall be continuous over the entire length of a sewer line section and be free from visual defects such as foreign inclusions, dry spots, pinholes, major wrinkles and delamination. The lining shall be impervious and free of any leakage from the pipe to the surrounding ground or from the ground to inside the lined pipe. Any defect, which will or could affect the structural integrity or strength of the linings, shall be repaired at the Contractor's expense. The beginning and end of the CIPP shall be sealed to the existing host pipe. The sealing material shall be compatible with the pipe end and shall provide a watertight seal. If any of the service connections leak water between the host pipe and the installed liner, the connection mainline interface shall be sealed to provide a watertight connection. If the wall of the CIPP leaks, it shall be repaired or removed and replaced with a watertight pipe as recommended by the manufacture of the CIPP system.

At all points where the liner pipe has been exposed (such as service connection fittings, or other points where the old pipe must be removed), the liner pipe and fittings shall be encased in cement-stabilized sand or other high density material as specified by the Engineer to prevent deflection due to difference in subsidence. After the encasement material is in place and accepted by the Engineer, backfill is placed and compacted to require finish grade in accordance with the specifications. Particular care should be taken to ensure compaction of earth beneath the lateral/service pipe in order to reduce subsidence and resultant bending at the lateral connection at the sewer main.

## **A12 Manhole Connections**

A seal, consisting of a resin mixture or hydrophilic seal compatible with the installed CIPP shall be applied at manhole walls in accordance with the CIPP System manufacturer's recommendations.

### **A13 Reconnections of Existing Services**

Services shall be identified by the Contractor prior to lining work. After the pipe has been reconstructed and tested, the service connections shall be reconnected. It is the Contractor's responsibility to make sure that all service connections are reconnected, unless otherwise directed by the Engineer. A CCTV camera and remote cutting tool shall be used for internal reconnections. The machined opening shall be at least ninety five percent (95%) of the service connection opening and the bottom of both openings must match. The opening shall not be more than one hundred percent (100%) of the service connection opening.

The edges of the opening shall not have pipe fragments or liner fragments, which may obstruct flow or snag debris. In the event that service reinstatements result in openings that are greater than one hundred percent (100%) of the service connection opening, the Contractor shall install a CIPP type repair, sufficiently in size to completely cover the over-cut service connection. No additional compensation will be paid for the repair of over-cut service connections. Discs of pipe material resulting from service tap cutting shall be collected at the next manhole downstream of the pipe rehabilitation operation prior to leaving the site. Discs shall not be allowed to pass through the system.

### **A14 CIPP Short-Liner**

The CIPP short-liner shall meet the requirements of the full length CIPP liner and the following:

- (1) The Short-Liner shall be inserted into the existing sewer line with a power winch and steel cable attached to the end of the liner by use of an appropriate pulling head. Length of the liner to be inserted at any one time shall be governed by the length of the section in need of repair or the maximum length of the installation equipment considering the size and condition of the sewer.
- (2) A mobile installation unit shall be brought to the site ready to process the liner. The installation unit shall contain heat generating equipment, CCTV facility and other auxiliary miscellaneous equipment necessary for controlling processing of the Short-Liner pipe. The equipment shall be positioned next to the point of entry with minimum obstruction to the other side activities and shall be operated by trained personnel only.
- (3) The pressure shall be increased to compensate for the heating-cooling transition and it shall be maintained until the temperature at the lowest critical point is 100° F (38° C). This shall constitute completion of the Short-Liner pipe processing. The pipe within the pipe shall be tight fitting and adapted to the existing sewer pipe.

## **B TESTING AND INSPECTION**

### **B1 Testing**

CIPP samples shall be prepared and tested in accordance with ASTM F1216, Section 8.1, using either method proposed. Leakage testing of the CIPP shall be accomplished during cure while under a positive head. CIPP products in which the pipe wall is cured while not in direct contact with the pressurizing fluid (e.g., a removable bladder) must be tested by an alternative method approved by the Engineer.

### **B2 Inspection**

Visual inspection of the CIPP shall be in accordance with ASTM F1216, Section 8.4. The relined pipe shall be continuous without joints through the entire pipe length. The liner shall be free of all visible defects except those resulting from pre-lined conditions which the Contractor has noted prior to lining. There shall be no pits, pinholes, cracks, or crazing, and the surface shall be smooth and free of waviness throughout the pipe. Any defects shall be repaired by the Contractor with no expense to the Owner. Where leakage is observed through the wall of the pipe, the contractor shall institute additional testing including but not limited to air testing, localized testing and any other testing that will verify the leak proof integrity of the installed CIPP to the satisfaction of the Owner.

### **B3 Televising**

Prior to final acceptance of any sanitary sewer relining including short-liners, the Contractor shall inspect by means of remote closed circuit television equipment the entire segment of sanitary sewer, manhole-to manhole. Sewer shall be cleaned prior to inspection. A video of the inspection shall be furnished to the City. The following conditions shall apply to the sewer acceptance TV inspection:

- (1) The video shall be in a format to be decided by the Owner, that creates high quality picture and sound and shall be recorded in color.
- (2) The TV camera shall be pulled through the sewer at a maximum rate of thirty-five feet (35') per minute.
- (3) The camera shall be pulled downstream in all cases.
- (4) The lens of the camera shall be cleaned at each manhole or when directed by the Owner.
- (5) The recording shall have an on-screen display showing the following:
  - a. Upstream and downstream manhole numbers
  - b. Footage from the upstream manhole
  - c. Inspection date
- (6) Sewers shall not be televised within forty-eight (48) hours of a rainfall event greater than one half inch ( $\frac{1}{2}$ ").

#### **2631.4 CIPPS METHOD OF MEASUREMENT**

Measurement for CIPP Lining shall be on a linear foot basis, to the nearest whole foot, measured from center of manhole to center of manhole.

#### **2631.5 CIPPS BASIS OF PAYMENT**

The proposal form shall cover all work shown on the contract drawings, specifications, and Special Provisions. All costs associated with the work including furnishing of all materials, providing all construction and equipment, and performing all necessary labor, coordination, supervision, and management to fully complete the work, shall be included in the unit or lump sum prices quoted in the proposal form. This work shall include restoration of all surfaces to their original condition or better. Reconnection of all existing services shall be considered incidental to the CIPPS. All work not specifically set forth as a pay item in the proposal form shall be considered a subsidiary obligation of the Contractor and all costs in connection therewith shall be included in the amounts and prices submitted in the proposal form.

The following methods of measurement for payment will be used to derive the quantities installed:

##### **(1) Site Protection and Restoration**

- a. No separate payment will be made for protection and restoration of roadway surfaces, curb and gutter, landscaping, and other site features unless otherwise specified.

##### **(2) Spot Repair to existing pipe**

- a. Bid items have been provided in the proposal for removal and replacement of pipe as Spot or Point Repairs. No additional compensation will be granted for repairs.

##### **(3) Cured-in-Place Pipe System (CIPPS)**

- a. Payment shall be made at the unit price as listed on the proposal. All work related to the cleaning, installation and acceptance of the system as a whole shall be considered incidental to CIPPS installation.
- b. Payment for re-instatement of services shall be at the unit price listed on the proposal per each service, and shall be compensation in full for all materials, labor, equipment, and maintenance necessary to complete the work as required by the plans or required by the Engineer.
- c. Payment for Short-Liner installations shall be made at the unit price listed on the proposal and shall be compensation in full for all materials, labor, equipment, and maintenance necessary to complete the work as required by the plans or required by the Engineer.

## **SECTION 2641 – STANDARD SPECIFICATIONS FOR PIPELINE REHABILITATION BY PIPE BURSTING**

### **2641.1 DESCRIPTION**

#### **A General**

All references to MnDOT Specifications shall mean the latest published edition of the Minnesota Department of Transportation “Standard Specifications for Construction”, and all supplements and amendments thereto, published prior to the date of advertisement for bids.

This specification shall cover the rehabilitation of existing gravity and pressure utility pipelines using pipe bursting methods. Pipe bursting is a process by which the bursting unit fractures the existing pipe while simultaneously installing a new pipe of the same size or larger size pipe in the place of the existing pipe. Existing lateral and service connections are disconnected prior to mainline pipe bursting to reduce lateral pipe/service pipe damage, then reconnected after testing and disinfection of the new pipe as applicable is approved, television inspection of the new pipe is performed, and the installation is completed in accordance with the contract documents.

### **2641.2 QUALIFICATIONS**

The Contractor shall be certified by the particular Pipe Bursting System Manufacturer as a fully trained installer of the pipe bursting system. The Contractor shall provide certifications of training and proficiency in the use of the equipment. Only the Contractor’s employees that are trained and certified shall operate the equipment.

The Contractor shall have a minimum of five (5) years' experience using the pipe-bursting method proposed and shall have installed no less than 50,000 feet by this method.

### **2641.3 MATERIALS**

Pipe materials meet the requirements described in Sections 2611.2 and 2621.2 of these specifications, and as provided in the Special Provisions and the following:

- (1) Sizes of the new pipe insertions shall be such to renew the pipe mainline to greater than the original flow capacity.
- (2) All pipe and fittings shall be made of virgin material. No rework except that obtained from the manufacturer’s own production of the same formulation shall be used.
- (3) The pipe shall be homogenous throughout and shall be free of visible cracks, holes, foreign material, blisters, or other deleterious faults.
- (4) Tensile strength of the pipe shall be in accordance with manufacturer’s recommendation for the specified purpose and method of installation.

- (5) Material color shall be as specified with interior of pipe having a light reflective color to allow for viewing for television inspection. The fused pipe joints shall be de-beaded to reduce collection of sediment and allow a camera to pass during inspection.
- (6) The Contractor shall consult with the selected pipe bursting equipment manufacturer regarding recommendations for the installation of pipe materials specified.

#### **2641.4 SUBMITTALS**

The Contractor shall submit the following:

- (1) Tests for compliance with this specification shall be made as specified herein and in accordance with the applicable ASTM Specification. A certificate from the manufacturer indicating the materials furnished meet the requirements of these specifications.
- (2) Shop drawings, catalog data, and manufacturer's technical data showing complete information on material composition, physical properties, and dimensions of new pipe and fittings. Include manufacturer's recommendations for handling, storage, and repair of pipe and fittings damaged.
- (3) Certification of Contractor and assigned personnel training for installing pipe.
- (4) Detailed submittal of the procedures and method proposed by the Contractor to burst the existing pipe and insert the new pipe.
- (5) Television inspection reports and video made of the existing pipe and after new pipe installation.

#### **2641.5 DELIVERY, STORAGE, AND HANDLING**

The Contractor shall transport, handle, and store pipe and fittings as recommended by the manufacturer. If new pipe and fittings become damaged before or during installation, it shall be repaired as recommended by the manufacturer or replaced as required by the Engineer at the Contractor's expense, before proceeding further. Deliver, store and handle other materials as required to prevent damage.

#### **2641.6 LICENSE AGREEMENTS**

The Contractor shall submit evidence acceptable to the Owner, such as a certified copy of a license or agreement that it has the authority to use the proposed method from the patent holder and licensed manufacturer. The Contractor agrees to defend, indemnify, and hold harmless the Owner and the Engineer against all claims, suits, and actions or other damages as a result of negligence of any person or property arising out of patent infringement by the Contractor or the Contractor's employee's, agents, the suppliers, or any tier of subcontractors involved in the work.



## **2641.7 CONSTRUCTION REQUIREMENTS**

Before excavation is started, it will be the responsibility of the Contractor to check with the various utility companies and determine the location and depth of the existing utilities in the vicinity of the work area.

Damage to utilities and the resulting repair, temporary service cost, etc., shall be borne by the Contractor. Access pits shall be backfilled in accordance with Section 2600, Trench Excavation and Backfill.

All excavations shall be properly sheeted/shored in accordance with relevant specifications for trench safety systems. Any damage resulting from improperly shored excavations shall be corrected to the satisfaction of the Engineer with no compensation to the Contractor.

All open excavations shall be kept secure at all times by the use of barricades and fencing with appropriate lights and signs, construction tape, covering with steel plates, etc., or as directed by the Engineer.

All lateral and service connections shall be identified, located and excavated prior to the pipe insertion to expedite reconnection. The Contractor shall use excavation methods that will not create a rise or sag at the service or lateral connection for gravity sewers. A rise or sag in the sewer will be repaired by the contractor at no expense to the Owner, in a manner approved by the Engineer.

The location and number of insertion and receiving excavations shall be planned by the Contractor and submitted in writing for approval by the Engineer at least ten (10) days prior to excavation.

One (1) or more receiving pits shall be excavated at the end(s) of the pipe to be replaced or at appropriate points within the length of the existing pipe. Pit shall be centered over the existing pipe. The number of pits for machine and pipe insertion shall be the minimum necessary to most efficiently accomplish the work. The Contractor shall give consideration to the use of excavation required for other purposes such as for sanitary sewer service reconnections and manhole replacement.

Where manholes are used as machine or new pipe insertion pits, the Contractor shall identify such manholes and replace them at no additional cost to the Owner if damaged. Any manhole modification or replacement required shall be considered incidental to the installation of the new pipe. Equipment used to perform the work shall be located away from buildings so as not to create noise impact. Provide a silent engine compartment to reduce machine noise as required to meet local requirements.

The Contractor shall install all pulleys, rollers, bumpers, alignment control devices, and other equipment required to protect existing manholes and pipe components not intended for removal/replacement, and to protect the new pipe from damage during installation. Lubrication may be used as recommended by the manufacturer. If lubrication is used for insertion, the Contractor shall ensure that the lubricant does not backfill existing services. Under no circumstances will the pipe be stressed beyond eighty percent (80%) of its elastic limit as published and recommended by the manufacturer.

Pipe insertion shall be continuous and without interruption from manhole to manhole for sewers, or junction to junction for watermain, except as approved by the Engineer. Upon completion of insertion of the new pipe, and after the relaxation period, the Contractor shall expedite the reconnection of laterals and services so as to minimize any inconvenience to customers. Connection of services shall be in accordance with Sections 2611 and 2621 of these specifications and as provided in the Special Provisions.

The installed pipe shall be allowed the manufacturer's recommended amount of time, but not less than four (4) hours, for cooling and relaxation due to tensile stressing prior to any reconnection of service lines, sealing of the annulus or backfilling of the insertion pit. Sufficient excess length of new pipe, but not less than four inches (4"), shall be allowed to protrude into manholes. Restraint of pipe ends shall be achieved by means of electrofusion couplings. The electrofusion couplings shall be slipped over pipe ends against manhole wall and fused in place. Installation of electrofusion couplings shall be done in accordance with the manufacturers recommended procedures.

Following the relaxation period, the annular space at the manhole shall be sealed. Sealing shall be made with material approved by the Engineer and shall extend a minimum of eight inches (8") into the manhole wall in such a manner as to form a smooth, uniform, watertight joint.

Fused pipe joints shall be de-beaded to create a smooth flow line. There shall be no ridges or burrs from the fusion method exposed on the interior of the pipe following installation.

Tracer wire shall be installed with the pipe in accordance with 2611 and 2621.

**Equipment:** The pipe bursting tool shall increase the external dimensions sufficiently, causing breakage of the existing pipe at the same time expanding the surrounding ground. Simultaneously, the new pipe, directly attached to the expander, shall also move forward. See manufacturer's specifications for what size tool should be used in what diameter of pipe, as well as parameters of what size tool for percentage of upsize allowed.

The bursting head shall incorporate a shield/expander to prevent collapse of the hole ahead of the pipe insertion.

**Bypass Pumping:** The Contractor, when and where required for sanitary sewer replacement, shall provide diversion for the pipe bursting/replacement process. The pumps and by-pass lines shall be of adequate capacity and size to handle all flows. All costs for by-pass pumping required during installation of the pipe shall be incidental to the installation of the pipe, unless otherwise provided in the Special Provisions.

**Temporary Water:** The Contractor when and where required for watermain replacement, shall provide all labor, materials, and equipment associated with managing, constructing, and maintaining a temporary potable water distribution system for all existing water users which must be taken out of service for a period exceeding eight (8) hours, or as required at the discretion of the Engineer. All costs to provide temporary water required during installation of the pipe shall be incidental to the installation of the pipe, unless otherwise provided in the Special Provisions.

## **2641.8 TESTING AND INSPECTION**

**Testing:** Tests for compliance with this specification shall be made as described herein and in accordance with the applicable ASTM Specification. A certificate with this specification shall be furnished, upon request, by the manufacturer for all material furnished under this specification.

**Inspection:** Video inspection of pipelines shall be performed by experienced personnel trained in locating breaks, obstacles, and service connections by closed circuit color television. Video inspection shall include the following:

- Two (2) copies of the DVD's in mpeg4 format (post) to be submitted to the Owner before final invoice.
- DVD's are to remain property of the Owner; Contractor to retain second copy.
- All flows tributary to reach of sewer being inspected are to be completely by-passed around the reach during inspection if necessary and required by the Owner.
- Pre-construction video of the existing pipe and post construction video inspection upon completion of reconstruction of each reach of pipe, with the voice description, with stationing of services indicated. Data and stationing to be on video.
- Should any portion of the video inspection be of inadequate quality or coverage, as determined by the Owner the Contractor will have the portion re-inspected and video recorded at no additional expense to the Owner.

## **2641.9 METHOD OF MEASUREMENT**

Measurement for pipe bursting shall be on a linear foot basis, to the nearest whole foot, measured from center of manhole to center of manhole or junction point to junction point as indicated on the plans.

## **2641.10 BASIS OF PAYMENT**

Pipe Bursting: The work performed as prescribed by this item will be paid for by the linear foot at the unit price bid for the pipe bursting/replacement at the specified pipe diameter and location which price shall be full compensation for the installation of the new pipe, furnishing and placing of all materials, labor, tools, equipment, cleaning, and preparation of the existing pipe to receive the new pipe, tracer wire, pipe bedding, backfill material, annulus sealing material and launching pits, and video inspection of final installed pipe, bypass pumping, temporary water distribution, traffic control, sealing at manholes, locating, excavating, disconnecting, testing in accordance with the Contract Documents, and all else incidental thereto for which separate payment is not provided under other Items in the Bid Form.

**APPENDIX B**

**CITY OF FRIDLEY STANDARD DETAIL PLATES  
FOR UTILITY CONSTRUCTION  
February, 2019**

# CITY OF FRIDLEY

## STANDARD DETAILS INDEX

City Plate No.

BED-1  
BED-2  
BED-3

PIPE INSTALLATION DETAILS

PIPE BEDDING METHODS FOR PVC  
PIPE BEDDING METHODS FOR RCP OR DIP  
IMPROVED FOUNDATION FOR ALL PIPES

EROSION CONTROL DETAILS

ERO-1A  
ERO-1B  
ERO-1C  
ERO-1D  
ERO-2  
ERO-3  
ERO-4A

SILT FENCE - MACHINE SLICED  
SILT FENCE - HEAVY DUTY  
SILT FENCE - STANDARD  
SILT FENCE - J HOOK  
EROSION CONTROL BLANKET INSTALLATION  
FLOATING SILT CURTAIN  
INLET PROTECTION - SILT BOX FOR CATCH BASIN

ERO-4B

BEFORE ROAD CONSTRUCTION  
INLET PROTECTION - ROCK FILTER FOR CATCH BASIN  
DURING ROAD CONSTRUCTION

ERO-4C

INLET PROTECTION - CATCH BASIN INSERT AFTER PAVING

ERO-4D

INLET PROTECTION - SILT BOX FOR BEEHIVE CASTING

ERO-5A

DITCH CHECK - 3D VIEW FOR 5B, 5C AND SPACING

ERO-5B

DITCH CHECK - ROCK WEEPER AND BIO WEEPER

ERO-5C

DITCH CHECK - SMALL CHECK DAM AND LARGE CHECK DAM

ERO-5D

DITCH CHECK - MACHINE SLICED SILT FENCE

ERO-5E

DITCH CHECK - TRIANGULAR SILT DIKE

ERO-5F

DITCH CHECK - COMPOST LOG

ERO-6A

PIPE CHECK - WOODEN WEIR

ERO-6B

PIPE CHECK - BIO ROLL WEIR AND ROCK WEIR

ERO-7

CONSTRUCTION ENTRANCE - ROCK AND WOOD CHIP

ERO-8A

TEMPORARY SEDIMENTATION BASIN - PIPE OUTLET

ERO-8B

TEMPORARY SEDIMENTATION BASIN - STANDPIPE OUTLET

ERO-9

TEMPORARY SEDIMENT TRAP

ERO-10

DIVERSION MOUND AND TEMPORARY PIPE DOWNDRAIN

ERO-11

SLOPE TRACKING

ERO-12A

SUPER DUTY PERIMETER CONTROL -  
SILT FENCE / CONCRETE BARRIER SYSTEM

ERO-12B

SUPER DUTY PERIMETER CONTROL -  
HAY BALES / CONCRETE BARRIER SYSTEM

ERO-12C

PERIMETER / SEDIMENT CONTROL - HAY BALES



STANDARD DETAILS

FRIDLEY, MINNESOTA

LAST REVISION:  
DEC 2018

CITY PLATE NO.  
INDEX - 1

# CITY OF FRIDLEY

## STANDARD DETAILS INDEX

### City Plate No.

### GENERAL DETAILS

GEN-1	TYPICAL UTILITY LOCATIONS - PUBLIC AND PRIVATE
GEN-2	MAIL BOX INSTALLATION
GEN-2A	MAIL BOX INSTALLATION
GEN-3	WETLAND BUFFER SIGN
GEN-4	WETLAND BOUNDARY SIGN
GEN-5	STRUCTURE MARKER SIGNS

### SANITARY SEWER DETAILS

SAN-1	SANITARY SEWER MANHOLE
SAN-2	SANITARY SEWER JUNCTION MANHOLE
SAN-3	SANITARY SEWER DROP INLET MANHOLE
SAN-420	SUMP PUMP DISCHARGE
SAN-5	AIR RELEASE MANHOLE
SAN-6	SEWER INSULATION

### SERVICE DETAILS

SER-1	SEWER AND WATER SERVICE CONNECTIONS
SER-2	SERVICE RISER
SER-3	SANITARY SEWER SERVICE
SER-4	TRACER WIRE NEW SERVICES
SER-5A	IRRIGATION SERVICE BY PRIVATE CONTRACTOR
SER-6	WATER SERVICE SHUT OFF LOCATION

### STORM SEWER DETAILS

STO-3	STORM SEWER JUNCTION MANHOLE W/REINFORCED TOP SLAB
STO-4	STORM SEWER JUNCTION MANHOLE W/REINFORCED TOP SLAB AND SUMP
STO-5	TYPE II CATCH BASIN MANHOLE
STO-6	CATCH BASIN MANHOLE WITH SUMP
STO-8	CATCH BASIN WITH SUMP
STO-9	2'X3' CATCH BASIN WITHOUT SUMP
STO-12	FLARED END SECTION
STO-13	RIP RAP AT OUTLETS

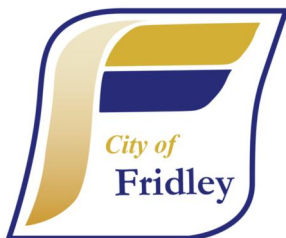

### STANDARD DETAILS

FRIDLEY, MINNESOTA

LAST REVISION:  
DEC 2018

CITY PLATE NO.  
INDEX - 2

# CITY OF FRIDLEY

## STANDARD DETAILS INDEX

### City Plate No.

STO-18  
STO-28  
STO-31  
STO-32  
STO-33

### STORM SEWER DETAILS

CATCH BASIN AND MANHOLE ADJUSTMENT  
PRECAST 27" SHALLOW DEPTH BEEHIVE  
POND OUTLET SKIMMER STRUCTURE  
TYPICAL BENCH DETAIL  
GREASE INTERCEPTOR

### PAVEMENT, CURB, WALKS DETAILS

STR-1 CURB AND GUTTER  
STR-2 CONCRETE CURB AND GUTTER CONSTRUCTION AT CATCH BASINS  
STR-3 SURMOUNTABLE CURB AND GUTTER CONSTRUCTION AT CATCH BASINS  
STR-4 CONCRETE DRIVEWAY APRON  
STR-7 PEDESTRIAN CURB RAMP  
STR-9 URBAN RESIDENTIAL DRIVEWAY APRON  
STR-10 CONCRETE VALLEY GUTTER  
STR-11 DOUBLE PERMANENT BARRICADE  
STR-19 STREET NAME BLADE SIGNS - PUBLIC STREETS  
STR-20 STREET NAME BLADE SIGNS - PRIVATE STREETS  
STR-21 TYPICAL DRIVEWAY AND CULVERT INSTALLATION  
STR-22 TYPICAL RURAL ROAD SECTION  
STR-22A TYPICAL URBAN ROAD SECTION  
STR-22B TYPICAL URBAN ROAD SECTION EDGE DRAIN  
STR-23 TYPICAL STREET TURNAROUND - RURAL SECTION  
STR-24 BITUMINOUS SAW & SEAL  
STR-25 TYPICAL BITUMINOUS TRAIL AND CONCRETE SIDEWALK  
STR-26 PLAYGROUND PLAY AREA  
STR-27 FIRE DEPARTMENT ACCESS LANE (BUILDINGS UP TO 24' HIGH)  
STR-28 FIRE DEPARTMENT ACCESS LANE (BUILDINGS OVER 24' HIGH)  
STR-29 TYPICAL PUBLIC PARKING LOT SECTION  
STR-30 TYPICAL TRAFFIC SIGN INSTALLATION BOULEVARD

### WATERMAIN DETAILS

WAT-4 GATE VALVE AND BOX  
WAT-6 CONCRETE THRUST BLOCKING  
WAT-8 HYDRANT  
WAT-10 WATERMAIN OFFSET  
WAT-11 MULTIPLE UNITS USING MAIN WATER METER  
WAT-12 MULTIPLE UNITS USING INDIVIDUAL WATER METERS



### STANDARD DETAILS

FRIDLEY, MINNESOTA

LAST REVISION:  
DEC 2018

CITY PLATE NO.  
INDEX - 3

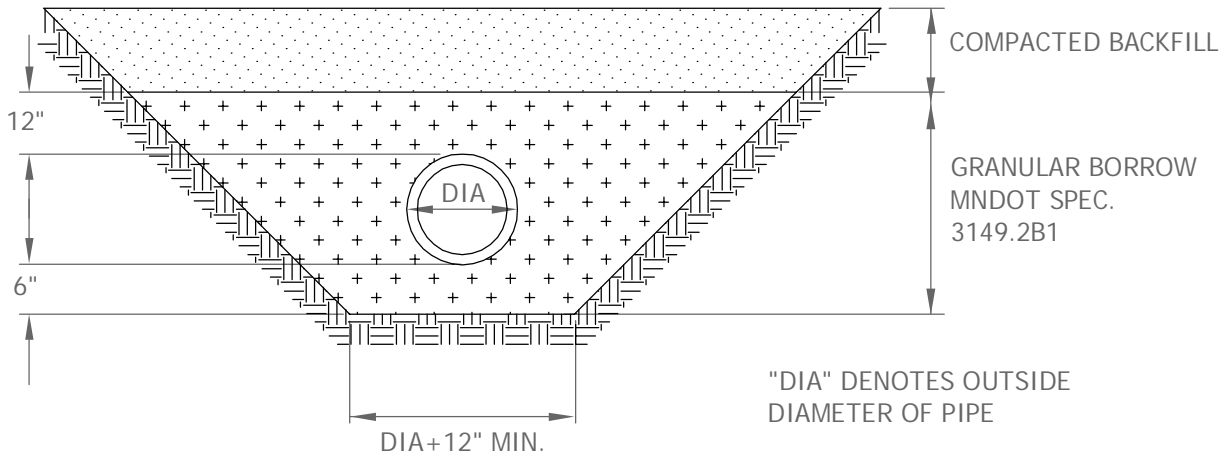

**PIPE FOUNDATION & BEDDING  
GOOD SOILS**

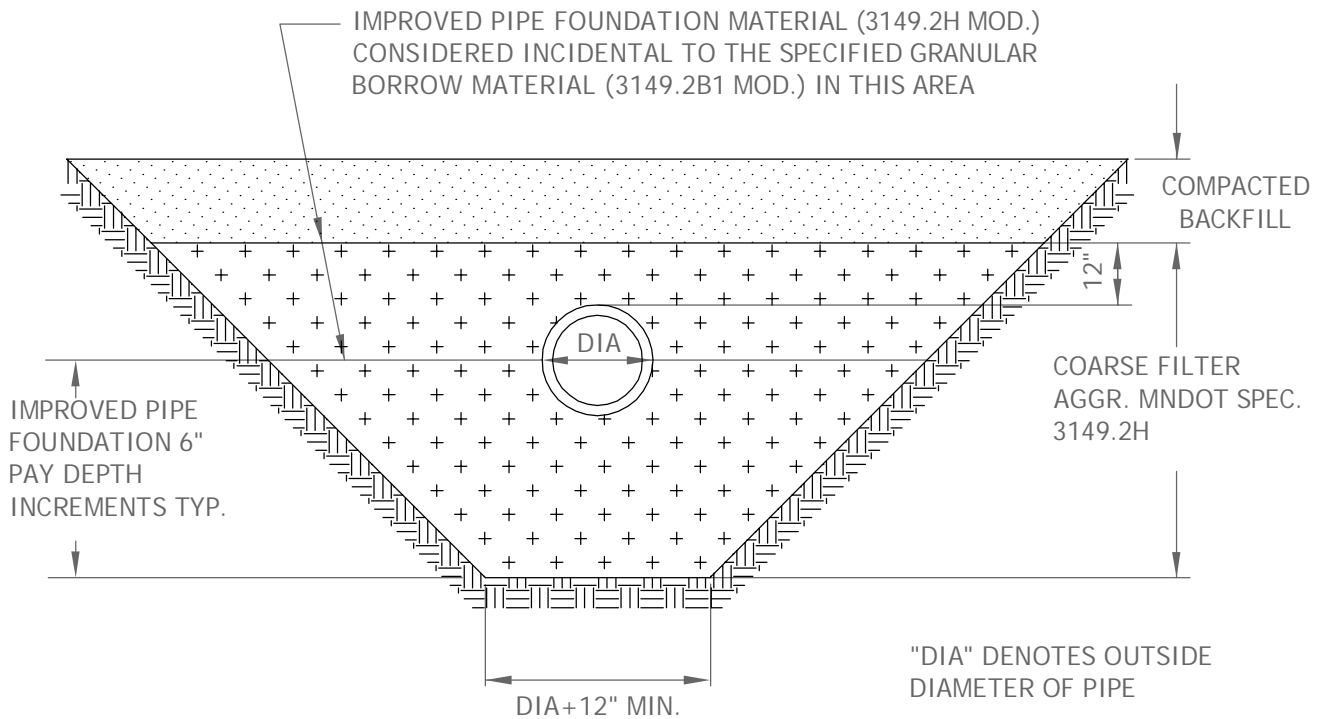

**IMPROVED PIPE FOUNDATION MATERIAL  
POOR SOILS**



**STANDARD DETAILS  
PIPE FOUNDATION & BEDDING  
METHODS FOR PVC**

**FRIDLEY, MINNESOTA**

LAST REVISION:  
DEC 2018

CITY PLATE NO.  
BED-1



"DIA" DENOTES  
OUTSIDE DIAMETER  
OF PIPE

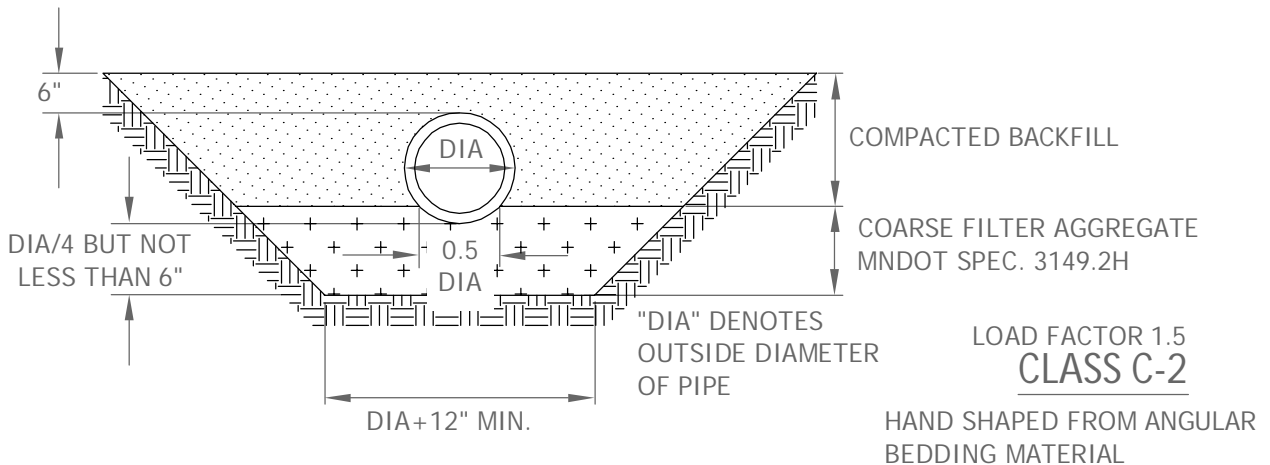
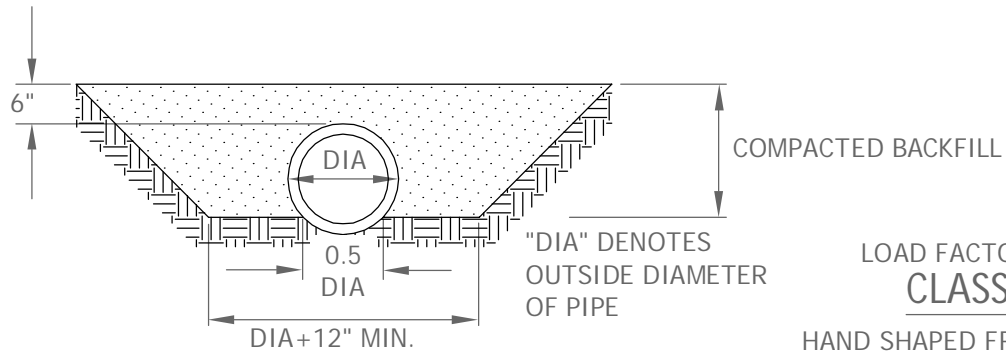
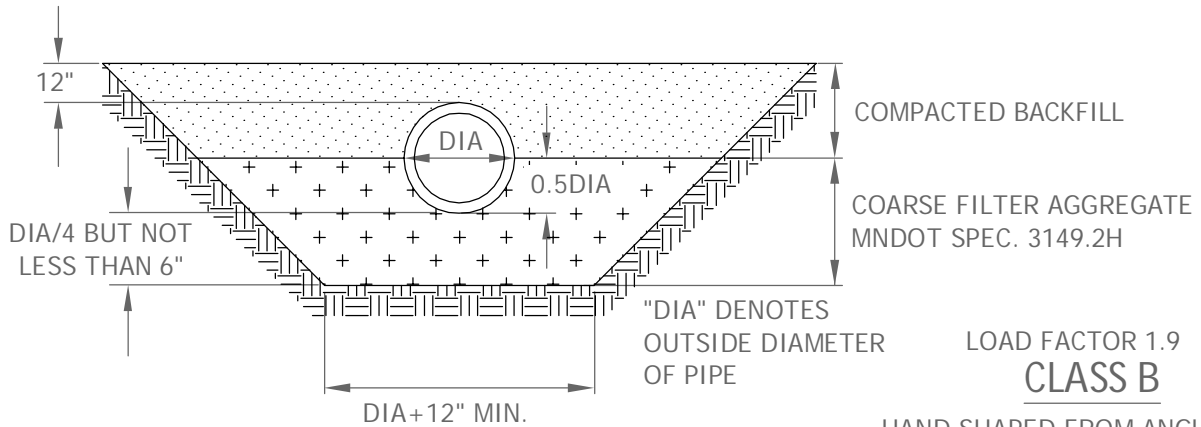

## STANDARD DETAILS

BEDDING METHODS  
FOR RCP OR DIP

# FRIDLEY, MINNESOTA

LAST REVISION:  
APRIL 2016

CITY PLATE NO.  
BED-2

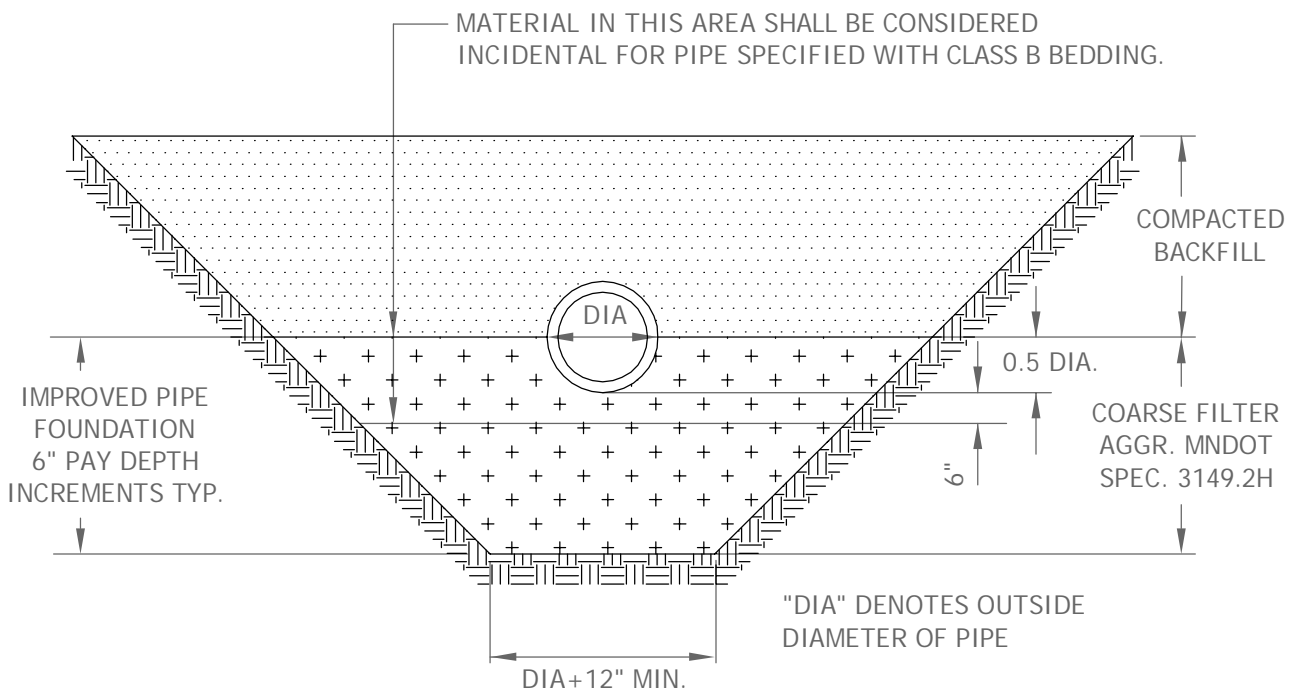

**STANDARD DETAILS**  
IMPROVED FOUNDATION FOR  
ALL PIPE TYPES

**FRIDLEY, MINNESOTA**

LAST REVISION:  
APR 2016

CITY PLATE NO.  
BED-3

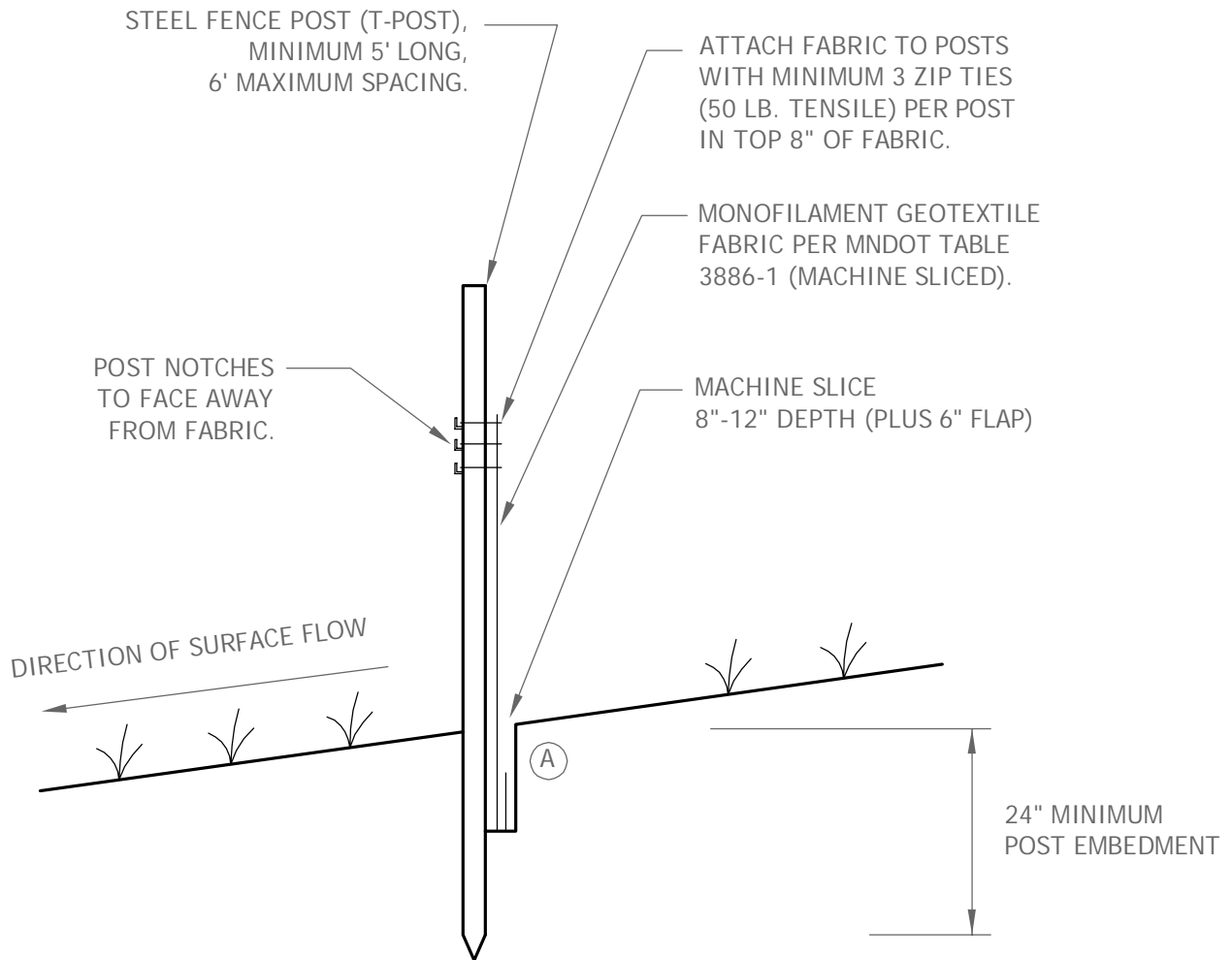

**NOTE:**  
THE MACHINE SLICED METHOD (THIS DETAIL) IS THE STANDARD SILT FENCE INSTALLATION METHOD. HEAVY-DUTY (ERO-1B) OR STANDARD (ERO-1C) SILT FENCE INSTALLATION METHODS SHOULD ONLY BE USED WHEN APPROVED OR DIRECTED BY THE CITY.

(A) **COMPACTION:**  
AFTER "SLICING" IN THE FABRIC AND *BEFORE* INSTALLATION OF STEEL POSTS, DRIVE INSTALLATION EQUIPMENT OVER THE "SLICE" WHILE FABRIC IS LAYING ON THE GROUND. *THEN* INSTALL STEEL POSTS AND PULL UP FABRIC TO ATTACH AT A UNIFORM HEIGHT.



## STANDARD DETAILS

SILT FENCE  
MACHINE SLICED

# FRIDLEY, MINNESOTA

LAST REVISION:  
DEC 2018

CITY PLATE NO.  
ERO-1A

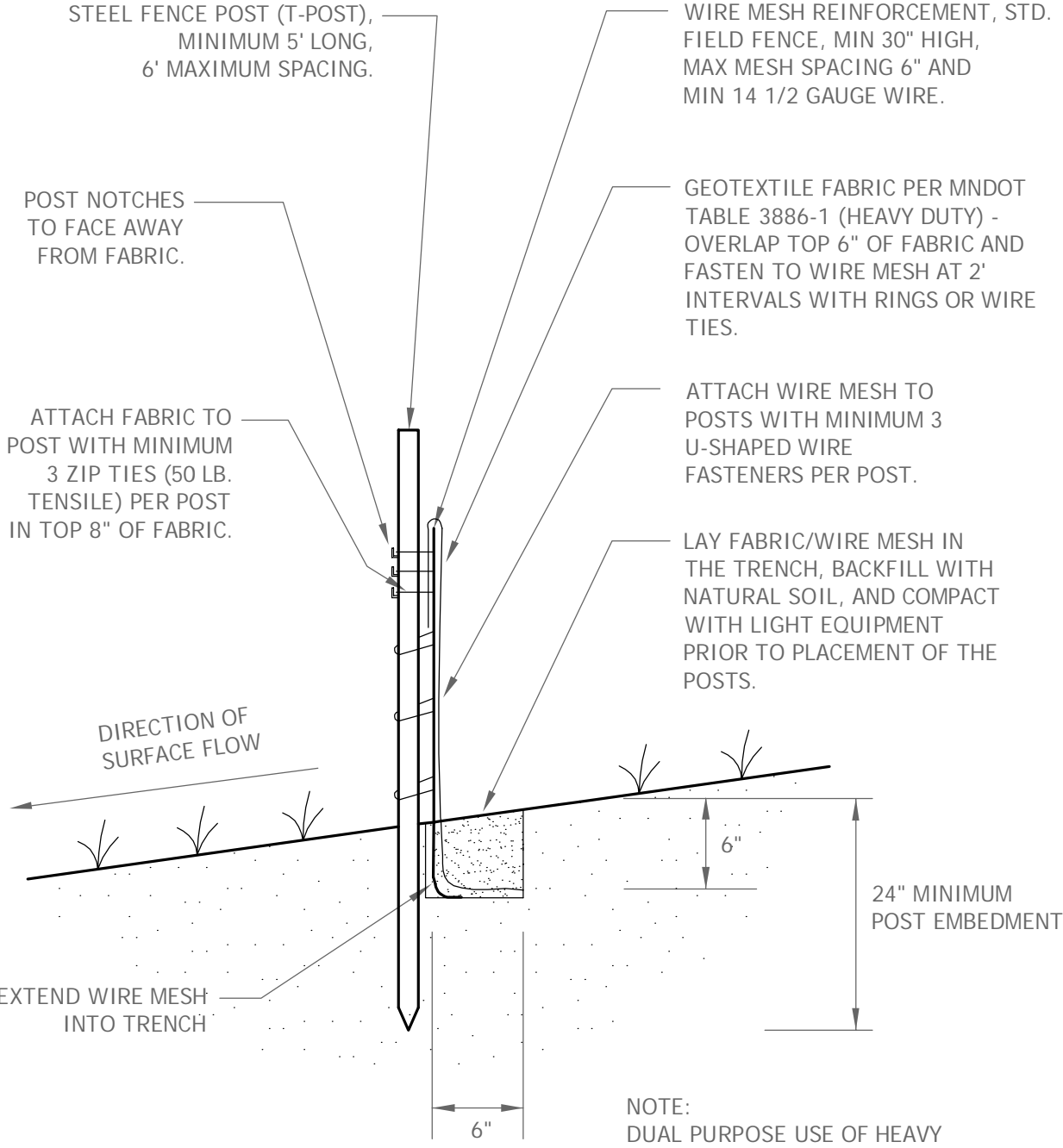

NOTE:  
HEAVY DUTY SILT FENCE FOR CURB PROTECTION REQUIRE POSTS TO BE INSTALLED ON HOUSE SIDE OF FABRIC.

NOTE:  
DUAL PURPOSE USE OF HEAVY DUTY FENCE FOR PERIMETER CONTROL AND CURB PROTECTION REQUIRE STEEL POSTS ALTERNATING ON BOTH SIDES OF FABRIC WITH 4' SPACING. SEE LAND DISTURBANCE PERMIT.



STANDARD DETAILS

SILT FENCE  
HEAVY DUTY

FRIDLEY, MINNESOTA

LAST REVISION:  
DEC 2018

CITY PLATE NO.  
ERO-1B

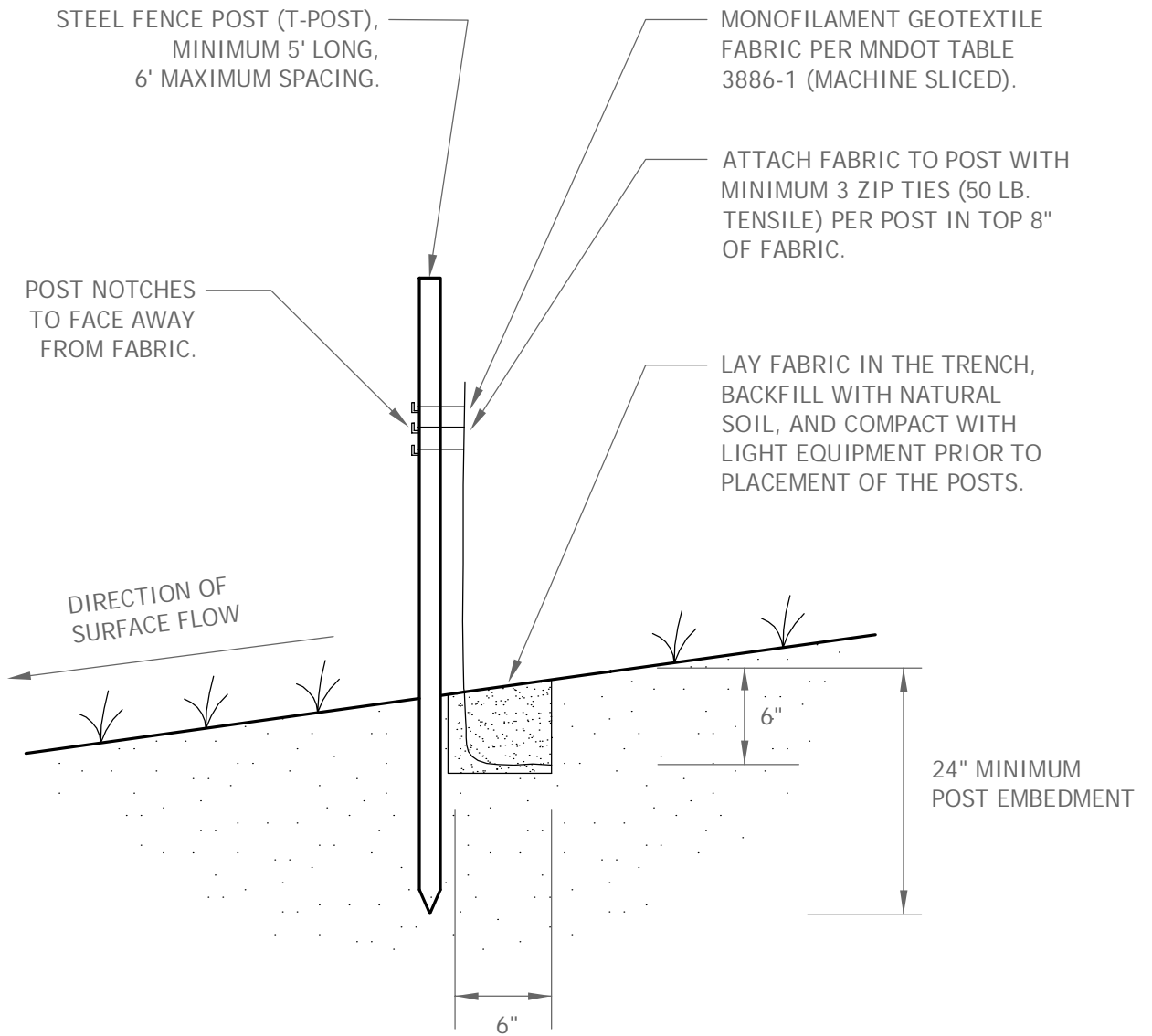

STANDARD DETAILS

SILT FENCE  
STANDARD

FRIDLEY, MINNESOTA

LAST REVISION:  
DEC 2018

CITY PLATE NO.  
ERO-1C

# PLAN VIEW

## I. SPACING REQUIREMENTS

DIRECTION OF SURFACE FLOW

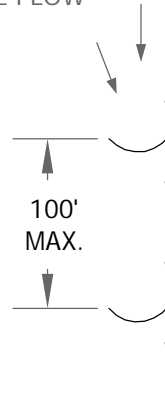

NOTE: SPACING DISTANCES WILL VARY, BUT ARE NOT TO EXCEED 100 FEET.

## II. SIZING REQUIREMENTS: J15, J25

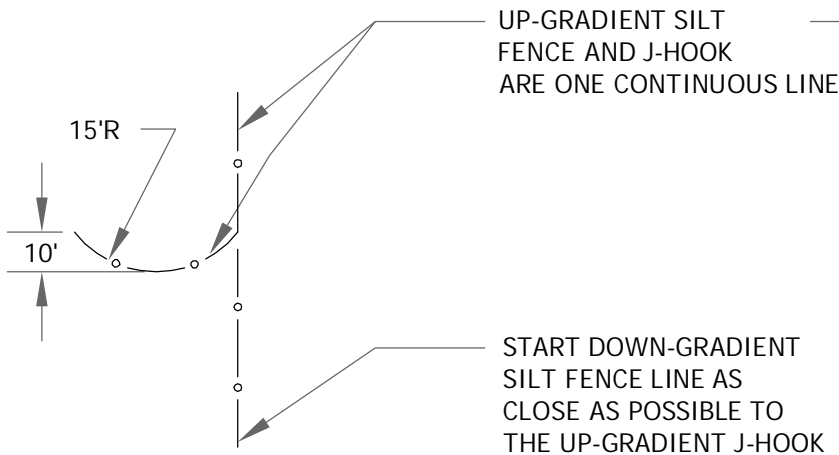

J15 - FOR CATCHMENT AREA < 0.25 ACRES

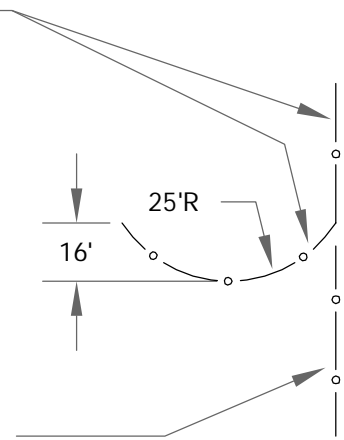

J25 - FOR CATCHMENT AREA ≥ 0.25 ACRES

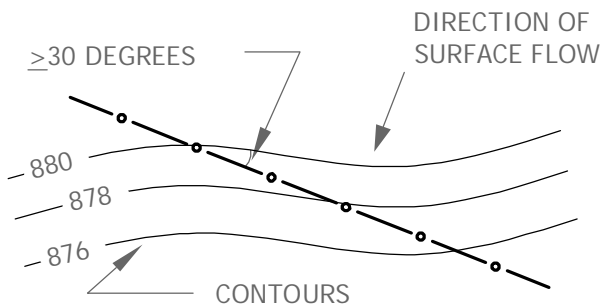

NOTE: J-HOOKS SHALL BE USED WHEN THE SILT FENCE IS INSTALLED AT AN ANGLE OF 30 DEGREES OR GREATER FROM PARALLEL TO THE CONTOURS.



### STANDARD DETAILS

SILT FENCE  
J - HOOK

FRIDLEY, MINNESOTA

LAST REVISION:  
DEC 2018

CITY PLATE NO.  
ERO-1D

ANCHOR TRENCH  
(SEE DETAIL AND NOTES BELOW)

OVERLAP END JOINTS  
MINIMUM OF 6" AND STAPLE  
OVERLAP AT 1.5' INTERVALS.

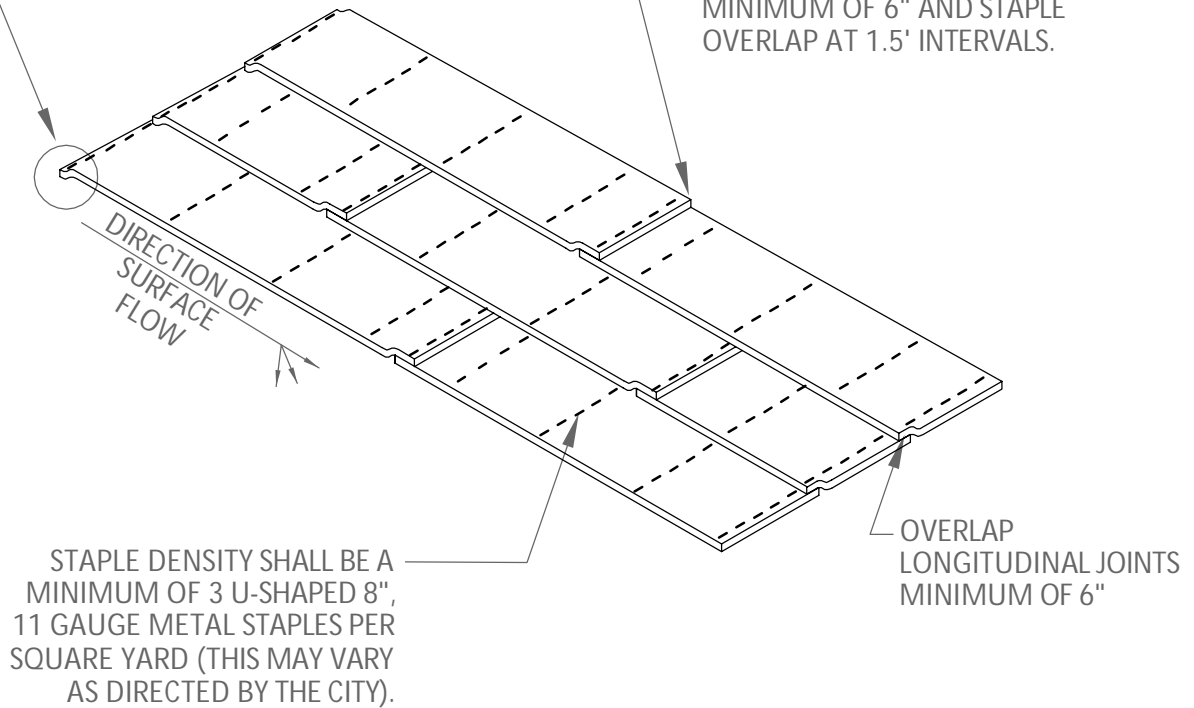

- ANCHOR TRENCH
1. DIG 6" X 6" TRENCH
  2. LAY BLANKET IN TRENCH
  3. STAPLE AT 1.5' INTERVALS
  4. BACKFILL WITH NATURAL SOIL AND COMPACT
  5. BLANKET LENGTH SHALL NOT EXCEED 100' WITHOUT AN ANCHOR TRENCH

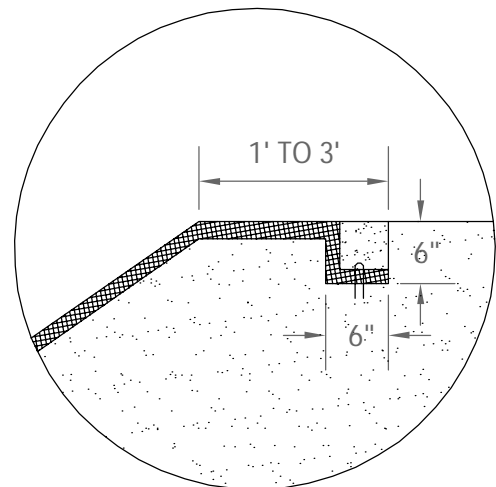

STANDARD DETAILS  
EROSION CONTROL BLANKET  
INSTALLATION

FRIDLEY, MINNESOTA

LAST REVISION:  
DEC 2018

CITY PLATE NO.  
ERO-2

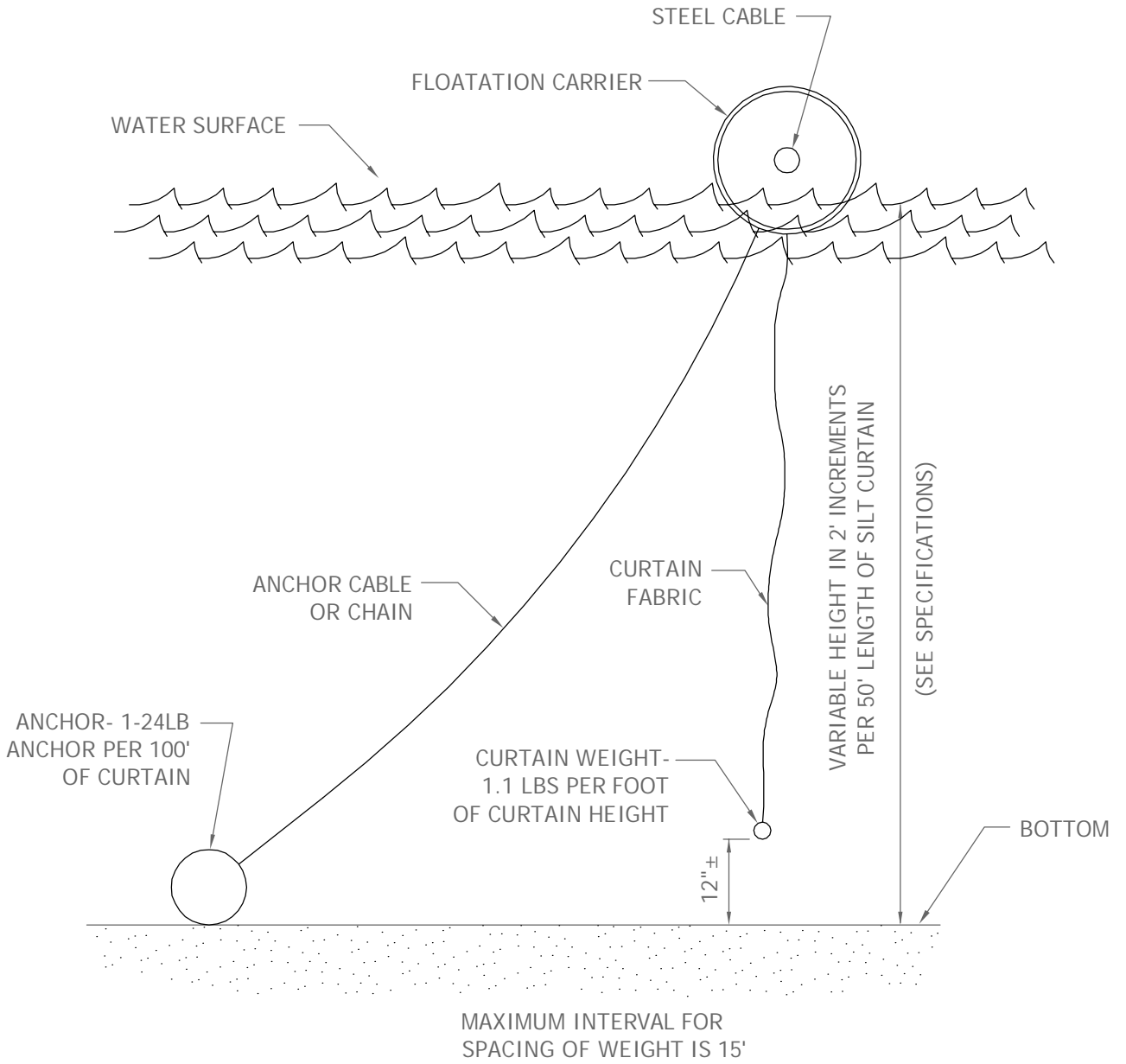

MAXIMUM INTERVAL FOR SPACING OF WEIGHT IS 15'

**NOTES:**

- DOUBLE SILT CURTAINS SHOULD BE SPACED 10' APART.
- CURTAIN LENGTH TO MATCH BOTTOM PROFILE AS CLOSELY AS POSSIBLE.



STANDARD DETAILS  
FLOATING SILT CURTAIN

**FRIDLEY, MINNESOTA**

LAST REVISION:  
DEC 2018

CITY PLATE NO.  
ERO-3



WOODEN LATH SHALL BE NAILED SECURELY TO THE POST MEMBER TO SECURE FILTER FABRIC.

2" X 4" HORIZONTAL MEMBERS CONTINUOUS AROUND TOP AND BOTTOM. FASTENED TO EACH POST USING 2-20D COMMON NAILS

2" X 4" X 2.5' LONG WOOD POSTS, 8 REQ'D.

MONOFILAMENT GEOTEXTILE FABRIC AS PER MNDOT TABLE 3886-1 (MACHINE SLICED). ADDITIONAL 8-10" OF FABRIC FLAP AT BOTTOM OF BOX

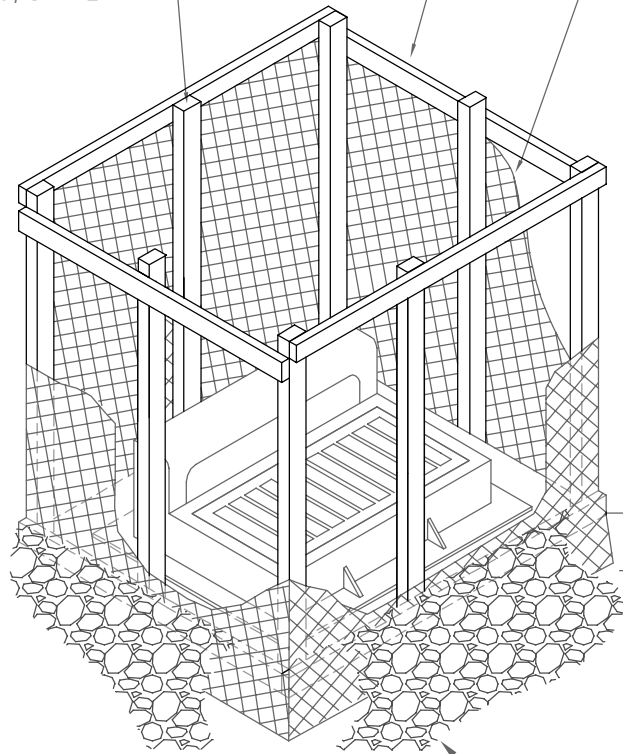

2'-6"

8-10" FABRIC FLAP EXTENDING BEYOND BOTTOM 2"x4" - BURY UNDER ROCK TO PREVENT UNDERWASHING

1 1/2" WASHED ROCK  
1' DEEP X 1' WIDE

**NOTES:**  
CONTRACTOR SHALL CONSTRUCT SILT BOX TO FIT AROUND THE INLET STRUCTURE WITH 6" MINIMUM CLEARANCE TO EDGES OF STRUCTURE. SILT BOX TO BE PLACED ON AN EVEN SURFACE 6" BELOW STRUCTURE OPENING. TOP OF SILT BOX TO EXTEND 18" MINIMUM ABOVE EXISTING GRADE.



**STANDARD DETAILS**  
**INLET PROTECTION SILT BOX**  
**FOR CATCH BASIN BEFORE CONSTRUCTION**

**FRIDLEY, MINNESOTA**

LAST REVISION:  
DEC 2018

CITY PLATE NO.  
ERO-4A

PLAN

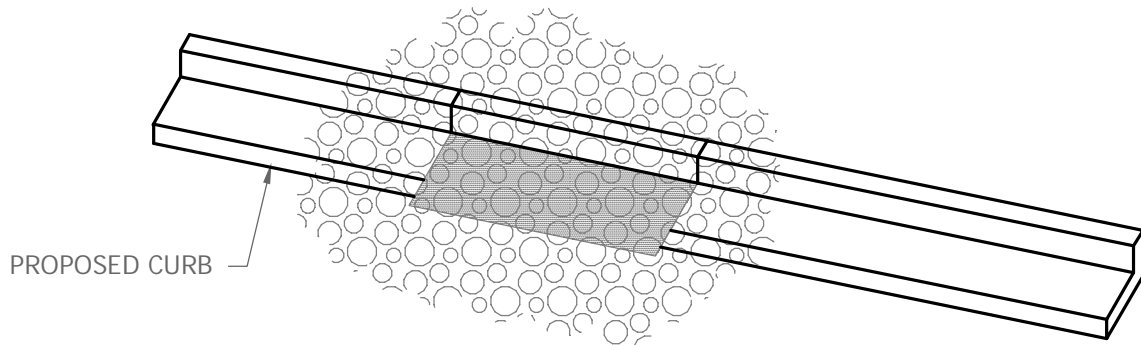

← ← = DIRECTION OF SURFACE FLOW

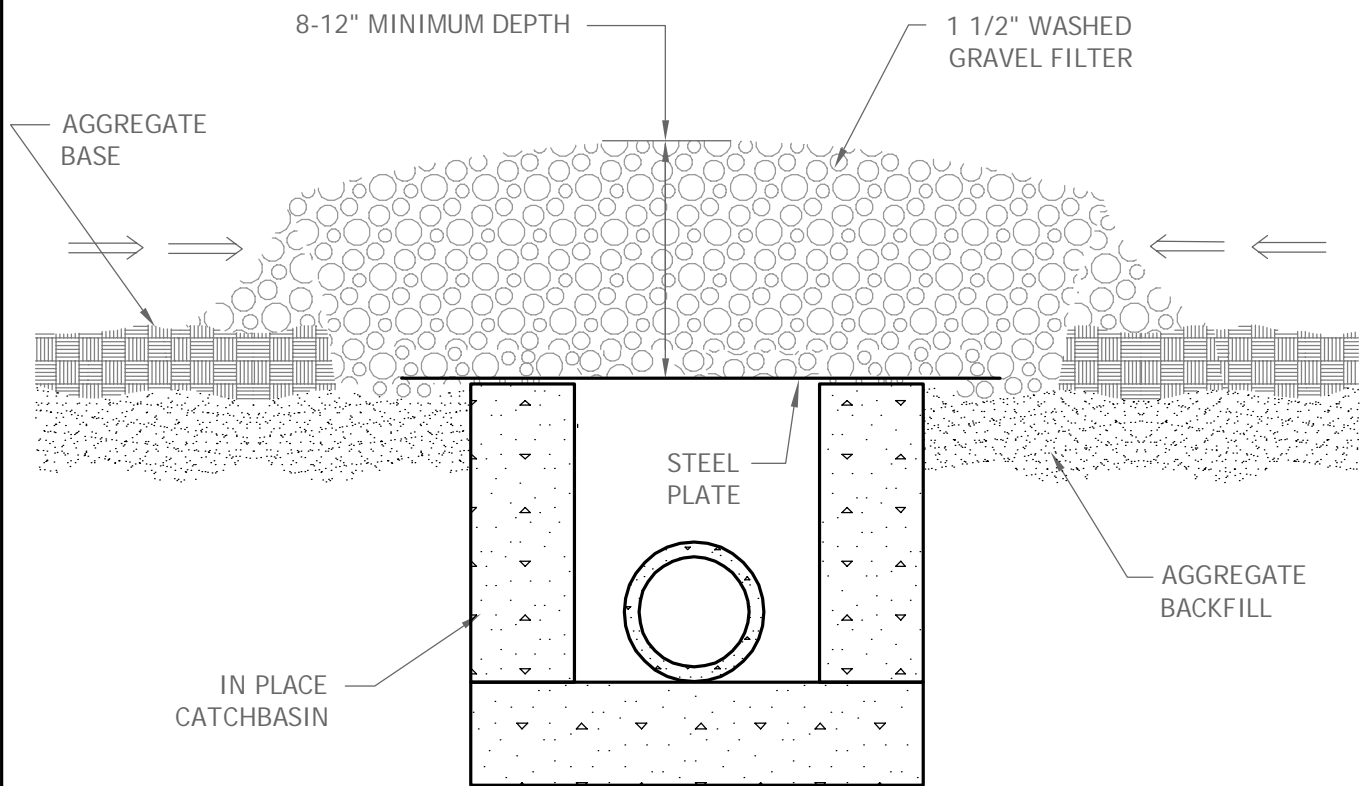

STANDARD DETAILS  
INLET PROTECTION ROCK FILTER FOR  
CATCH BASIN DURING ROAD CONSTRUCTION

FRIDLEY, MINNESOTA

LAST REVISION:  
DEC 2018

CITY PLATE NO.  
ERO-4B

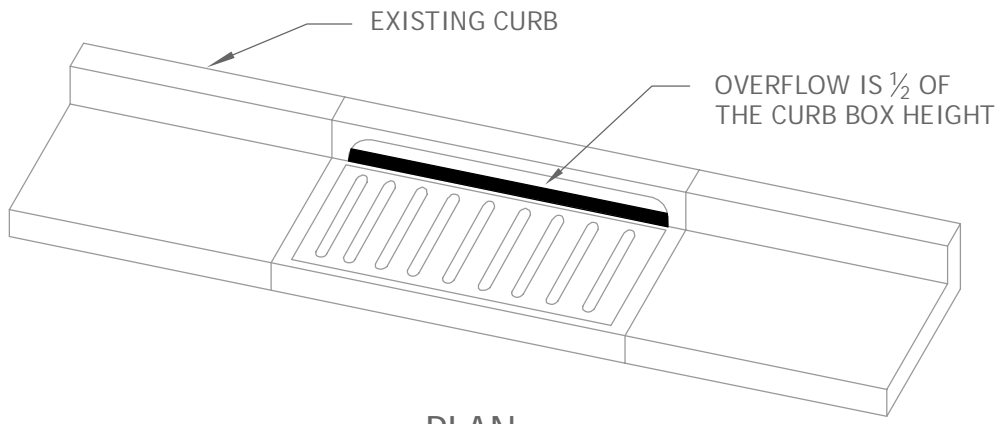

PLAN

WIMCO ROAD DRAIN CG-23\* HIGH FLOW  
INLET PROTECTION CURB AND GUTTER MODEL  
OR CITY APPROVED EQUAL.

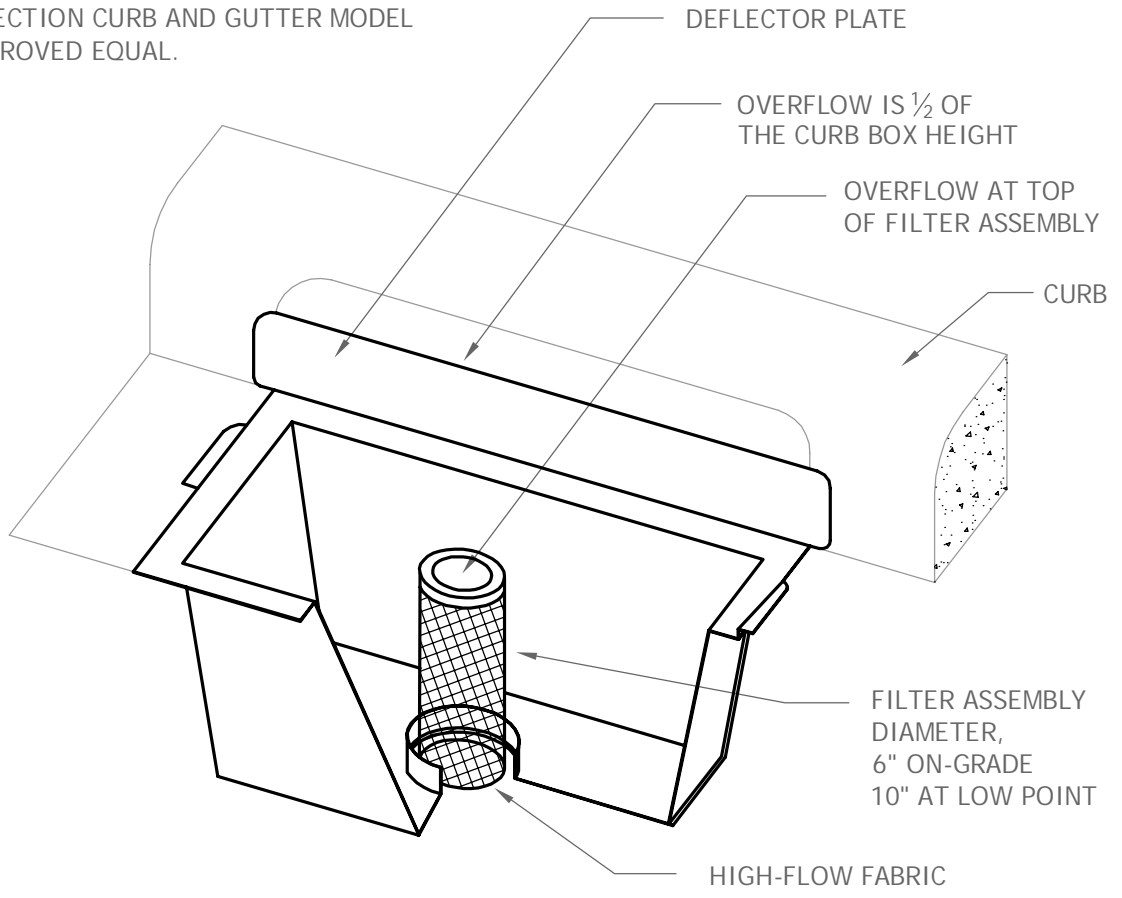

\* FOR THE NEW R-3067-VB STANDARD CASTING,  
INSTALL WIMCO ROAD DRAIN  
CG-3290 OR CITY APPROVED EQUAL.



STANDARD DETAILS  
INLET PROTECTION  
CATCH BASIN INSERT AFTER PAVING  
**FRIDLEY, MINNESOTA**

LAST REVISION:  
DEC 2018

CITY PLATE NO.  
ERO-4C

WOODEN LATH SHALL BE NAILED SECURELY TO THE POST MEMBER TO SECURE FILTER FABRIC.

2" X 4" HORIZONTAL MEMBERS CONTINUOUS AROUND TOP AND BOTTOM. FASTENED TO EACH POST USING 2-20D COMMON NAILS

2" X 4" X 2.5' LONG WOOD POSTS, 8 REQ'D.

MONOFILAMENT GEOTEXTILE FABRIC AS PER MNDOT TABLE 3886-1 (MACHINE SLICED). ADDITIONAL 8-10" OF FABRIC FLAP AT BOTTOM OF BOX

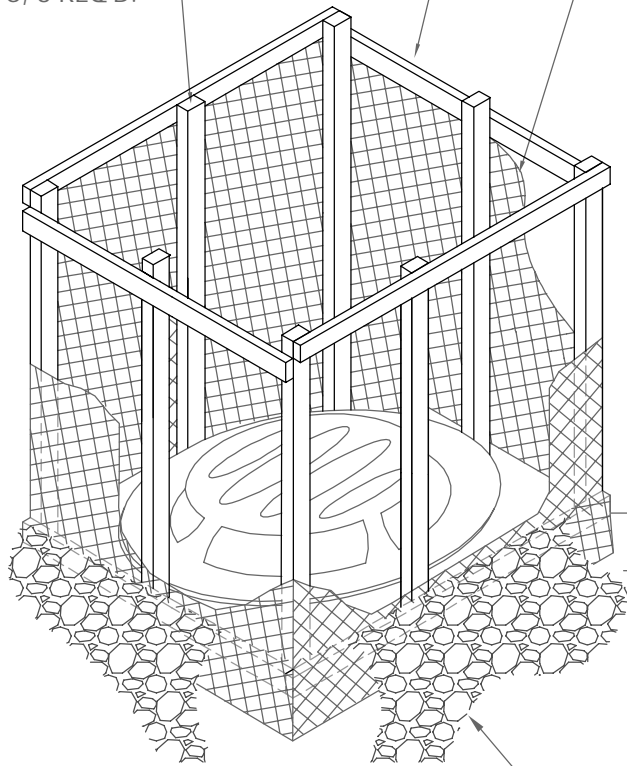

2'-6"

8-10" FABRIC FLAP EXTENDING BEYOND BOTTOM 2"x4" - BURY UNDER ROCK TO PREVENT UNDERWASHING

1 1/2" WASHED ROCK  
1' DEEP X 1' WIDE

**NOTES:**

CONTRACTOR SHALL CONSTRUCT SILT BOX TO FIT AROUND THE INLET STRUCTURE WITH 6" MINIMUM CLEARANCE TO EDGES OF STRUCTURE. SILT BOX TO BE PLACED ON AN EVEN SURFACE 6" BELOW STRUCTURE OPENING. TOP OF SILT BOX TO EXTEND 18" MINIMUM ABOVE EXISTING GRADE.



**STANDARD DETAILS**  
**INLET PROTECTION**  
**SILT BOX FOR BEEHIVE CASTING**

**FRIDLEY, MINNESOTA**

LAST REVISION:  
DEC 2018

CITY PLATE NO.  
ERO-4D

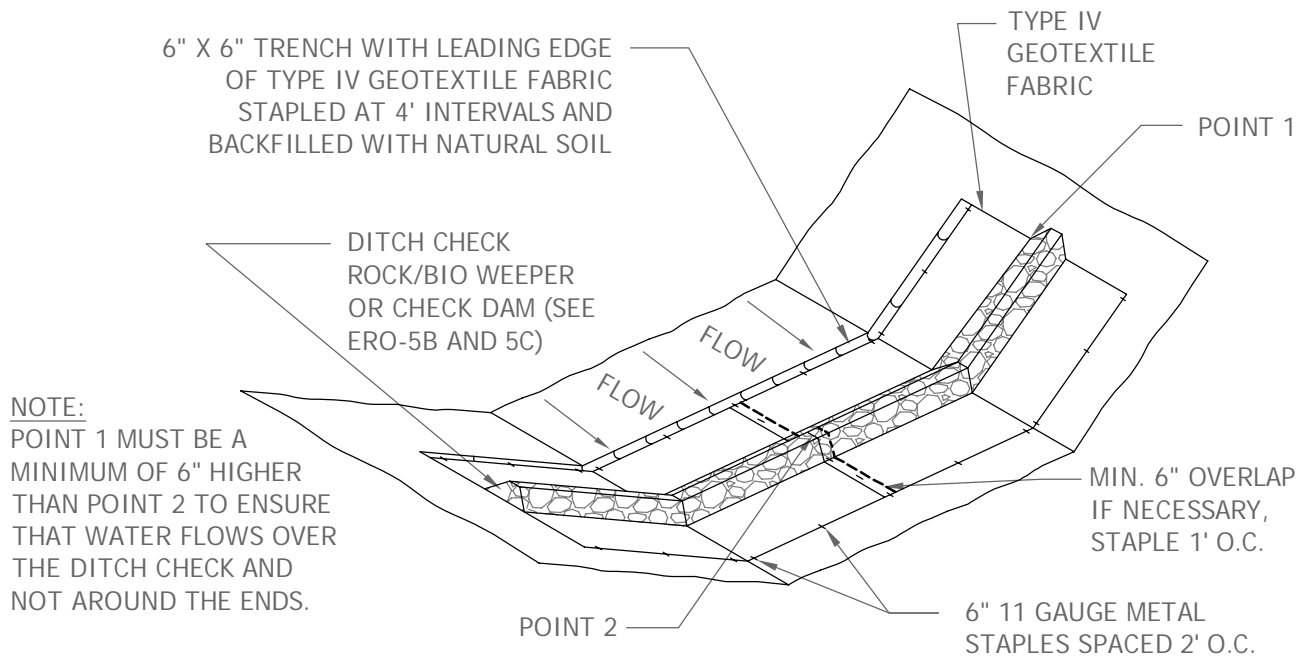

DITCH CHECK SPACING  
(USE FOR DETAILS ERO-5B, 5C, 5D, AND 5E)

DITCH GRADE	INTERVAL
(%)	(FT)
2	100
4	75
6	50
8	40
10	25
10+	25



STANDARD DETAILS  
DITCH CHECK  
3D VIEW FOR 5B, 5C SPACING  
**FRIDLEY, MINNESOTA**

LAST REVISION:  
DEC 2018

CITY PLATE NO.  
ERO-5A

## I. ROCK WEEPER

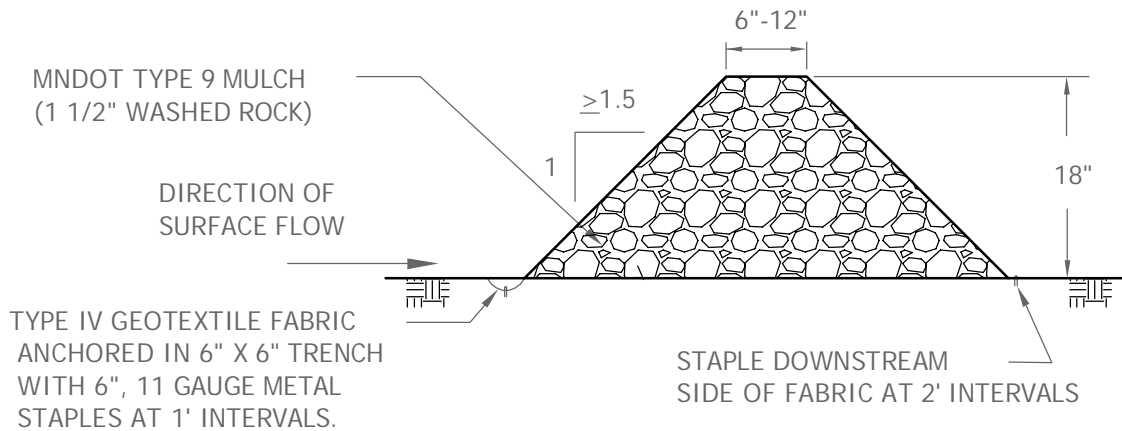

## II. BIO WEEPER

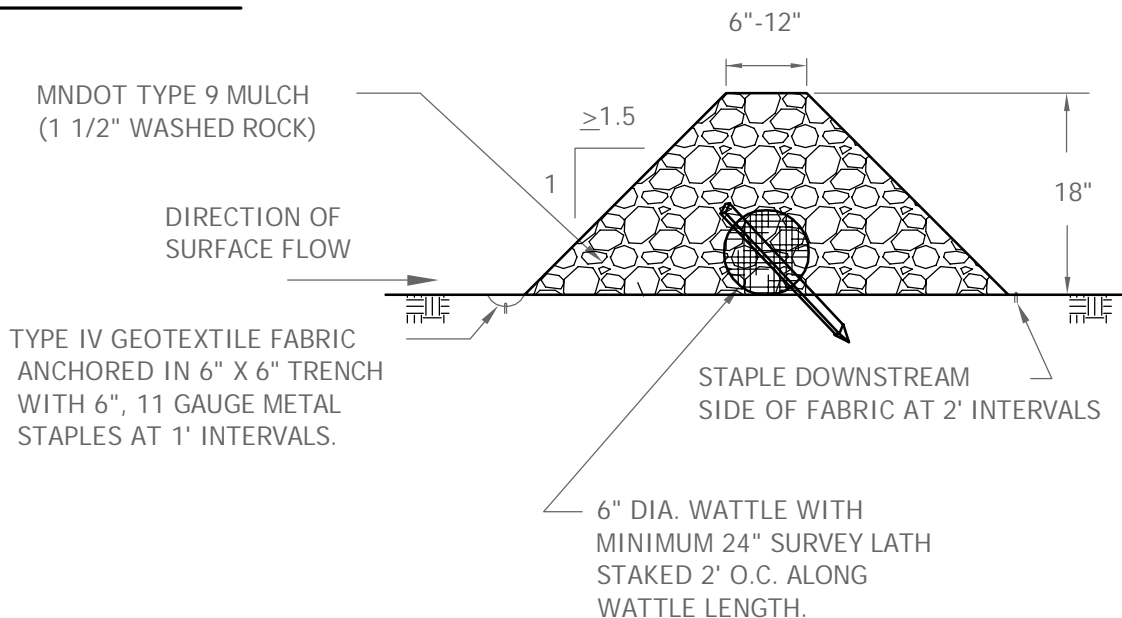

STANDARD DETAILS  
DITCH CHECK  
ROCK WEEPER, BIO WEEPER

**FRIDLEY, MINNESOTA**

LAST REVISION:  
DEC 2018

CITY PLATE NO.  
ERO-5B

## I. SMALL CHECK DAM

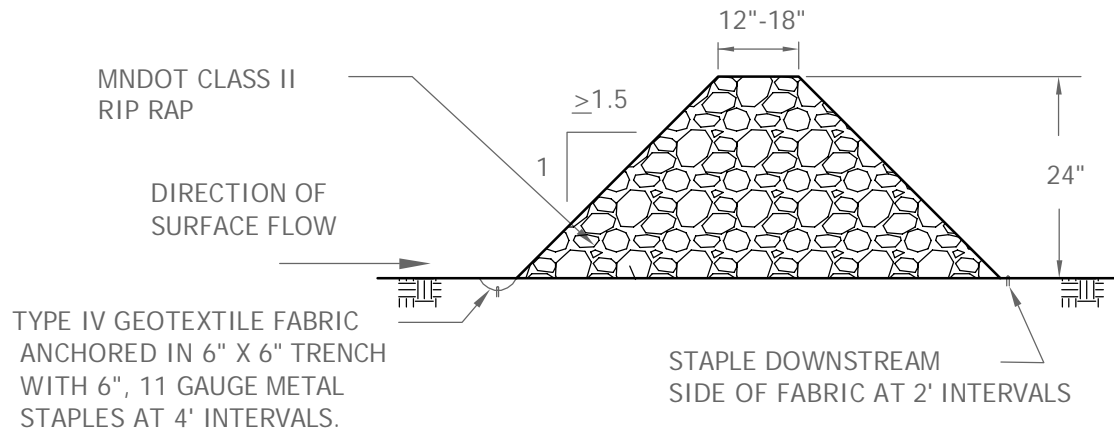

## II. LARGE CHECK DAM

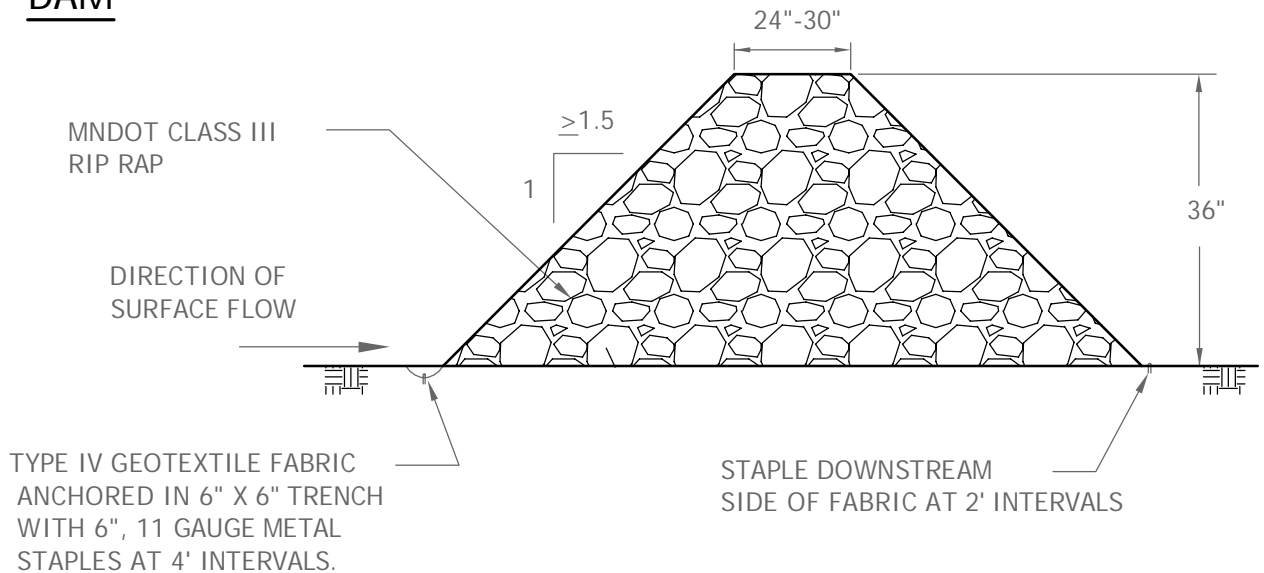

STANDARD DETAILS  
DITCH CHECK  
ROCK WEEPER, BIO WEEPER

**FRIDLEY, MINNESOTA**

LAST REVISION:  
DEC 2018

CITY PLATE NO.  
ERO-5C

NOTE:

POINT 1 MUST BE A MINIMUM 6" HIGHER THAN POINT 2 TO ENSURE THAT WATER FLOWS OVER THE SILT FENCE AND NOT AROUND THE ENDS.

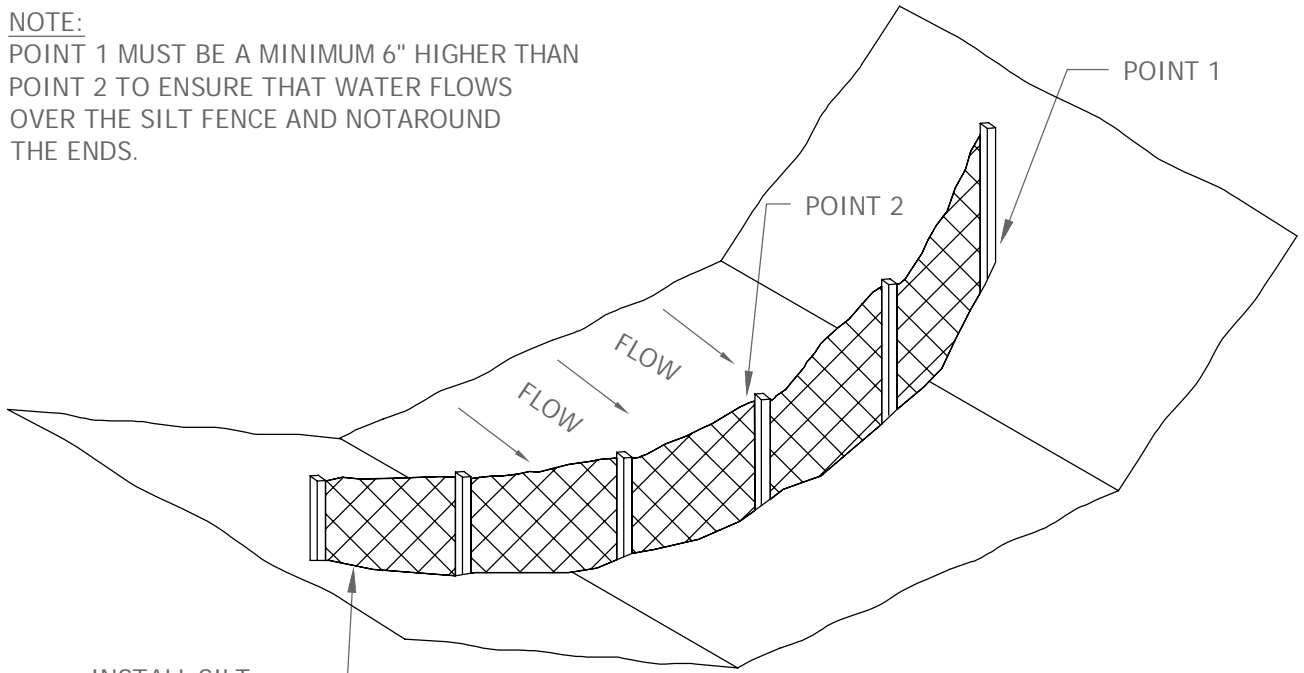

INSTALL SILT FENCE AS SHOWN BELOW

STEEL FENCE POST (T-POST),  
MINIMUM 5' LONG,  
4' MAXIMUM SPACING.

POST NOTCHES  
TO FACE AWAY  
FROM FABRIC.

ATTACH FABRIC TO POSTS  
WITH MINIMUM 3 ZIP TIES  
(50 LB. TENSILE) PER POST  
IN TOP 8" OF FABRIC.

MONOFILAMENT GEOTEXTILE  
FABRIC PER MNDOT TABLE  
3886-1 (MACHINE SLICED).

MACHINE SLICE  
8"-12" DEPTH (PLUS 6" FLAP)

DIRECTION OF SURFACE FLOW

24" MINIMUM  
POST EMBEDMENT

(A) COMPACTION:  
AFTER "SLICING" IN THE FABRIC AND  
*BEFORE* INSTALLATION OF STEEL POSTS, DRIVE INSTALLATION  
EQUIPMENT OVER THE "SLICE" WHILE FABRIC IS LAYING ON THE  
GROUND. *THEN* INSTALL STEEL POSTS AND PULL UP FABRIC TO  
ATTACH AT A UNIFORM HEIGHT.



STANDARD DETAILS  
DITCH CHECK  
MACHINE SLICED SILT FENCE

FRIDLEY, MINNESOTA

LAST REVISION:  
DEC 2018

CITY PLATE NO.  
ERO-5D



**NOTE:**  
POINT 1 MUST BE A MINIMUM OF 6"  
HIGHER THAN POINT 2 TO ENSURE  
THAT WATER FLOWS OVER THE DIKE  
AND NOT AROUND THE ENDS.

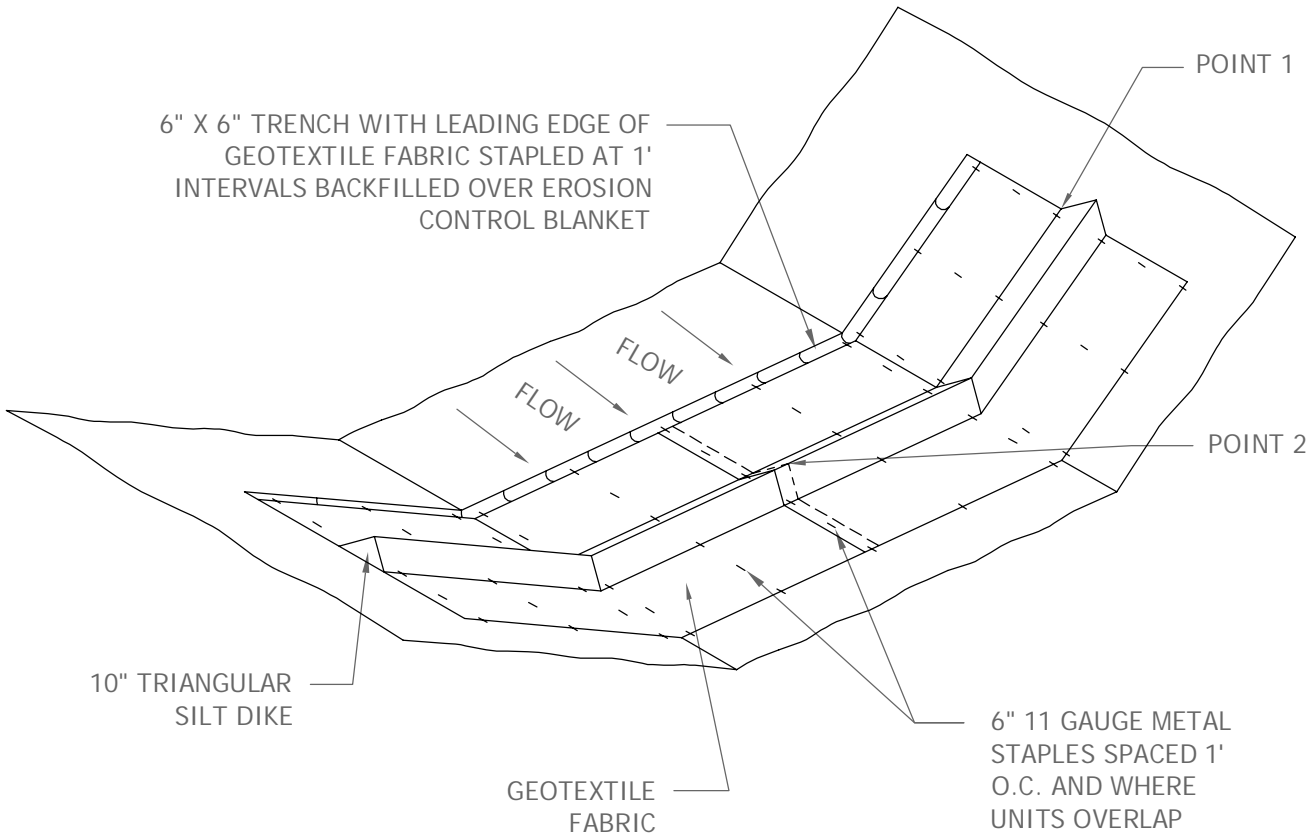

**STANDARD DETAILS**  
DITCH CHECK  
TRIANGULAR SILT DIKE

**FRIDLEY, MINNESOTA**

LAST REVISION:  
DEC 2018

CITY PLATE NO.  
ERO-5E

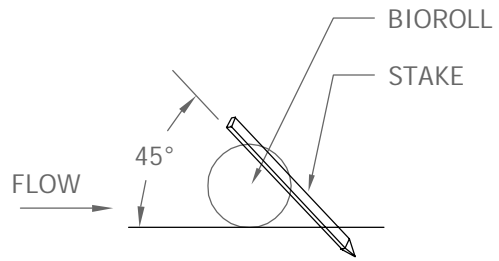
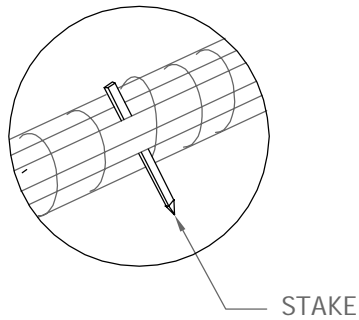

1/2" x 2" x 16" LONG WOODEN STAKES AT 1'-0" SPACING MINIMUM. STAKES SHALL BE DRIVEN THROUGH THE BACK HALF OF THE COMPOST LOG AT AN ANGLE OF 45° WITH THE TOP OF THE STAKE POINTING UPSTREAM.

**NOTE:**  
POINT 1 MUST BE A MINIMUM OF 6" HIGHER THAN POINT 2 TO ENSURE THAT WATER FLOWS OVER THE DIKE AND NOT AROUND THE ENDS.

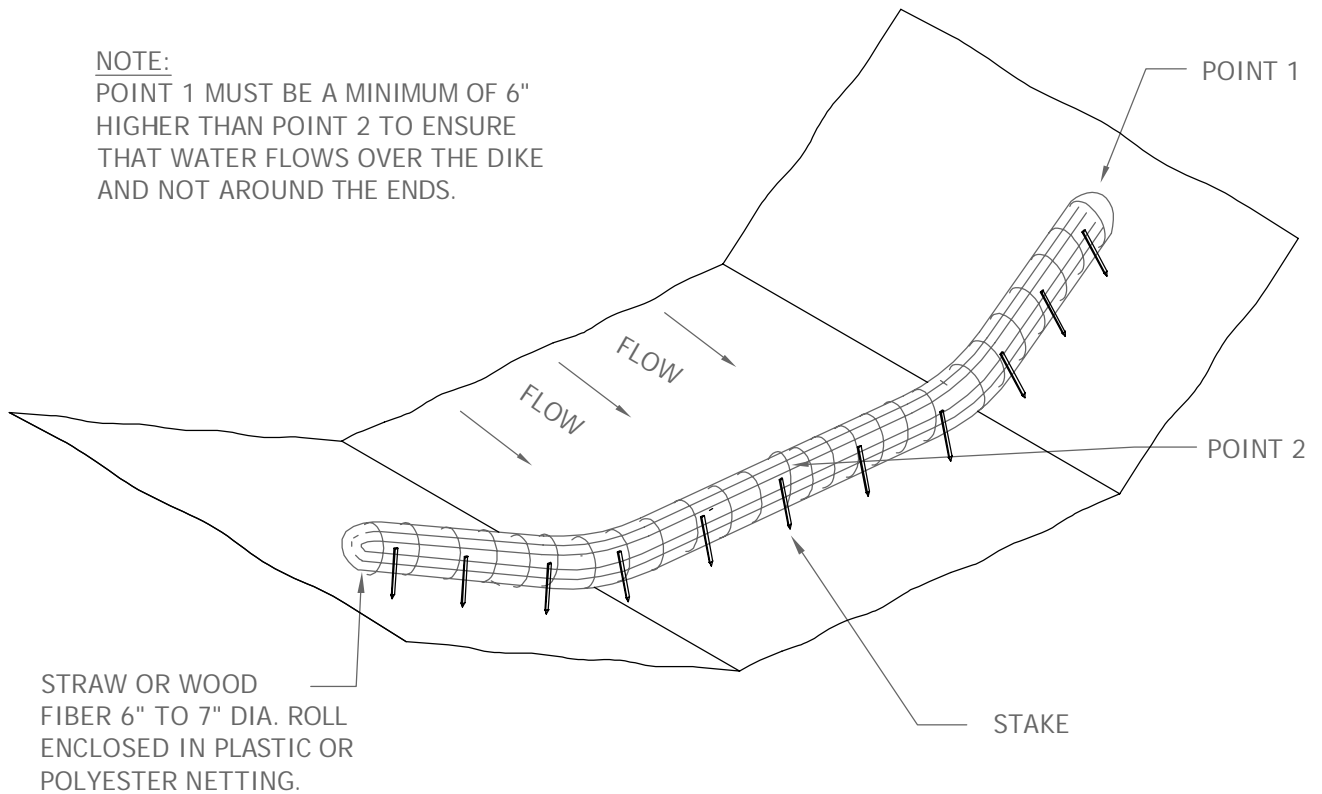

STANDARD DETAILS

COMPOST LOG  
DITCH CHECK

FRIDLEY, MINNESOTA

LAST REVISION:  
DEC 2018

CITY PLATE NO.  
ERO-5F

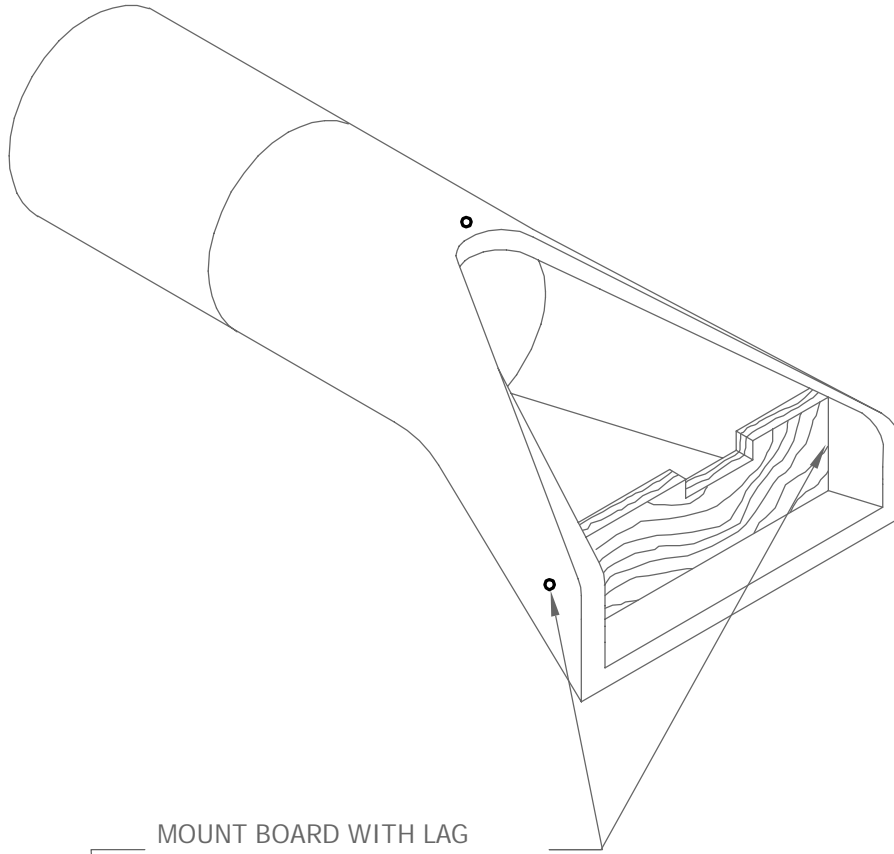

MOUNT BOARD WITH LAG BOLTS THROUGH TRASH GUARD MOUNTING HOLES.

LENGTH OF NOTCH NOT TO EXCEED 33% OF PIPE DIAMETER AND NEVER MORE THAN 12".

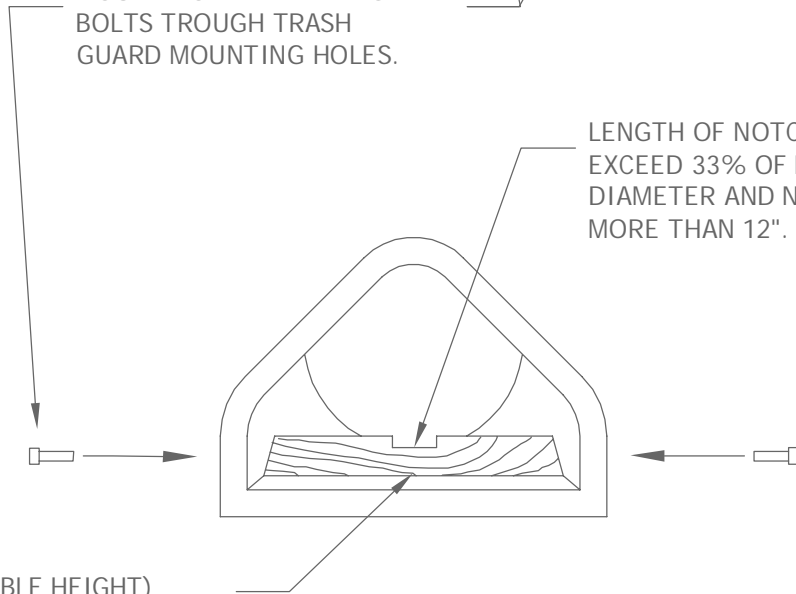

WEIR (2" x VARIABLE HEIGHT) NOT MORE THAN 33% OF PIPE DIAMETER AND NEVER MORE THAN 12".

NOTE:  
 1" NOTCH FOR WEIRS 4"-6" HIGH  
 2" NOTCH FOR WEIRS 6"-12" HIGH



STANDARD DETAILS

PIPE CHECK  
 WOODEN WEIR

FRIDLEY, MINNESOTA

LAST REVISION:  
 DEC 2018

CITY PLATE NO.  
 ERO-6A

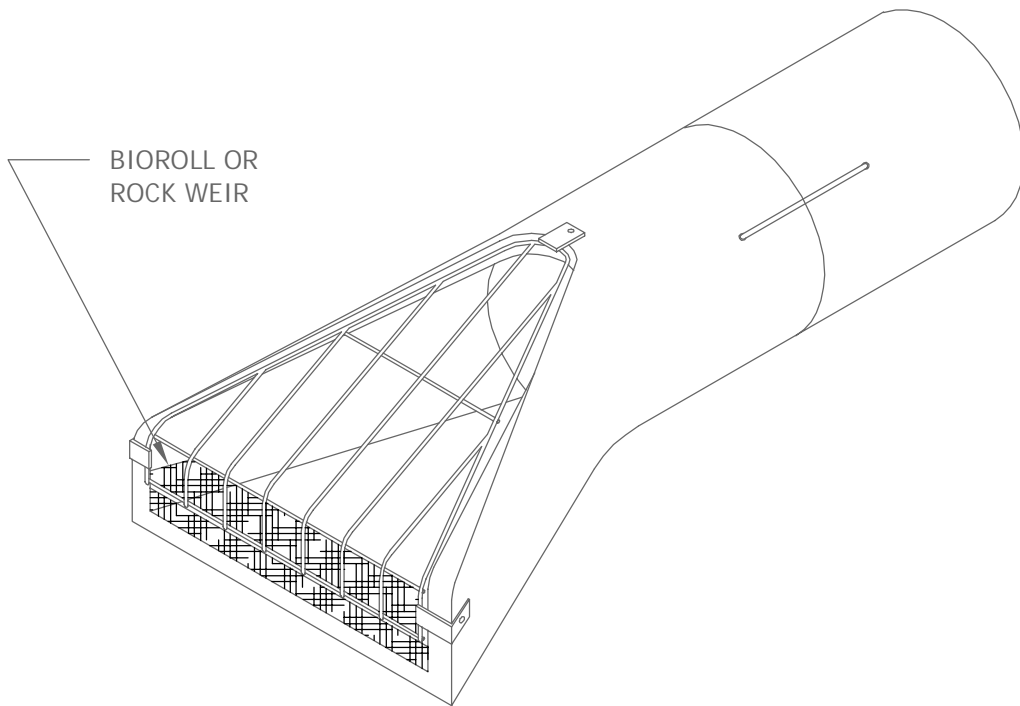

BIOROLL WEIR

ROCK WEIR

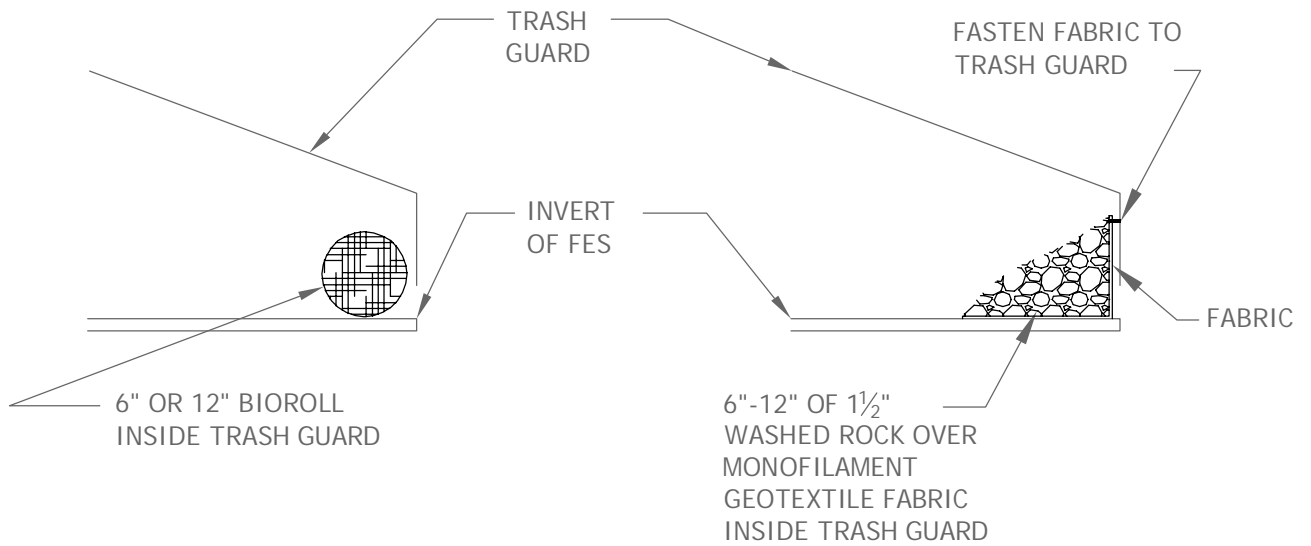

STANDARD DETAILS  
 PIPE CHECK  
 BIOROLL WEIR, ROCK WEIR

**FRIDLEY, MINNESOTA**

LAST REVISION:  
 DEC 2018

CITY PLATE NO.  
 ERO-6B

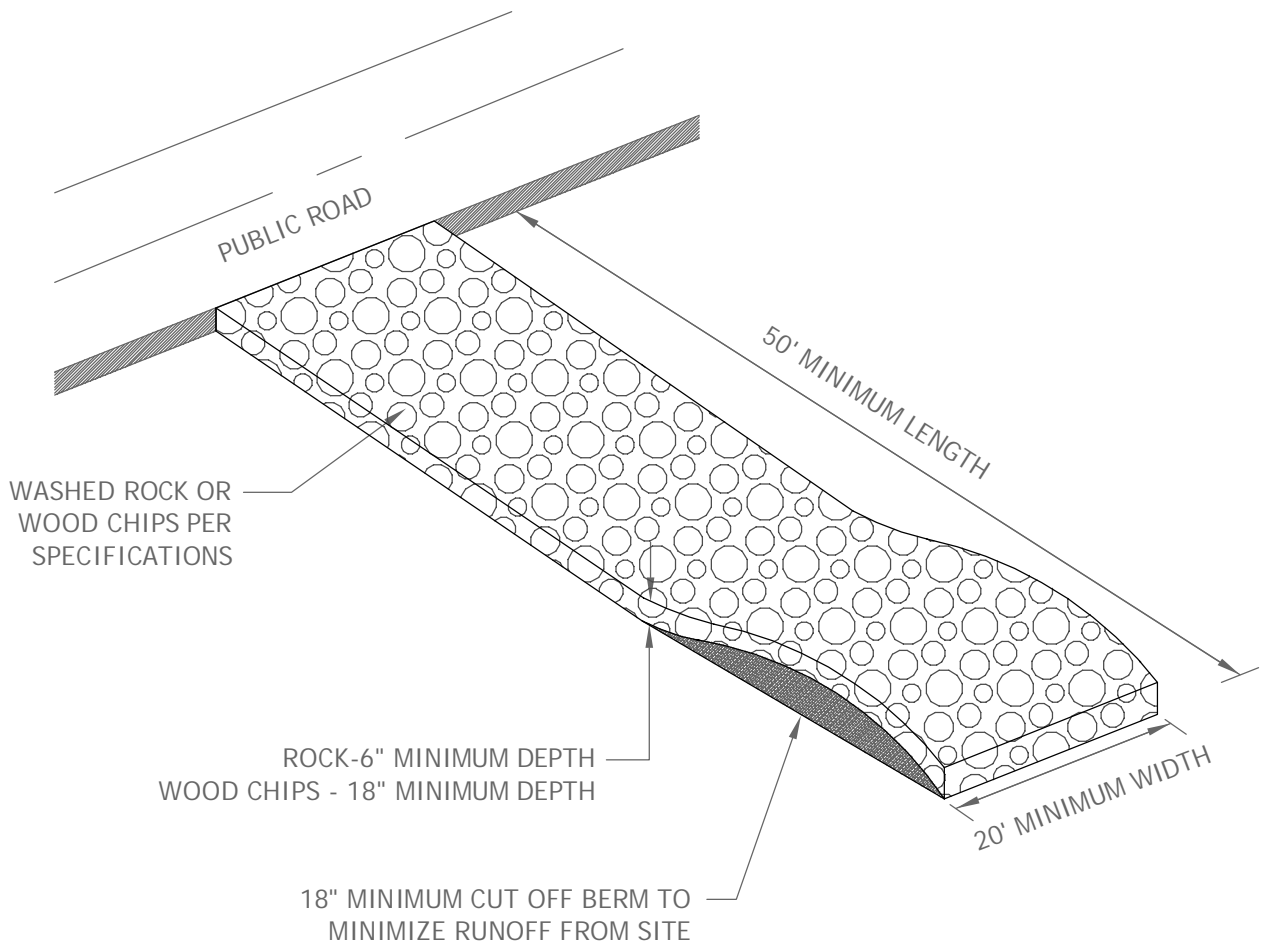

**NOTES:**

1. FILTER FABRIC SHALL BE PLACED UNDER ROCK OR MULCH TO STOP MUD MIGRATION THROUGH ROCK. FILTER FABRIC IS NOT REQUIRED UNDER WOOD CHIPS.
2. 80% OF WOOD CHIPS USED FOR CONSTRUCTION ENTRANCES MUST BE BETWEEN 2 INCHES AND 5 INCHES. NO CHIPPED-UP MANUFACTURED WOOD AND / OR CHEMICALLY TREATED WOOD IS ALLOWED.
3. ENTRANCE MUST BE MAINTAINED REGULARLY TO PREVENT SEDIMENTATION ON PUBLIC ROADWAYS. FUGITIVE ROCK OR WOOD CHIPS WILL BE REMOVED FROM ADJACENT ROADWAYS DAILY OR MORE FREQUENTLY AS NECESSARY.



**STANDARD DETAILS**  
**CONSTRUCTION ENTRANCE**  
**ROCK, WOOD CHIP**

**FRIDLEY, MINNESOTA**

LAST REVISION:  
 DEC 2018

CITY PLATE NO.  
 ERO-7

### I. PLAN VIEW

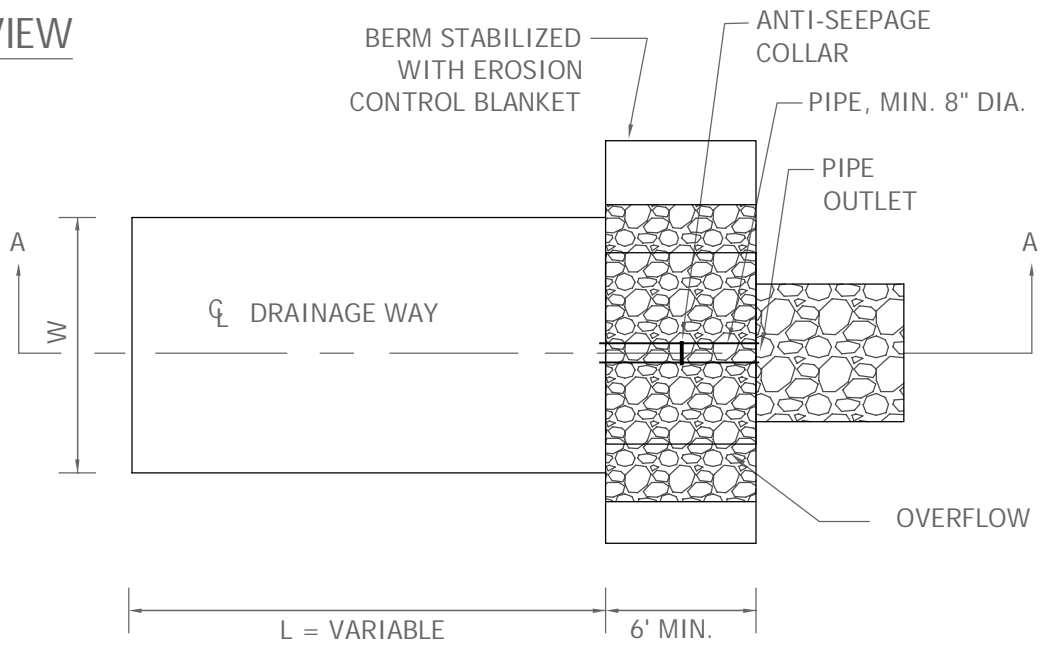

### II. SECTION A-A

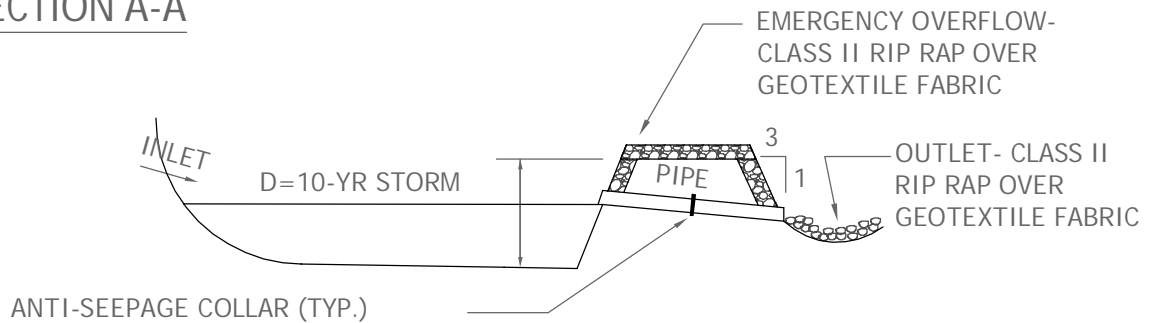

### III. BASIN EMERGENCY OVERFLOW

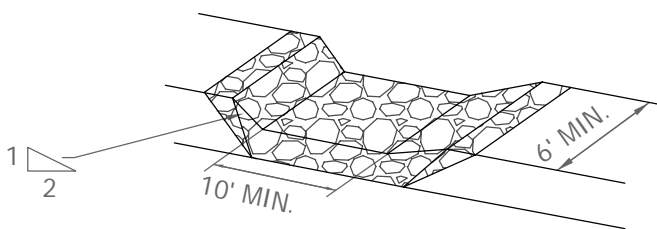

**NOTES:**

BASIN USED FOR 10 ACRES DRAINAGE AREA OR MORE. DESIGN RUNOFF VOLUME IS FROM A 2-YR, 24-HR STORM PER ACRE DRAINED TO THE BASIN. BASIN VOLUME MUST BE A MIN. OF 1800 CUBIC FEET/ACRE. SEE PLANS/SPECIFICATIONS FOR BASIN DIMENSIONS AND PIPE SIZE AND SLOPE.



**STANDARD DETAILS**  
**TEMPORARY SEDIMENTATION BASIN**  
**PIPE OUTLET**

**FRIDLEY, MINNESOTA**

LAST REVISION:  
 DEC 2018

CITY PLATE NO.  
 ERO-8A

# I. PLAN VIEW

**NOTES:**  
 BASIN USED FOR 10 ACRES DRAINAGE AREA OR MORE. DESIGN RUNOFF VOLUME IS FROM A 2-YR, 24-HR STORM PER ACRE DRAINED TO THE BASIN. BASIN VOLUME MUST BE A MIN. OF 1800 CUBIC FEET/ACRE. SEE PLANS/SPECIFICATIONS FOR BASIN DIMENSIONS AND PIPE SIZE AND SLOPE.

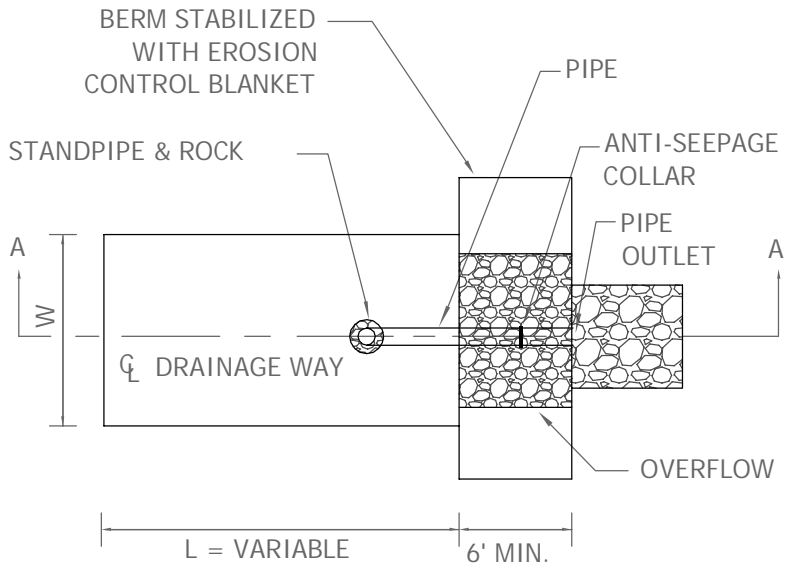

# II. SECTION A-A

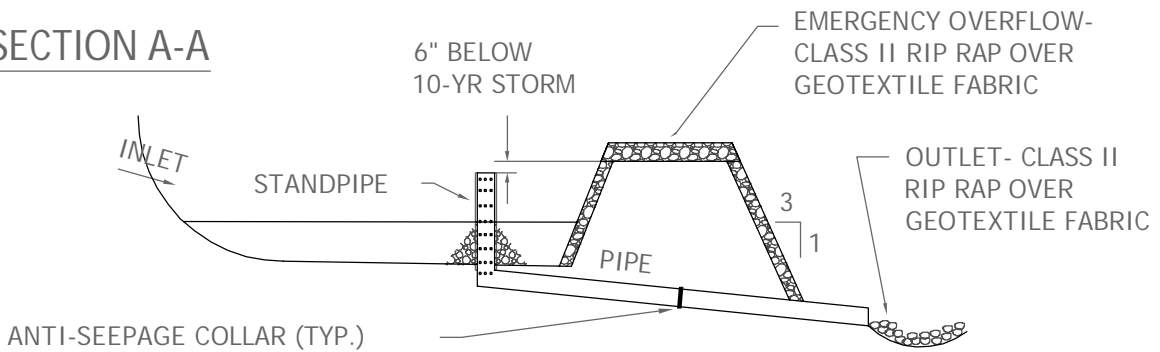

# III. BASIN STANDPIPE AND EMERGENCY OVERFLOW

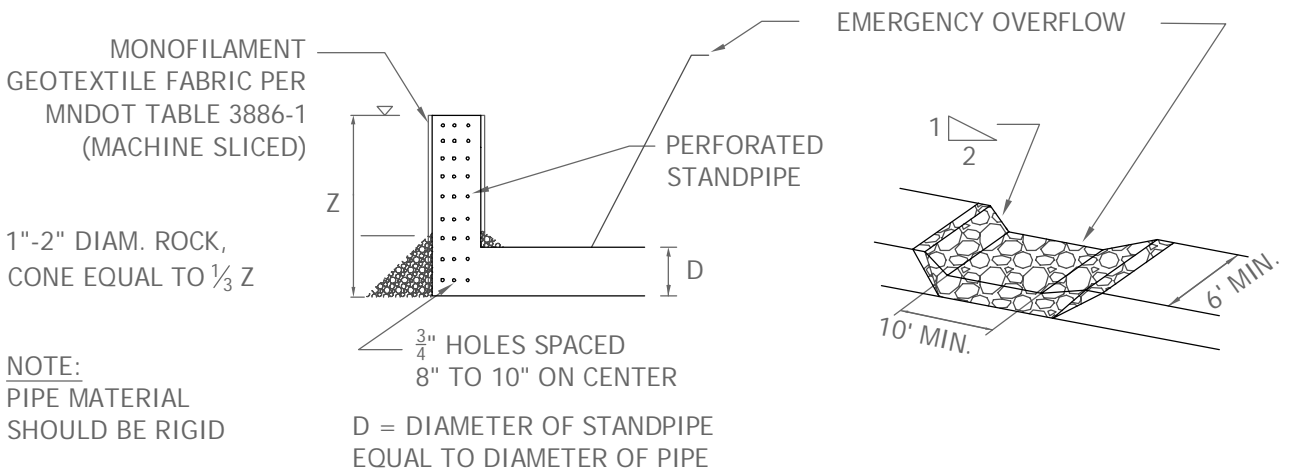

**NOTE:**  
 PIPE MATERIAL SHOULD BE RIGID

D = DIAMETER OF STANDPIPE  
 EQUAL TO DIAMETER OF PIPE



**STANDARD DETAILS**  
 TEMPORARY SEDIMENTATION BASIN  
 STANDPIPE OUTLET

**FRIDLEY, MINNESOTA**

LAST REVISION:  
 DEC 2018

CITY PLATE NO.  
 ERO-8B

# I. PLAN VIEW

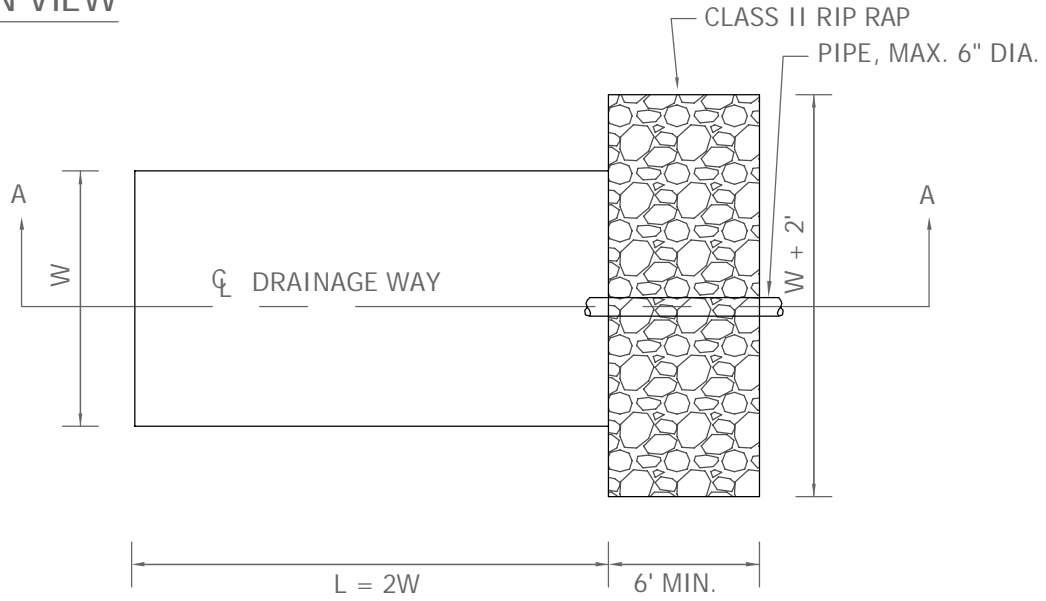

# II. SECTION A-A

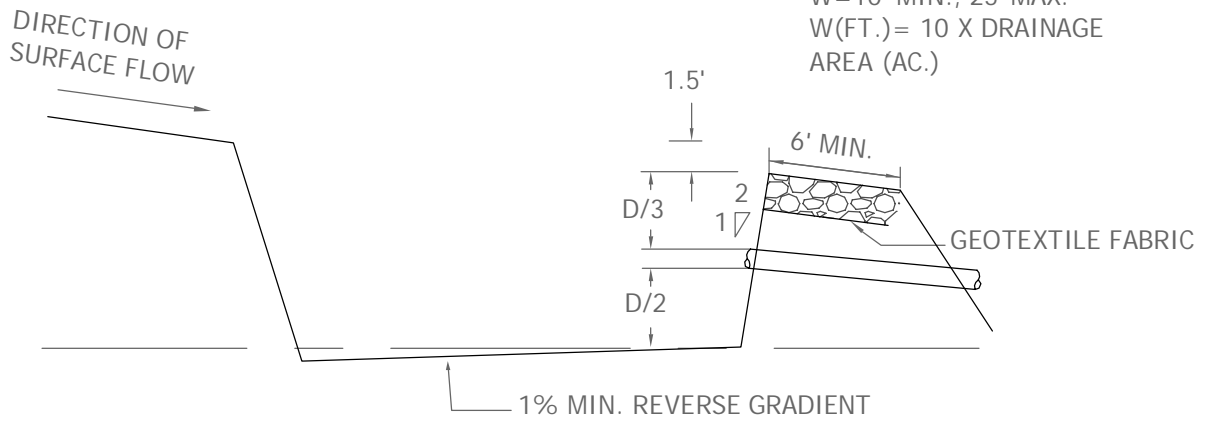

STANDARD DETAILS  
 TEMPORARY SEDIMENT TRAP  
 FRIDLEY, MINNESOTA

LAST REVISION:  
 DEC 2018

CITY PLATE NO.  
 ERO-9



## PROFILE VIEW

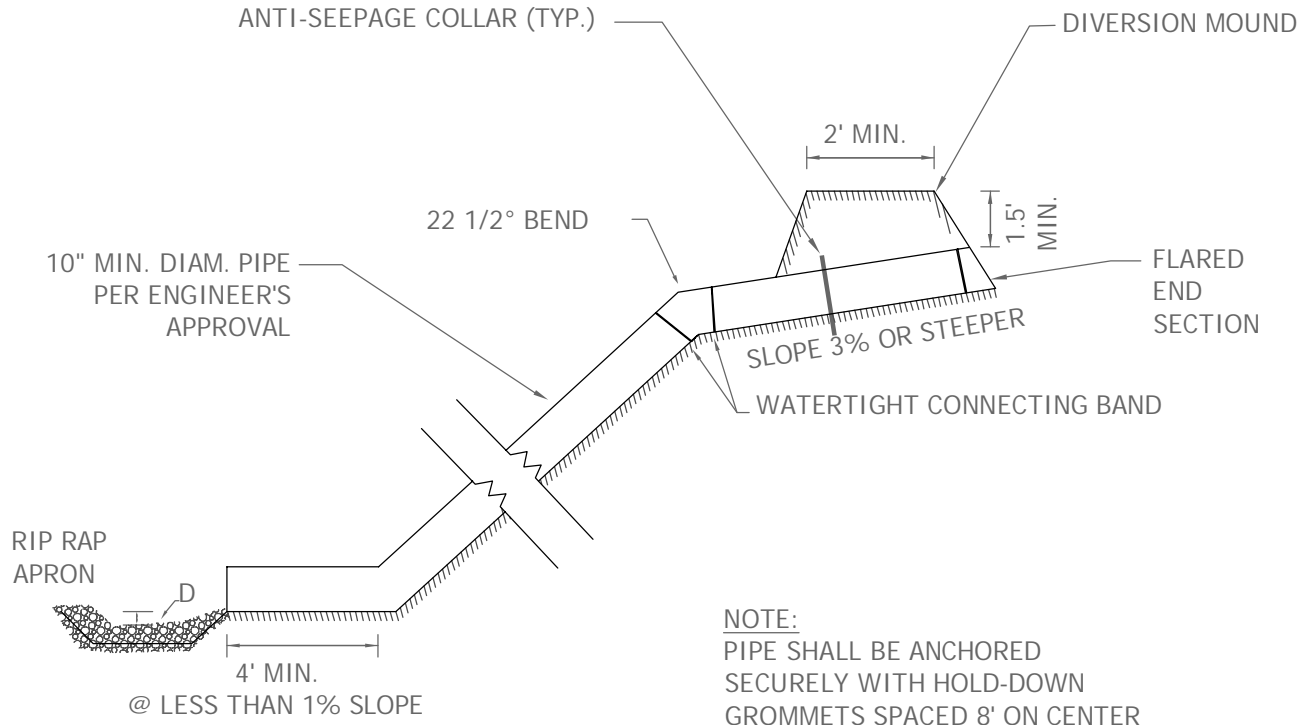

## RIP RAP APRON PLAN

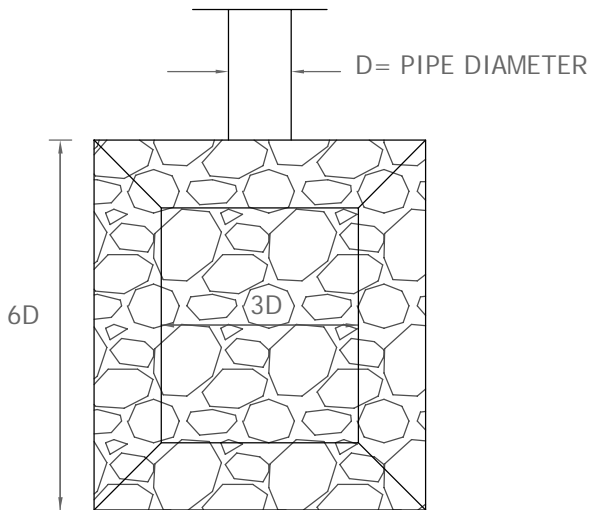

## PLAN VIEW

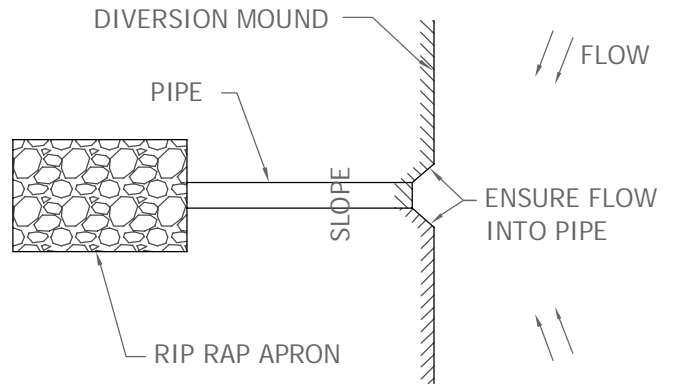

## STANDARD DETAILS DIVERSION MOUND AND TEMPORARY PIPE DOWNDRAIN

# FRIDLEY, MINNESOTA

LAST REVISION:  
DEC 2018

CITY PLATE NO.  
ERO-10

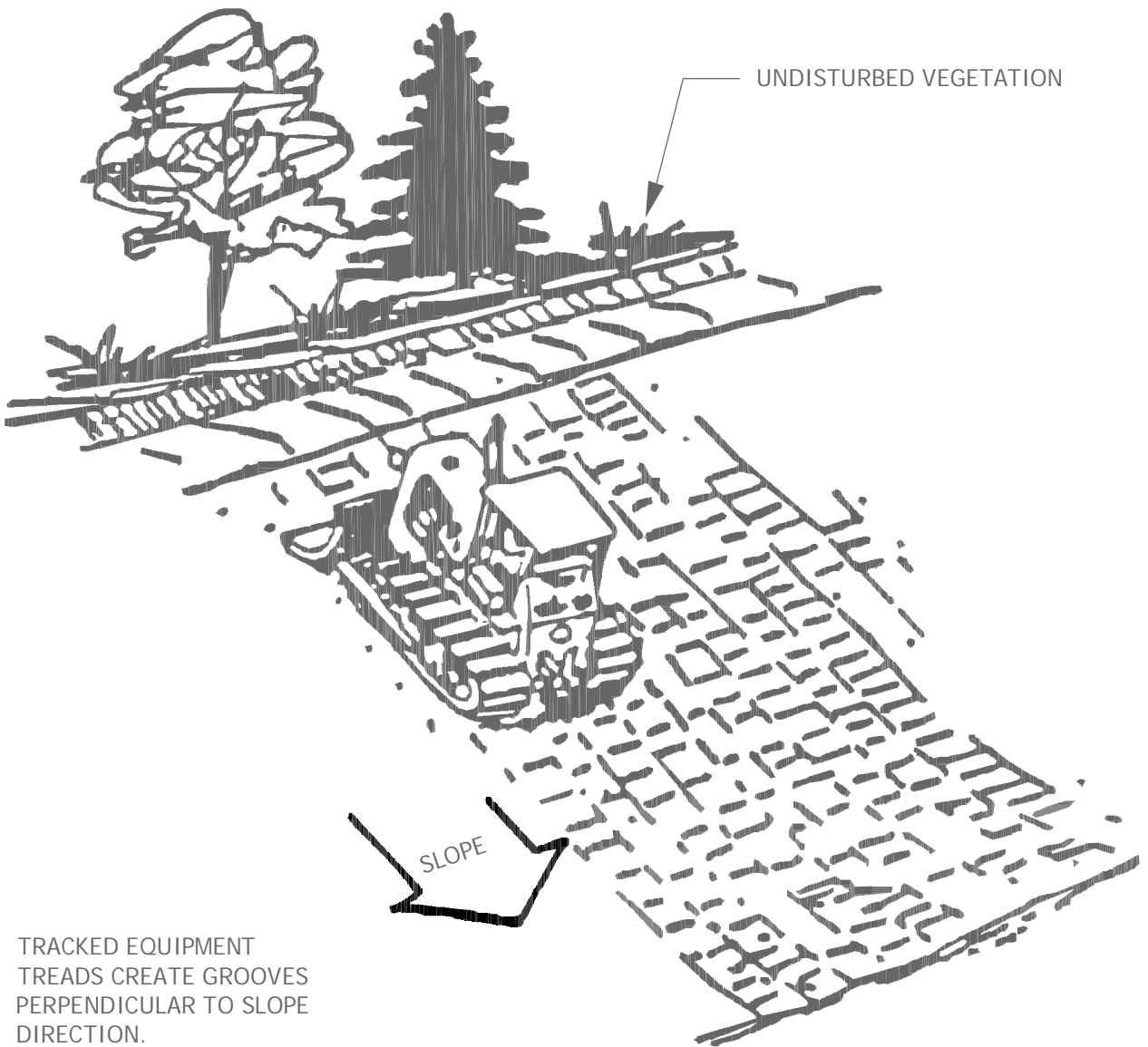

TRACKED EQUIPMENT  
TRENDS CREATE GROOVES  
PERPENDICULAR TO SLOPE  
DIRECTION.

NOTE:  
ALL SLOPES WITH A GRADE EQUAL TO OR STEEPER THAN 3:1  
REQUIRE SLOPE TRACKING. SLOPES WITH A GRADE MORE GRADUAL  
THAN 3:1 REQUIRE SLOPE TRACKING IF THE STABILIZATION METHOD  
IS EROSION CONTROL BLANKET OR HYDROMULCH.



STANDARD DETAILS

SLOPE TRACKING

FRIDLEY, MINNESOTA

LAST REVISION:  
DEC 2018

CITY PLATE NO.  
ERO-11

**PROFILE VIEW**

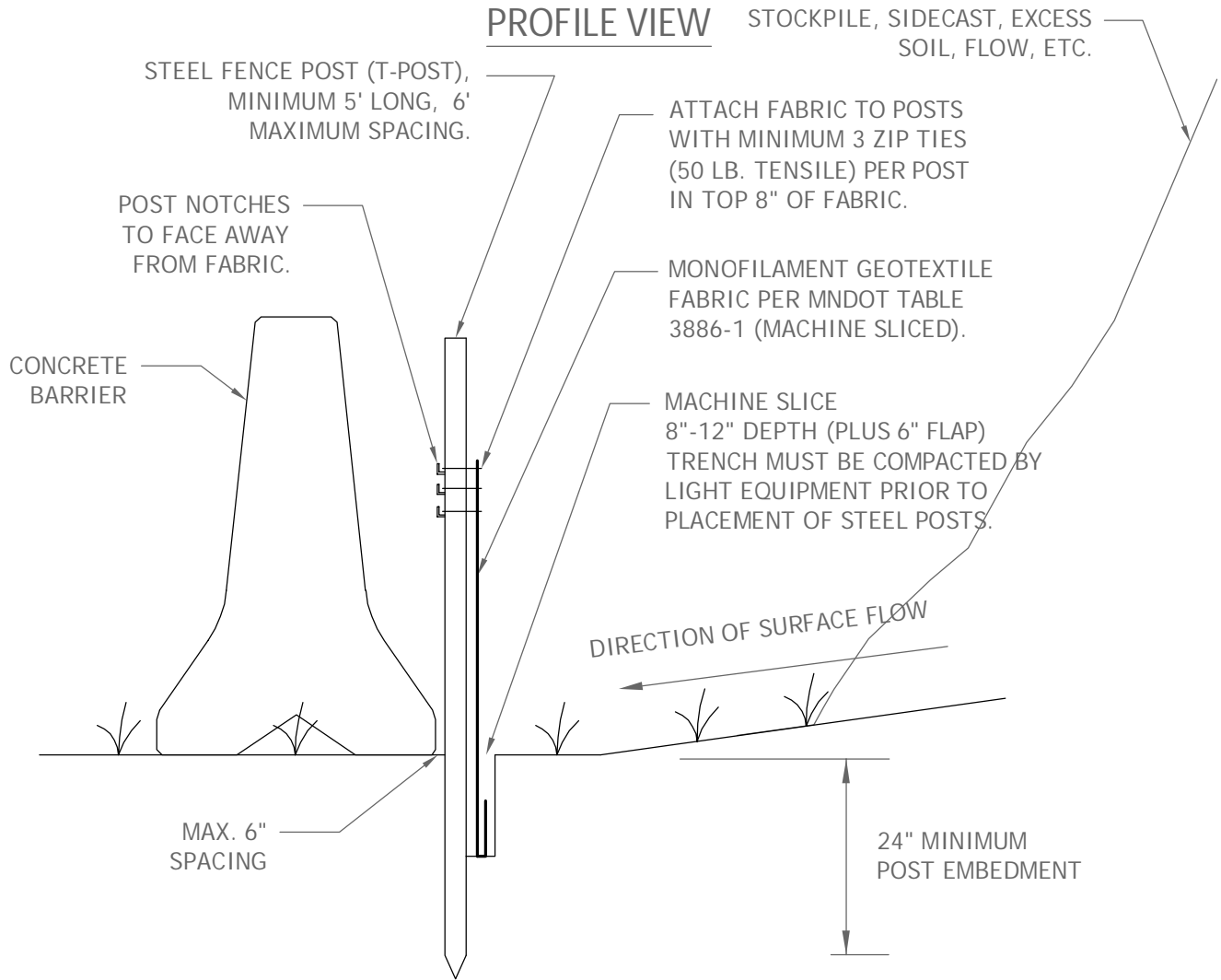

**NOTE:**

1. INSTALL SILT FENCE USING MACHINE-SLICED METHOD.
2. PLACE BARRIER ON FLAT SURFACE (PREP IF NECESSARY).

**PLAN VIEW**

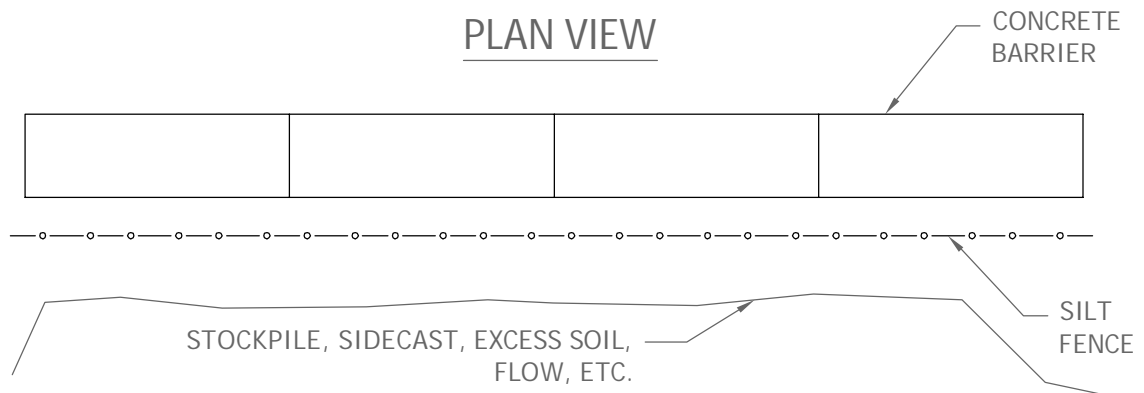

**STANDARD DETAILS**  
**SUPER DUTY PERIMETER CONTROL**  
**SILT FENCE/CONCRETE BARRIER SYSTEM**

**FRIDLEY, MINNESOTA**

LAST REVISION:  
 DEC 2018

CITY PLATE NO.  
 ERO-12A

# PROFILE VIEW

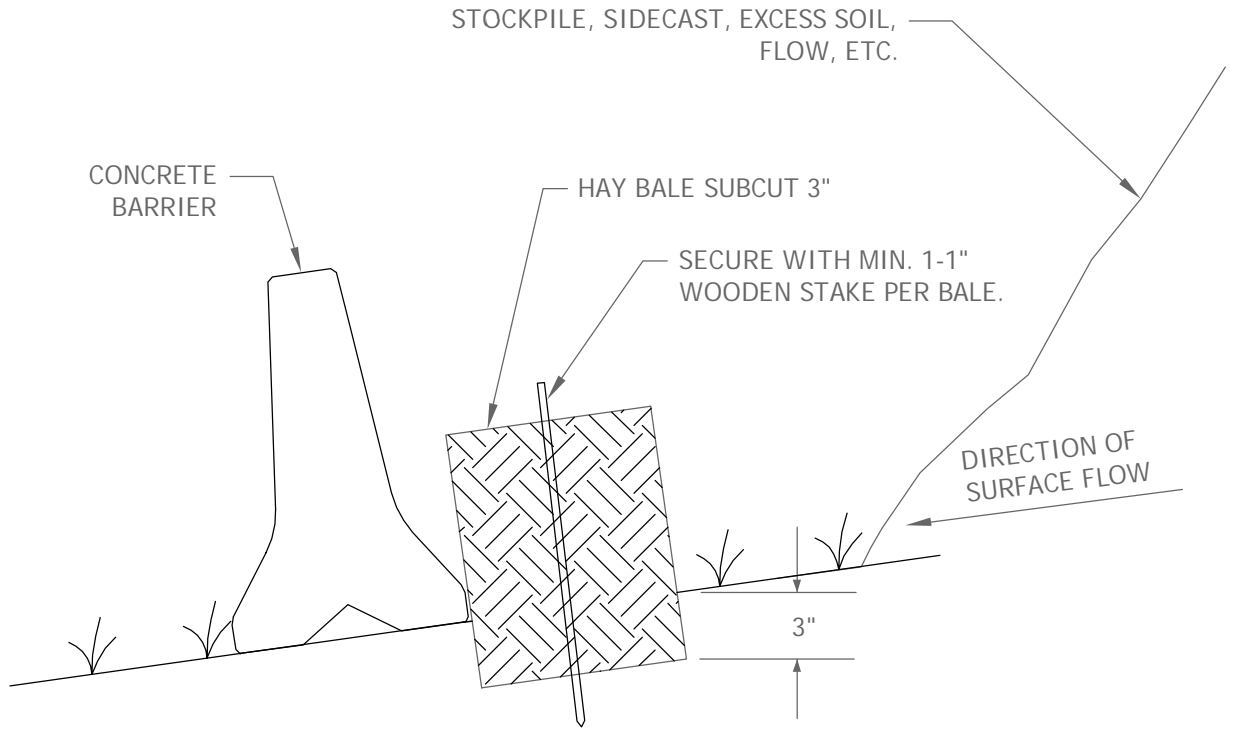

NOTE:  
PLACE BARRIER ON FLAT SURFACE (PREP IF NECESSARY)

# PLAN VIEW

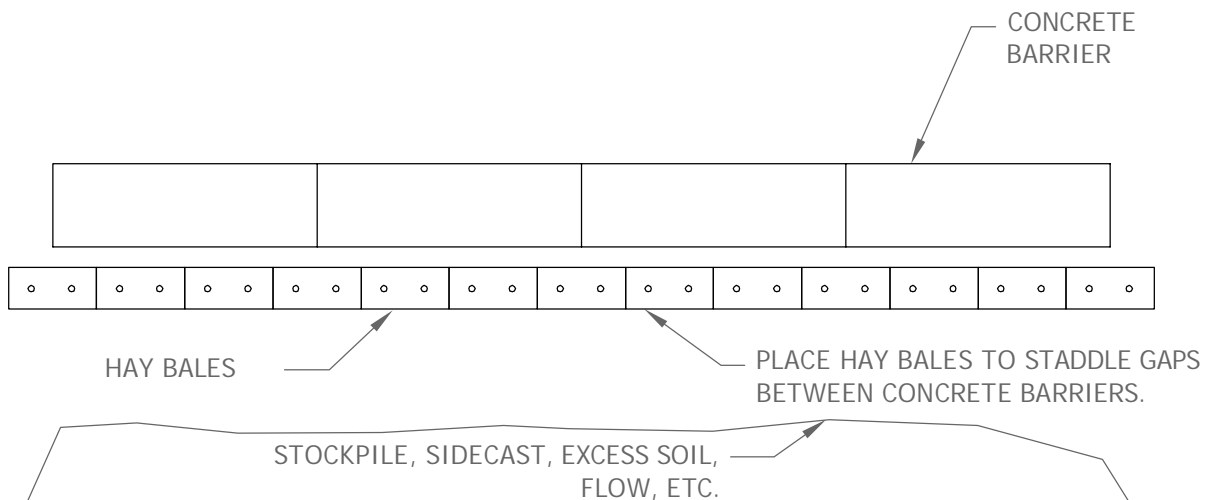

STANDARD DETAILS  
SUPER DUTY PERIMETER CONTROL  
HALE BALE/CONCRETE BARRIER SYSTEM

FRIDLEY, MINNESOTA

LAST REVISION:  
DEC 2018

CITY PLATE NO.  
ERO-12B

## PROFILE VIEW-UPLAND PERIMETER CONTROL

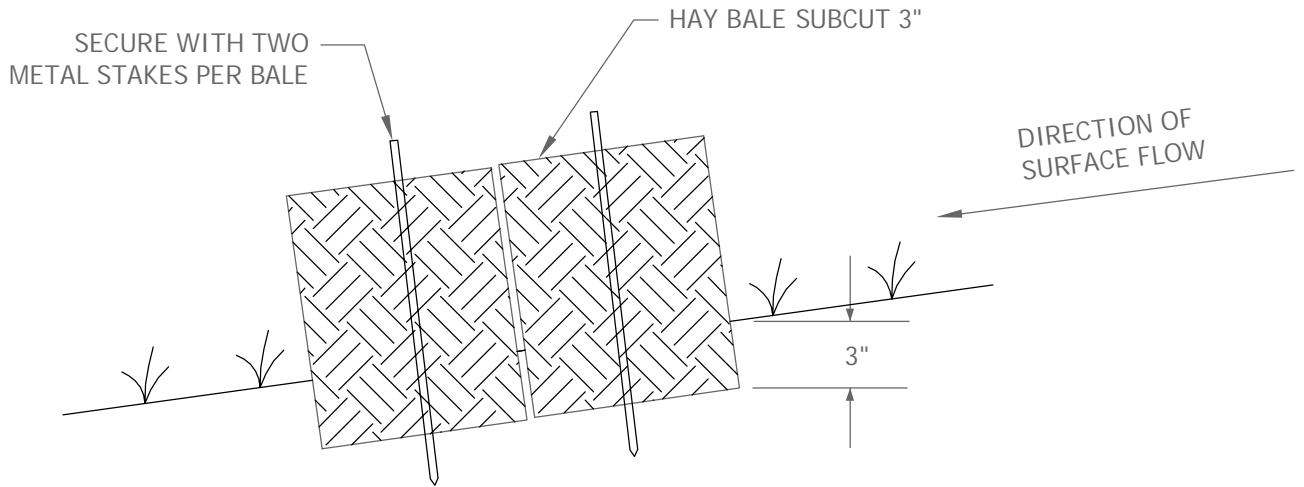

## PROFILE VIEW-PERIMETER CONTROL IN SHALLOW STANDING WATER

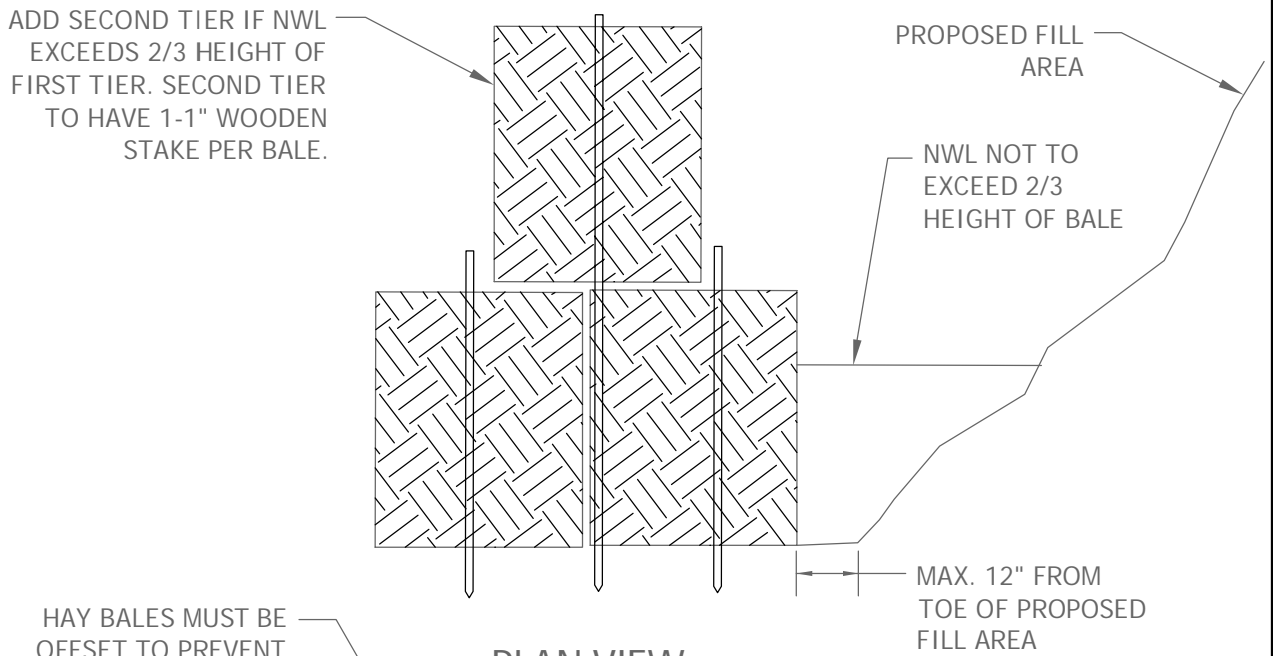

### PLAN VIEW

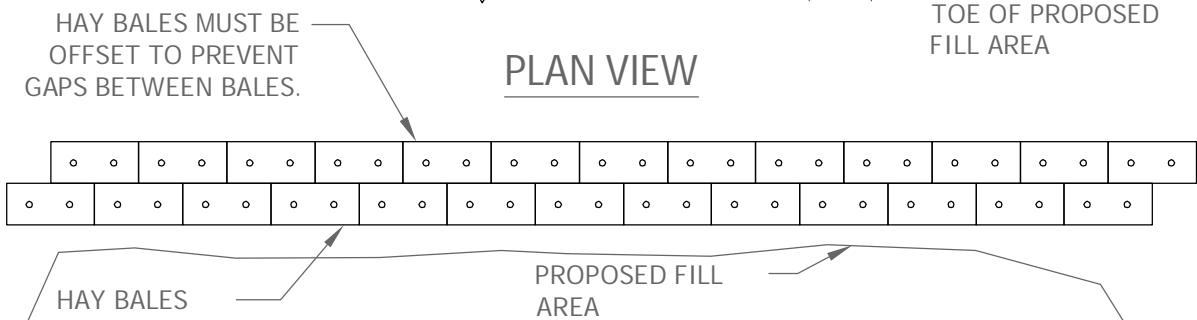

### STANDARD DETAILS PERIMETER / SEDIMENT CONTROL HAY BALES

## FRIDLEY, MINNESOTA

LAST REVISION:  
DEC 2018

CITY PLATE NO.  
ERO-12C

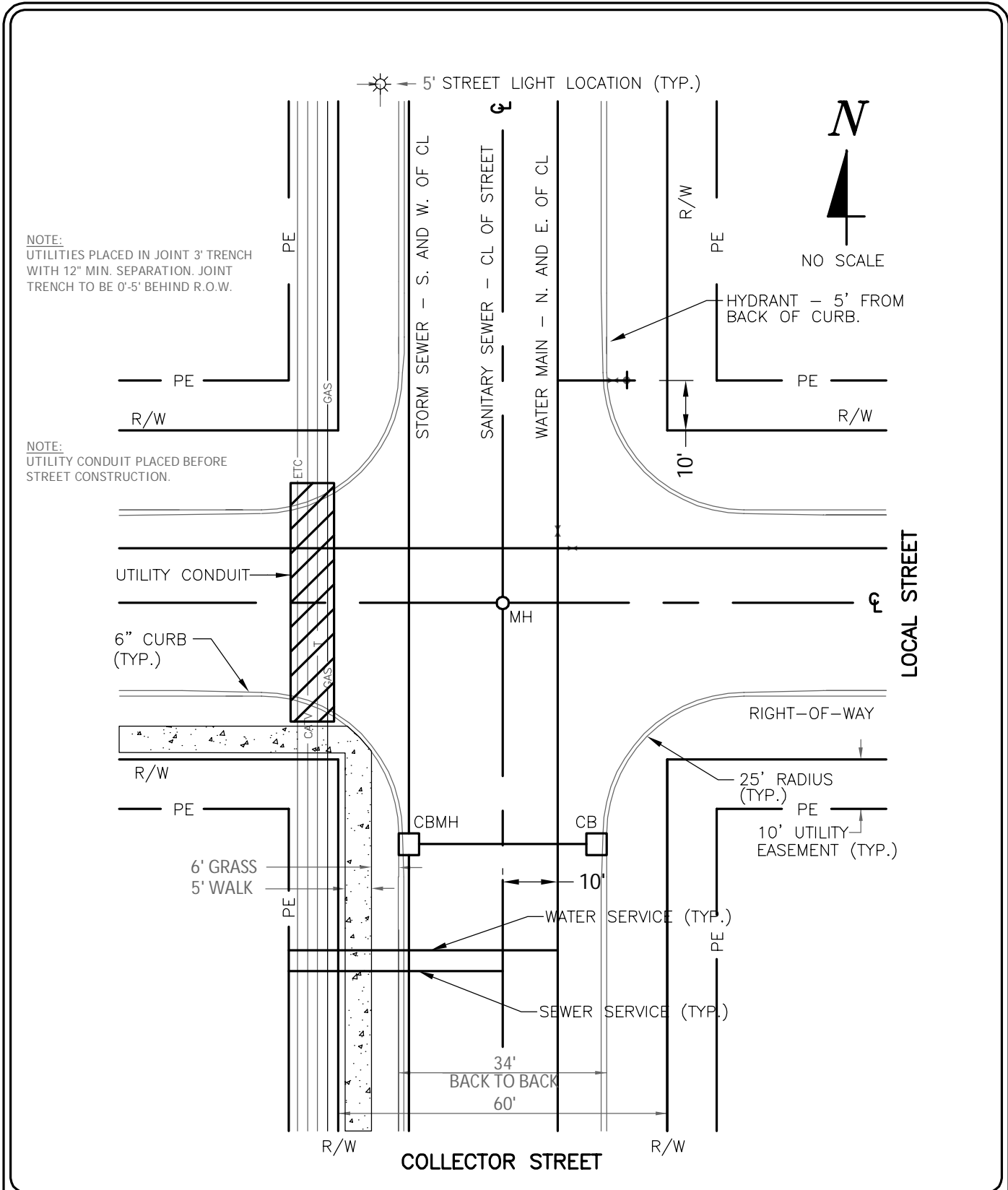

**STANDARD DETAILS**  
**TYPICAL UTILITY LOCATIONS**  
**(PUBLIC AND PRIVATE)**  
**FRIDLEY, MINNESOTA**

LAST REVISION:  
DEC 2018

CITY PLATE NO.  
GEN-1

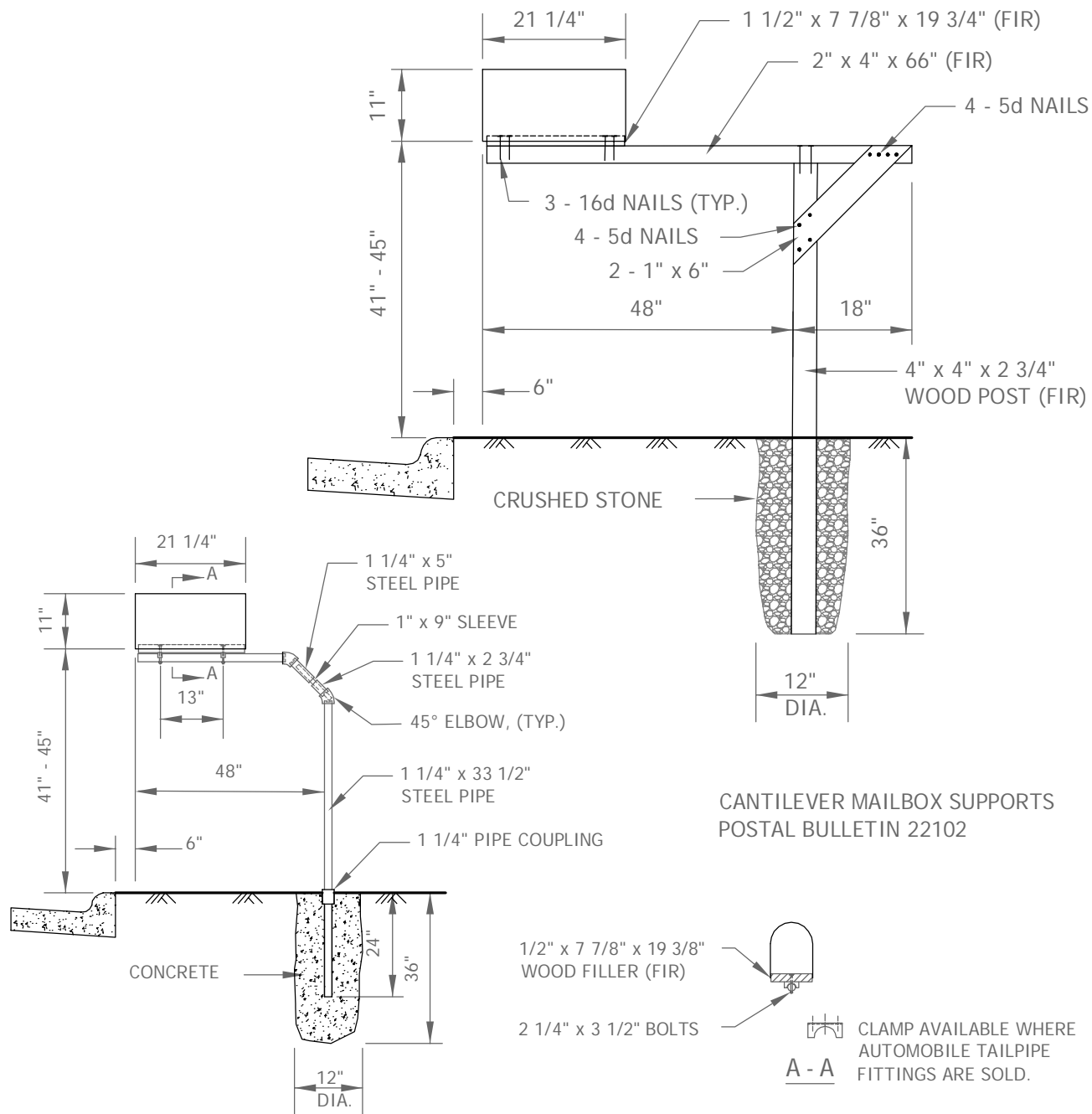

**NOTES:**

1. MAILBOX SHOULD NOT EXTEND BEYOND THE BACK OF CURB.
2. ADDRESS MUST BE ON SIDE OF MAILBOX FROM WHICH CARRIER APPROACHES IN LETTERS ABOUT 1" HIGH (OR ON FRONT WHEN MAILBOXES ARE GROUPED).
3. MAILBOXES MUST BE LOCATED SO CARRIER CAN SERVE WITHOUT LEAVING VEHICLE.
4. MAILBOXES WITHIN CUL-DE-SACS SHALL BE PLACED ON THE STRAIGHT AWAY ONLY.
5. SUPPORTS COMPRISED OF MATERIALS OTHER THAN SOLELY WOOD OR METAL (SUCH AS BRICK STRUCTURE, ETC. SHALL NOT BE ALLOWED).



**STANDARD DETAILS**

**MAILBOX INSTALLATION**

**FRIDLEY, MINNESOTA**

LAST REVISION:  
DEC 2018

CITY PLATE NO.  
GEN-2

HEIGHT - 48" ABOVE STREET LEVEL

HAVE MAILBOX EXTEND AS FAR IN FRONT OF SUPPORT POST AS POSSIBLE. (THIS PREVENTS POSSIBLE SNOW PLOW DAMAGE).

ADDRESS MUST BE ON SIDE OF MAILBOX FROM WHICH CARRIER APPROACHES IN LETTERS ABOUT 1" HIGH. (OR ON FRONT WHERE MAILBOXES ARE GROUPED).

MAILBOX MUST BE LOCATED SO CARRIER CAN SERVE WITHOUT LEAVING VEHICLE.

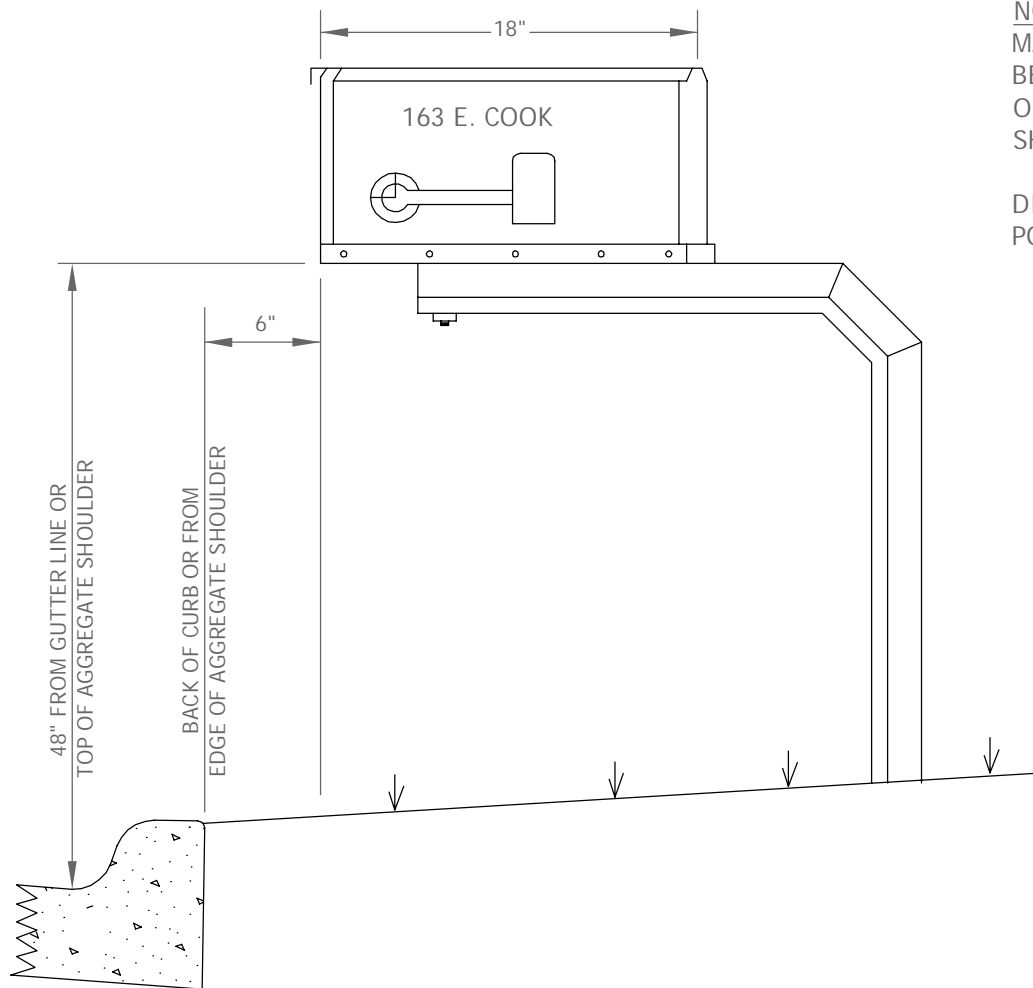

NOTES:  
MAILBOX SHOULD BE 6"  
BEHIND BACK OF CURB  
OR EDGE OF AGGREGATE  
SHOULDER.

DIMENSIONS AS PER U.S.  
POSTAL SERVICE.



STANDARD DETAILS  
MAILBOX INSTALLATION

FRIDLEY, MINNESOTA

LAST REVISION:  
DEC 2018

CITY PLATE NO.  
GEN-2A



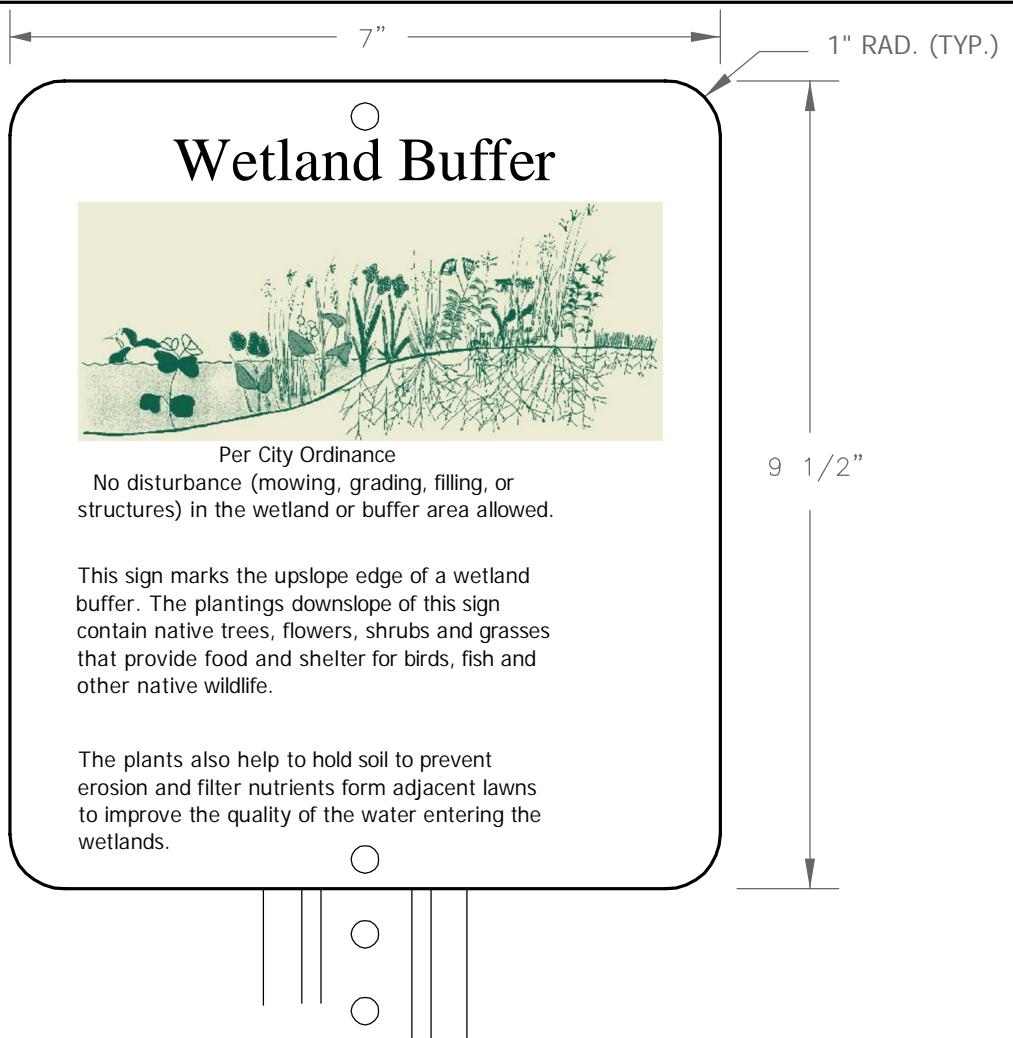

1. THE SIGN MUST BE:
  - a. 0.063 ALUMINUM BLANK,
  - b. BACKGROUND PANTONE: 155 (TAN)
  - c. BLACK VERBIAGE AND LOGO PRINTED ONE SIDE
  - d. PRE-DRILL HOLES IN MIDDLE TOP AND BOTTOM (AVOID VERBIAGE)
  - e. TRIM TO BORDER AS SHOWN ON SIGN ARTWORK TO INSURE ROUNDED CORNERS
2. THE MARKER SHALL CONSIST OF A FOUR INCH SQUARE TREATED, OR CEDAR POST, OR GREEN STEEL POST INSTALLED TO A HEIGHT OF FOUR FEET ABOVE GRADE, AND SET AT LEAST 42" INTO GROUND.
3. BOLT OR SCREW SIGN TO POST.
4. ONE SIGN SHALL BE PLACED PER LOT AT THE UPSLOPE EDGE OF THE REQUIRED BUFFER STRIP FOR THE WETLAND. PROPOSED LOCATIONS OF SIGNS SHALL BE SHOWN GRADING OR SITE PLAN. IN GENERAL, THE LOCATION OF SIGNS SHALL CAPTURE THE PORTION OF THE BUFFER THAT EXTENDS THE FURTHEST UPSLOPE INTO THE LOT. A PLAN THAT SHOWS THE LOCATION OF THE SIGN SHALL BE PROVIDED TO THE CITY ENGINEER FOR REVIEW AND APPROVAL.
5. ARTWORK AND VERBIAGE SHALL FACE PROPOSED HOME (STRUCTURE).
6. CONTACT CITY FOR POTENTIAL SIGN SOURCES.



### STANDARD DETAILS

WETLAND BUFFER SIGN

**FRIDLEY, MINNESOTA**

LAST REVISION:  
DEC 2018

CITY PLATE NO.  
GEN-3

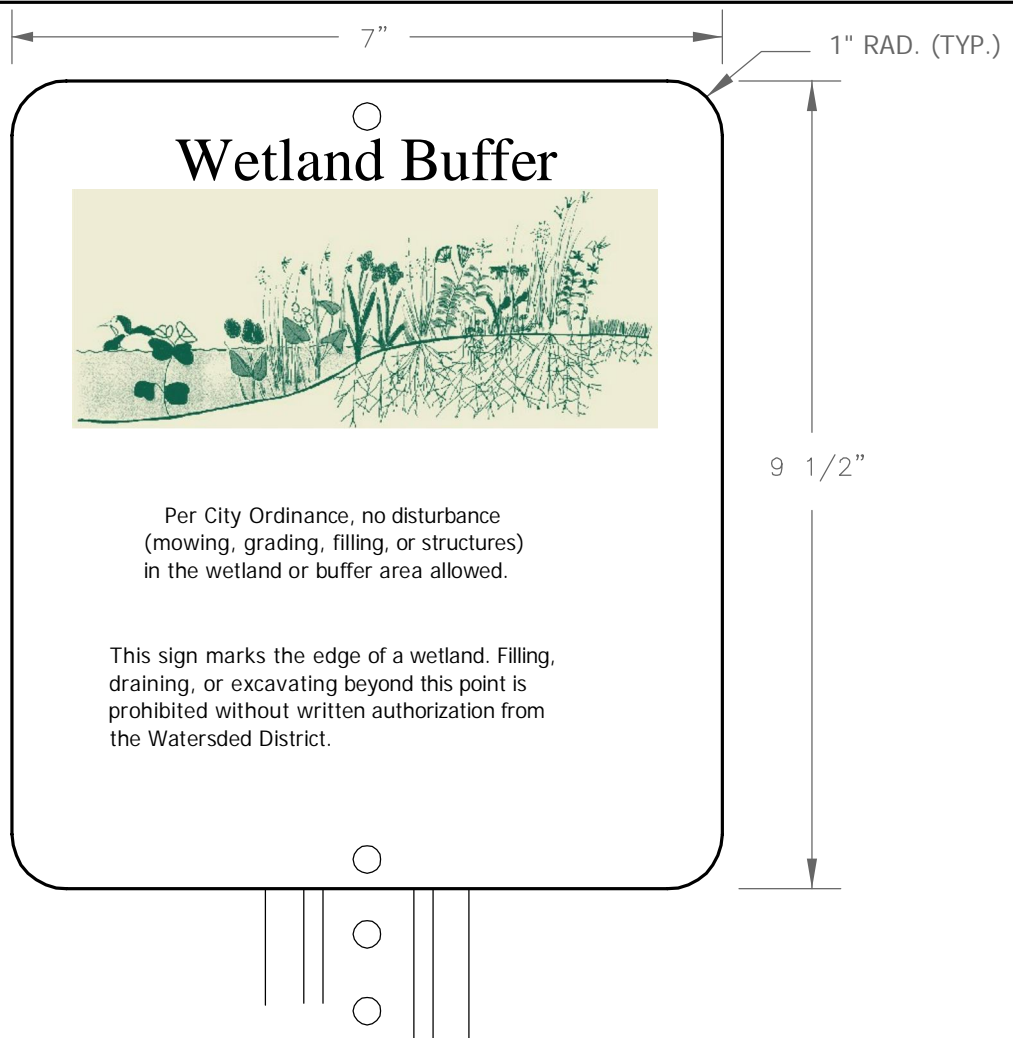

1. THE SIGN MUST BE:
  - a. 0.063 ALUMINUM BLANK,
  - b. BACKGROUND PANTONE: 155 (TAN)
  - c. BLACK VERBIAGE AND LOGO PRINTED ONE SIDE
  - d. PRE-DRILL HOLES IN MIDDLE TOP AND BOTTOM (AVOID VERBIAGE)
  - e. TRIM TO BORDER AS SHOWN ON SIGN ARTWORK TO INSURE ROUNDED CORNERS
2. THE MARKER SHALL CONSIST OF A FOUR INCH SQUARE TREATED, OR CEDAR POST, OR GREEN STEEL POST INSTALLED TO A HEIGHT OF FOUR FEET ABOVE GRADE, AND SET AT LEAST 42" INTO GROUND.
3. BOLT OR SCREW SIGN TO POST.
4. ONE SIGN SHALL BE PLACED PER LOT AT THE UPSLOPE EDGE OF THE REQUIRED BUFFER STRIP FOR THE WETLAND. PROPOSED LOCATIONS OF SIGNS SHALL BE SHOWN GRADING OR SITE PLAN. IN GENERAL, THE LOCATION OF SIGNS SHALL CAPTURE THE PORTION OF THE BUFFER THAT EXTENDS THE FURTHEST UPSLOPE INTO THE LOT. A PLAN THAT SHOWS THE LOCATION OF THE SIGN SHALL BE PROVIDED TO THE CITY ENGINEER FOR REVIEW AND APPROVAL.
5. ARTWORK AND VERBIAGE SHALL FACE PROPOSED HOME (STRUCTURE).
6. CONTACT CITY FOR POTENTIAL SIGN SOURCES.



### STANDARD DETAILS

WETLAND BUFFER SIGN

**FRIDLEY, MINNESOTA**

LAST REVISION:  
DEC 2018

CITY PLATE NO.  
GEN-4

NOTE:  
INSTALL STRUCTURE MARKERS AT ALL  
GREEN SPACE STRUCTURE LOCATIONS

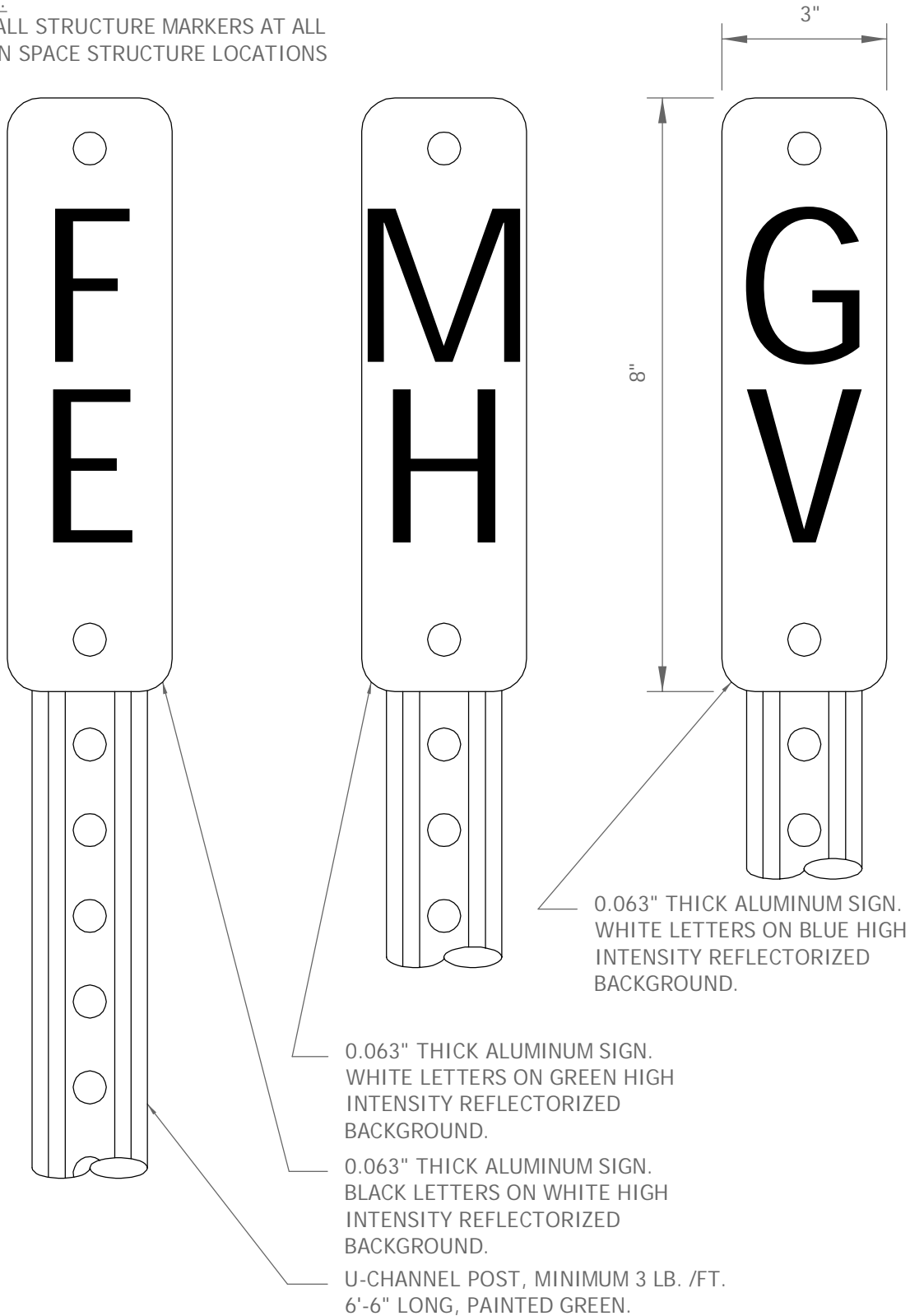

STANDARD DETAILS  
STRUCTURE MARKER SIGNS

FRIDLEY, MINNESOTA

LAST REVISION:  
DEC 2018

CITY PLATE NO.  
GEN-5

PRECAST INVERT MUST BE 1/2  
DIAMETER OF THE PIPE AND BENCHES  
SLOPED 2" TOWARD THE INVERT.

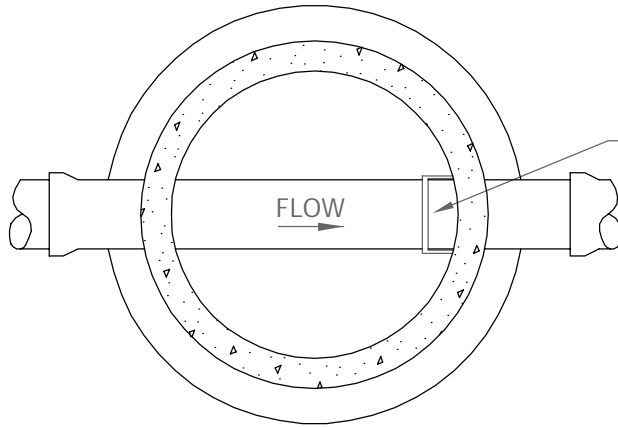

PLAN

MANHOLE STEPS SHALL BE PLACED  
SO THAT OFFSET VERTICAL PORTION  
OF CONE IS FACING DOWNSTREAM.

CASTING AND ADJUSTMENT  
RINGS AS SPECIFIED.

ALL JOINTS IN MANHOLE TO HAVE  
"O" RING RUBBER GASKETS.

WRAP EACH MANHOLE BARREL JOINT  
WITH 12" MASTIC SEAL, OR RING  
JOINTS W/ 3/4" RAM - NEK  
BITUMINOUS ROPE.

PRECAST INVERT REQUIRED.

PIPE SHALL BE CUT OUT FLUSH WITH  
INSIDE FACE OF WALL.

NOTE: KOR-N-SEAL MANHOLE OR EQUAL  
CONSIDERED ACCEPTABLE ALTERNATE.

ALL DOG HOUSES SHALL BE GROUTED  
ON INSIDE AND OUTSIDE.

MINIMUM THICKNESS OF PRECAST BASE IS  
6" FOR 14' DEEP OR LESS, AND INCREASES  
1" IN THICKNESS FOR EVERY 4' OF DEPTH  
GREATER THAN 14'.

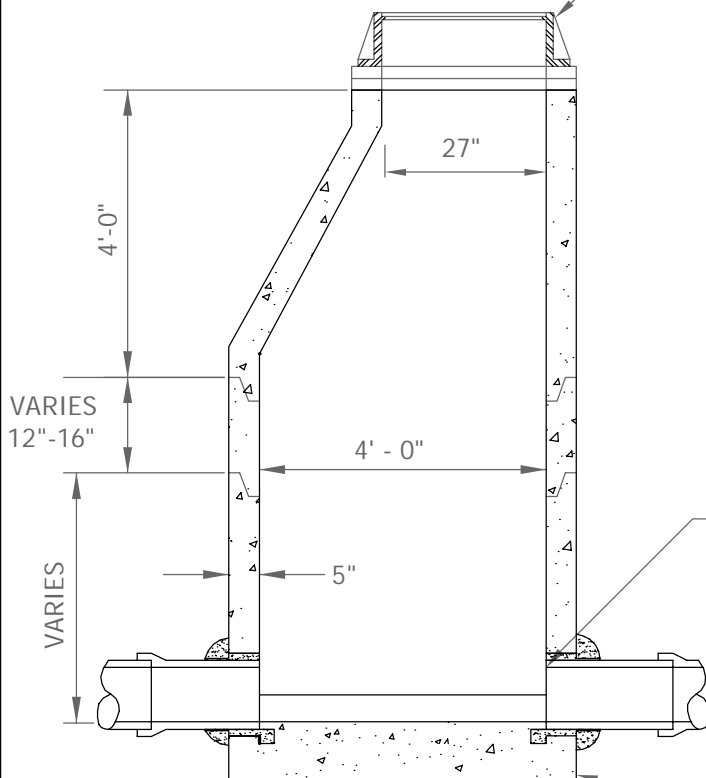

SECTION



STANDARD DETAILS

SANITARY SEWER MANHOLE

FRIDLEY, MINNESOTA

LAST REVISION:  
DEC 2018

CITY PLATE NO.  
SAN-1

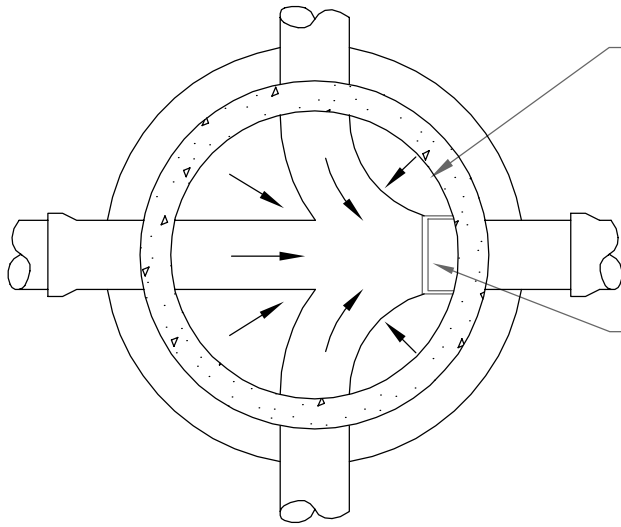

PRECAST INVERT MUST BE 1/2 DIAMETER OF PIPE AND BENCHES SHOULD BE SLOPED 2" TOWARD INVERT.

MANHOLE STEPS SHALL BE PLACED SO THAT OFFSET VERTICAL PORTION OF CONE IS FACING DOWNSTREAM.

PLAN

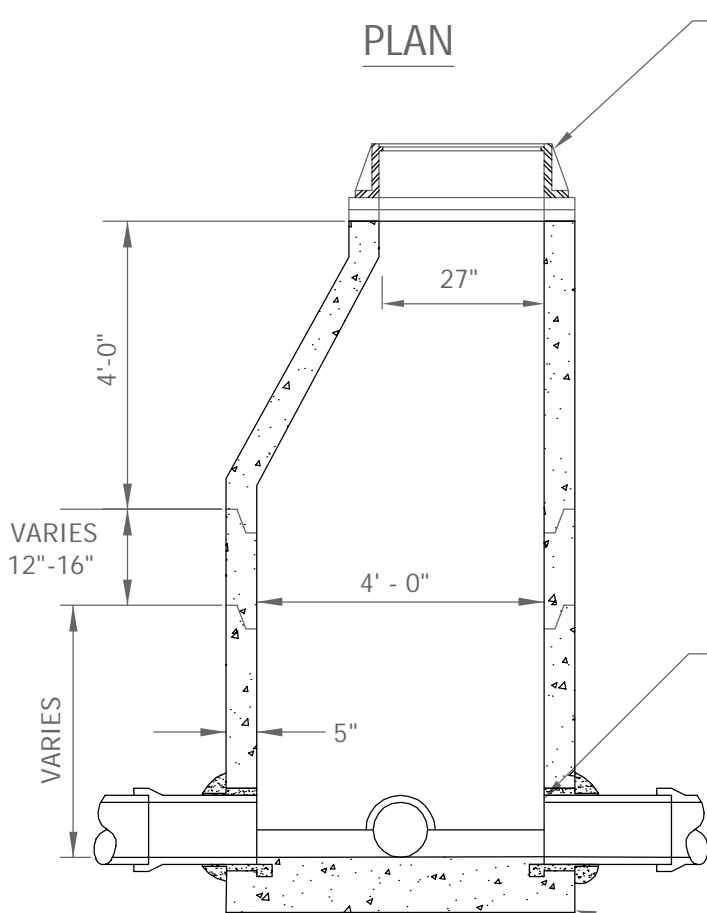

CASTING AND ADJUSTMENT RINGS AS SPECIFIED.

ALL JOINTS IN MANHOLE TO HAVE "O" RING RUBBER GASKETS.

WRAP EACH MANHOLE BARREL JOINT WITH 12" MASTIC SEAL, OR RING JOINTS W/ 3/4" RAM - NEK BITUMINOUS ROPE.

PRECAST INVERT REQUIRED.

PIPE SHALL BE CUT OUT FLUSH WITH INSIDE FACE OF WALL.

NOTE: KOR-N-SEAL MANHOLE OR EQUAL CONSIDERED ACCEPTABLE ALTERNATE.

ALL DOG HOUSES SHALL BE GROUTED ON INSIDE AND OUTSIDE.

MINIMUM THICKNESS OF PRECAST BASE IS 6" FOR 14' DEEP OR LESS, AND INCREASES 1" IN THICKNESS FOR EVERY 4' OF DEPTH GREATER THAN 14'.

SECTION



STANDARD DETAILS  
SANITARY SEWER JUNCTION  
MANHOLE

**FRIDLEY, MINNESOTA**

LAST REVISION:  
DEC 2018

CITY PLATE NO.  
**SAN-2**

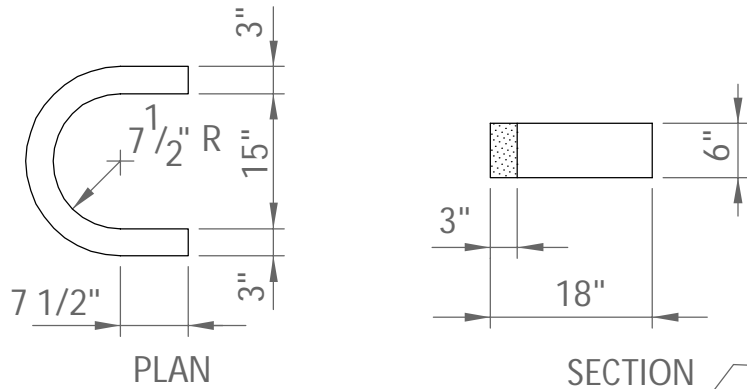

**HORSESHOE DETAILS**

CASTING AND ADJUSTMENT RINGS AS SPECIFIED.

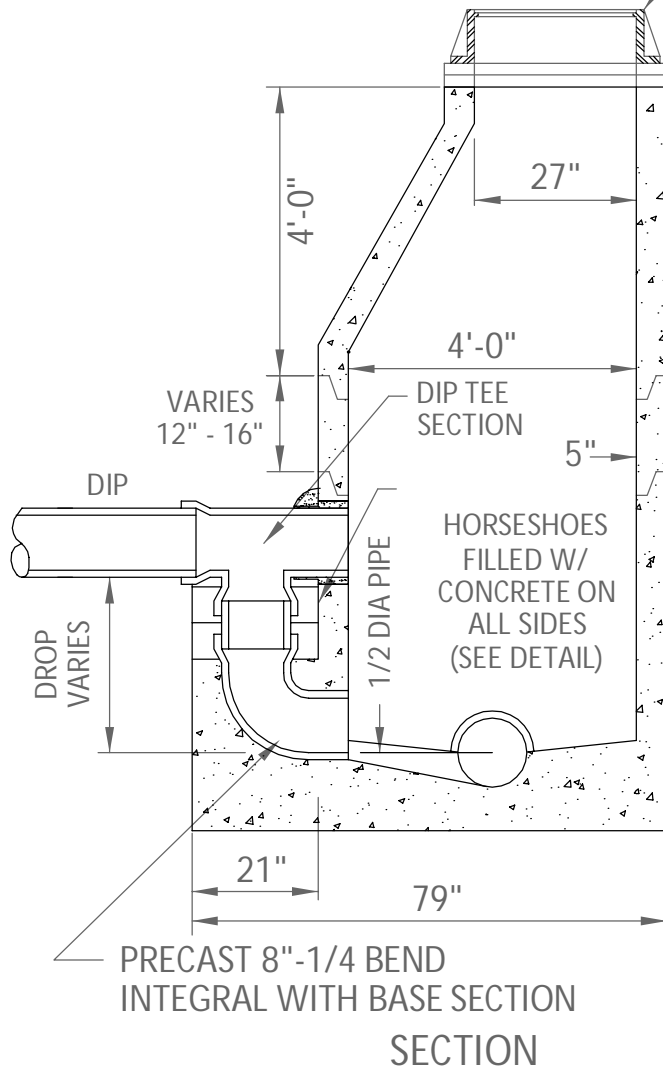

ALL JOINTS IN MANHOLE TO HAVE "O" RING RUBBER GASKETS.

WRAP EACH MANHOLE BARREL JOINT WITH 12" MASTIC SEAL, OR RING JOINTS W/ 3/4" RAM-NEK BITUMINOUS ROPE.

PRECAST INVERT REQUIRED.

PIPE SHALL BE CUT OUT FLUSH WITH INSIDE FACE OF WALL.

NOTE: KOR-N-SEAL MANHOLE OR EQUAL CONSIDERED ACCEPTABLE ALTERNATE.

ALL DOG HOUSES SHALL BE GROUTED ON INSIDE AND OUTSIDE.

PRECAST INVERT SHOULD BE 1/2 DIAMETER OF PIPE AND BENCHES SLOPED 2" TOWARD INVERT.

MINIMUM THICKNESS OF PRECAST BASE IS 6" FOR 14' DEEP OR LESS, AND INCREASES 1" IN THICKNESS FOR EVERY 4' OF DEPTH GREATER THAN 14'.



**STANDARD DETAILS  
SANITARY SEWER DROP INLET  
MANHOLE**

**FRIDLEY, MINNESOTA**

LAST REVISION:  
DEC 2018

CITY PLATE NO.  
SAN-3

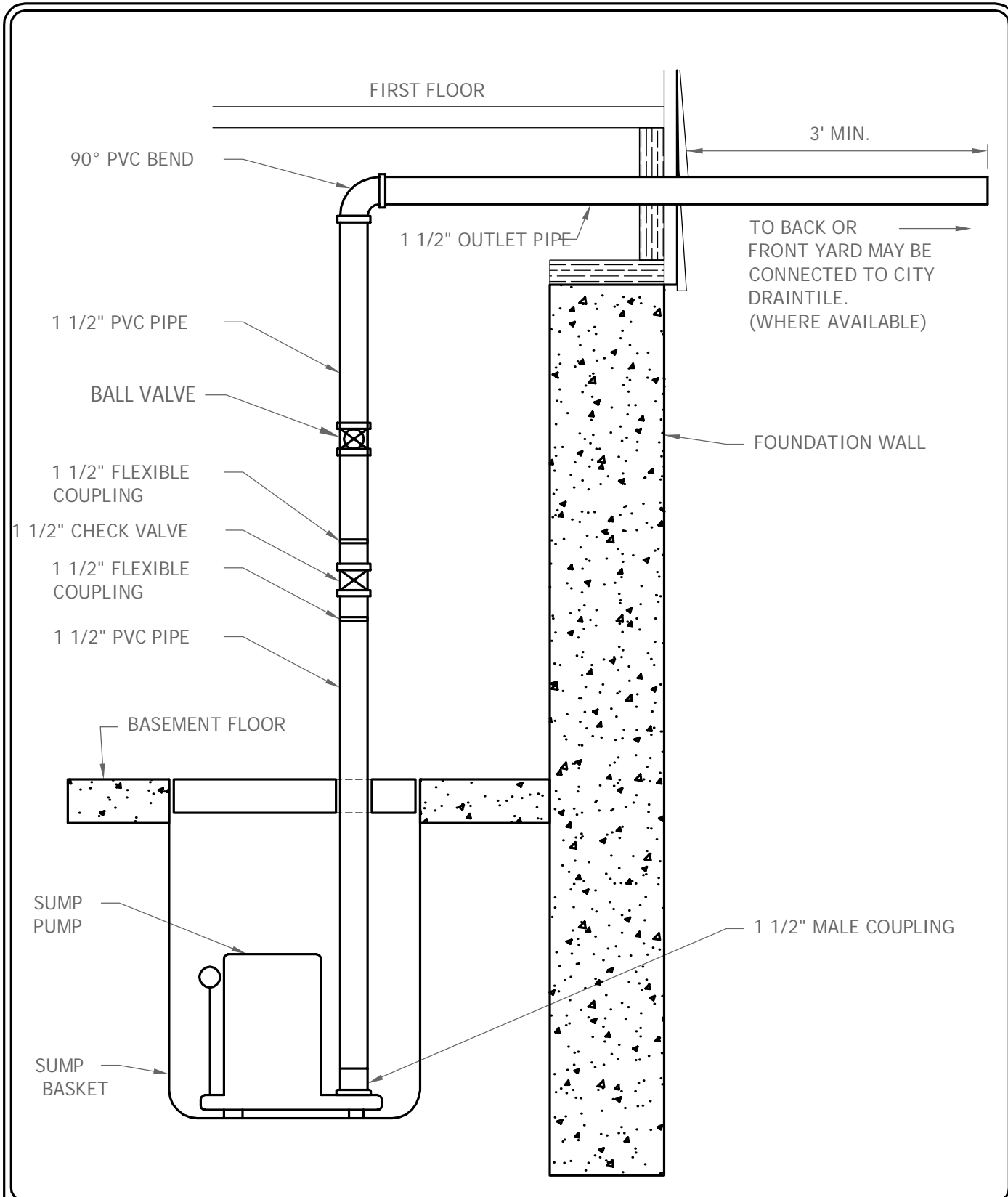

STANDARD DETAILS  
 SUMP PUMP DISCHARGE

FRIDLEY, MINNESOTA

LAST REVISION:  
 DEC 2018

CITY PLATE NO.  
 SAN-420

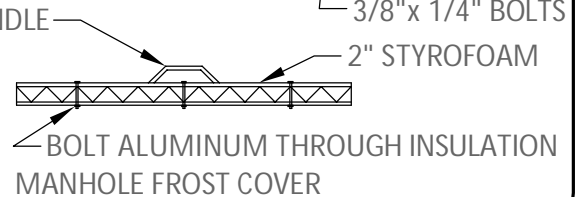
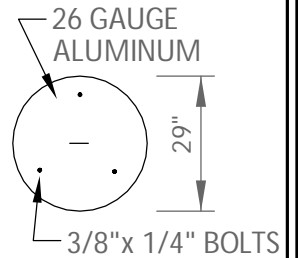
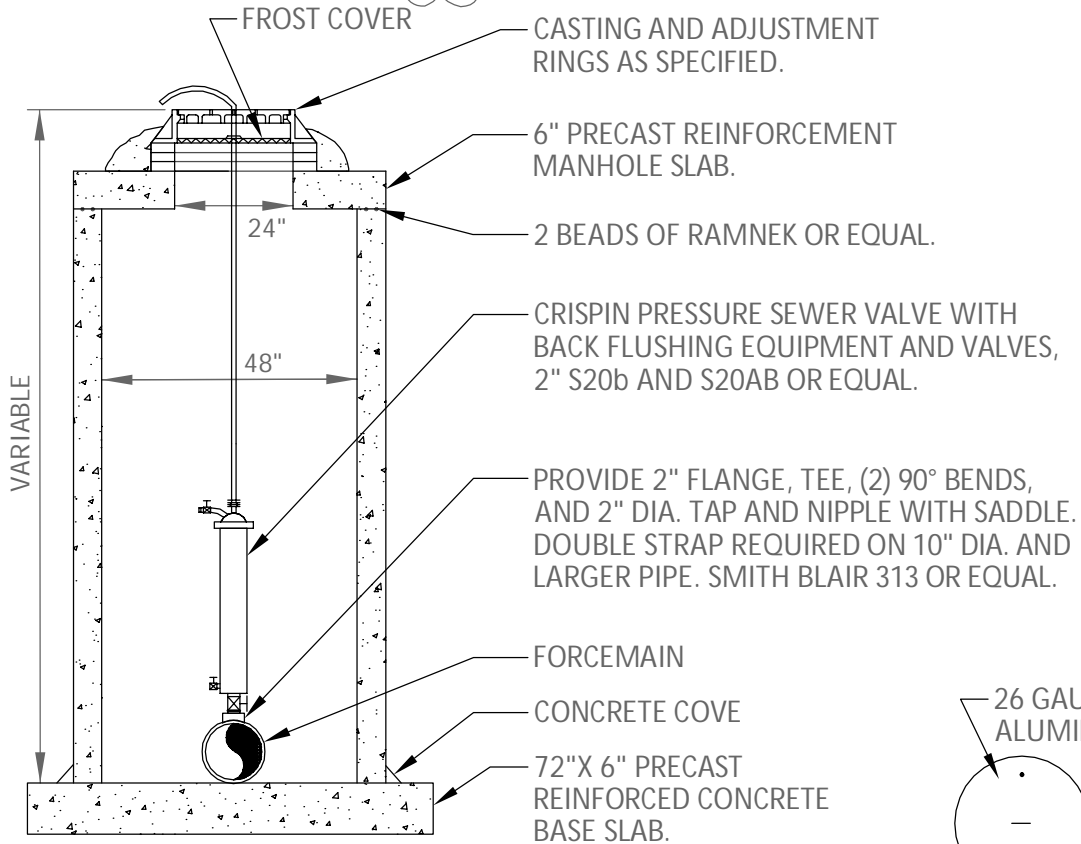
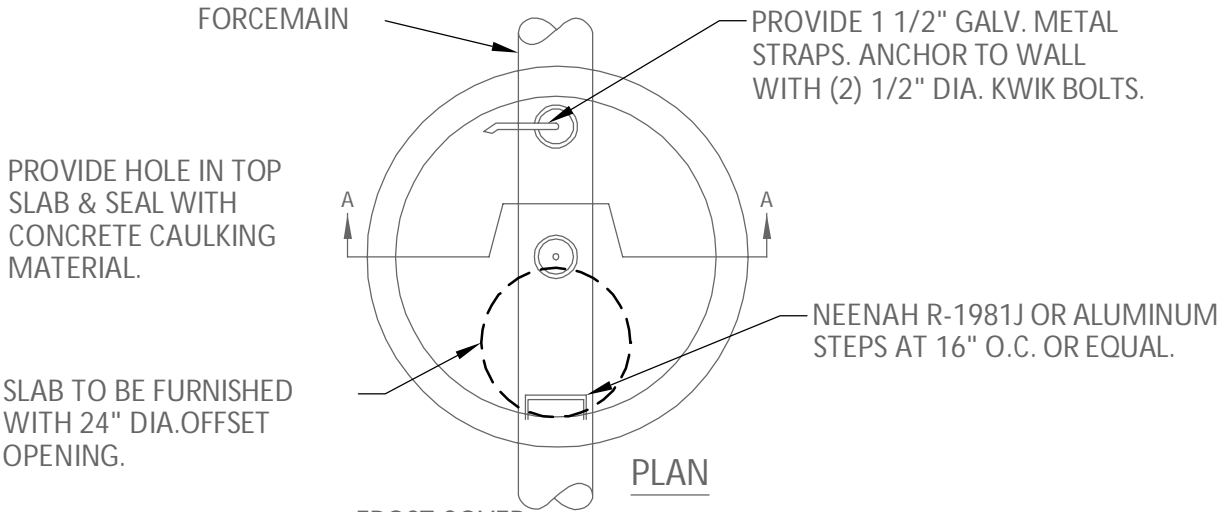

**NOTES:**

1. WHEN THE MANHOLE OR CATCH BASIN STRUCTURE IS CONSTRUCTED OUTSIDE THE TRAVELED ROADWAY, A WITNESS POST AND SIGN SHALL BE INSTALLED NEXT TO THE MANHOLE.

**SECTION A-A**



**STANDARD DETAILS**

**AIR RELEASE MANHOLE**

**FRIDLEY, MINNESOTA**

LAST REVISION:  
DEC 2018

CITY PLATE NO.  
SAN-5



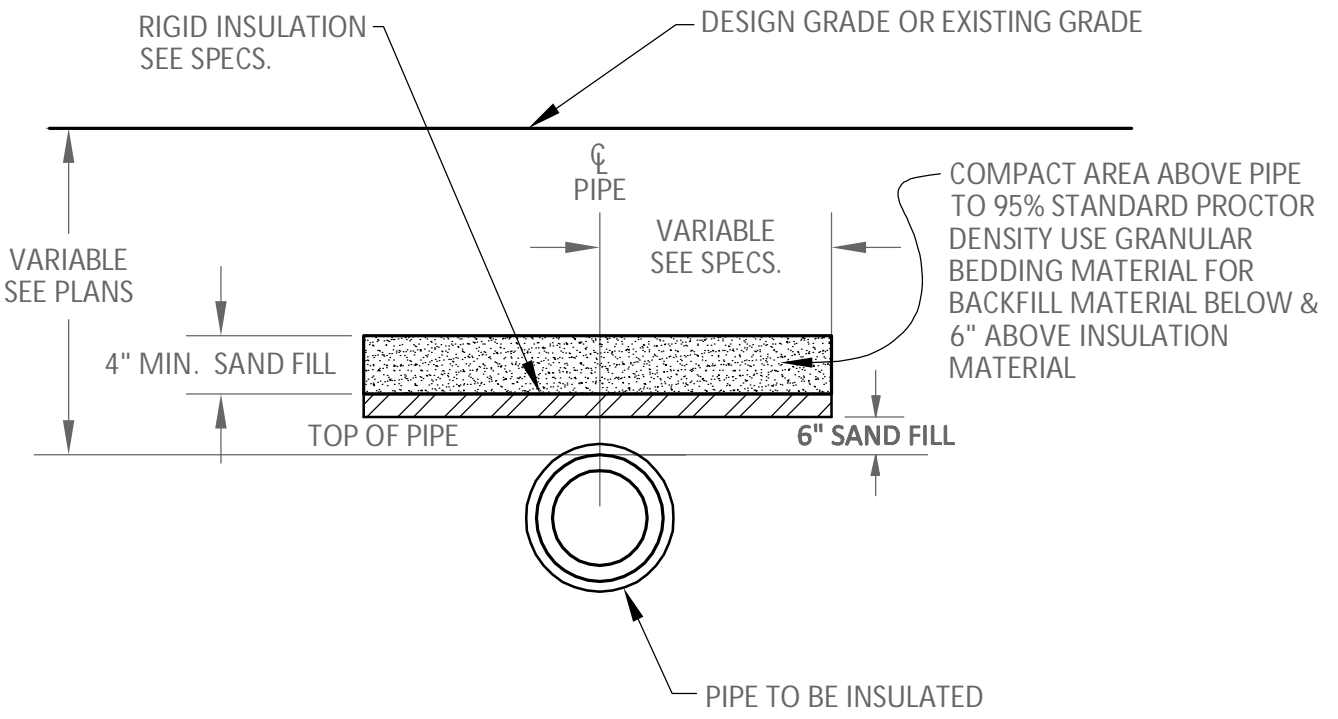

STANDARD DETAILS

SEWER INSULATION

**FRIDLEY, MINNESOTA**

LAST REVISION:  
 DEC 2018

CITY PLATE NO.  
**SAN-6**

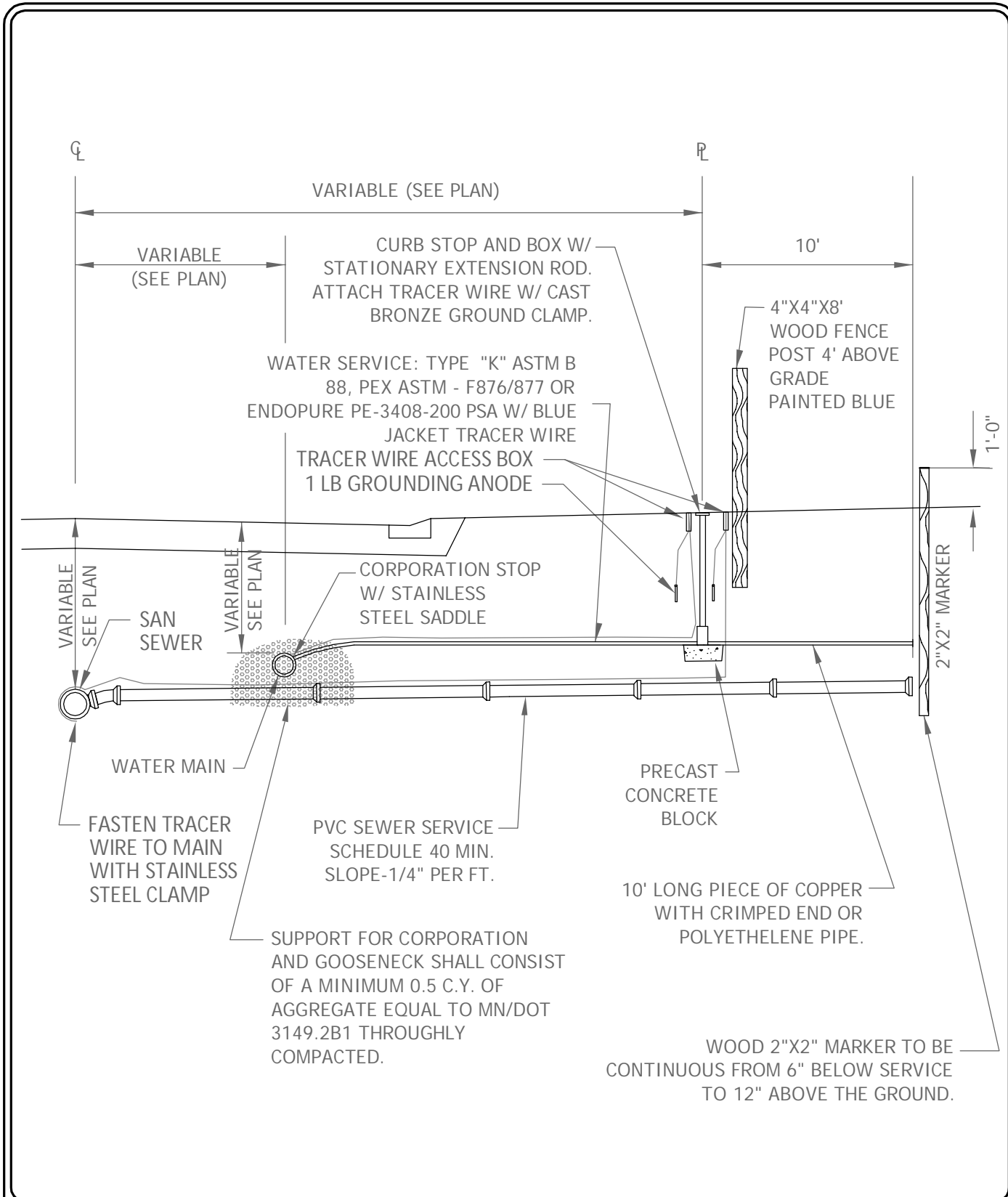

**STANDARD DETAILS**  
**SEWER AND WATER**  
**SERVICE CONNECTIONS**

**FRIDLEY, MINNESOTA**

LAST REVISION:  
 DEC 2018

CITY PLATE NO.  
 SER-1

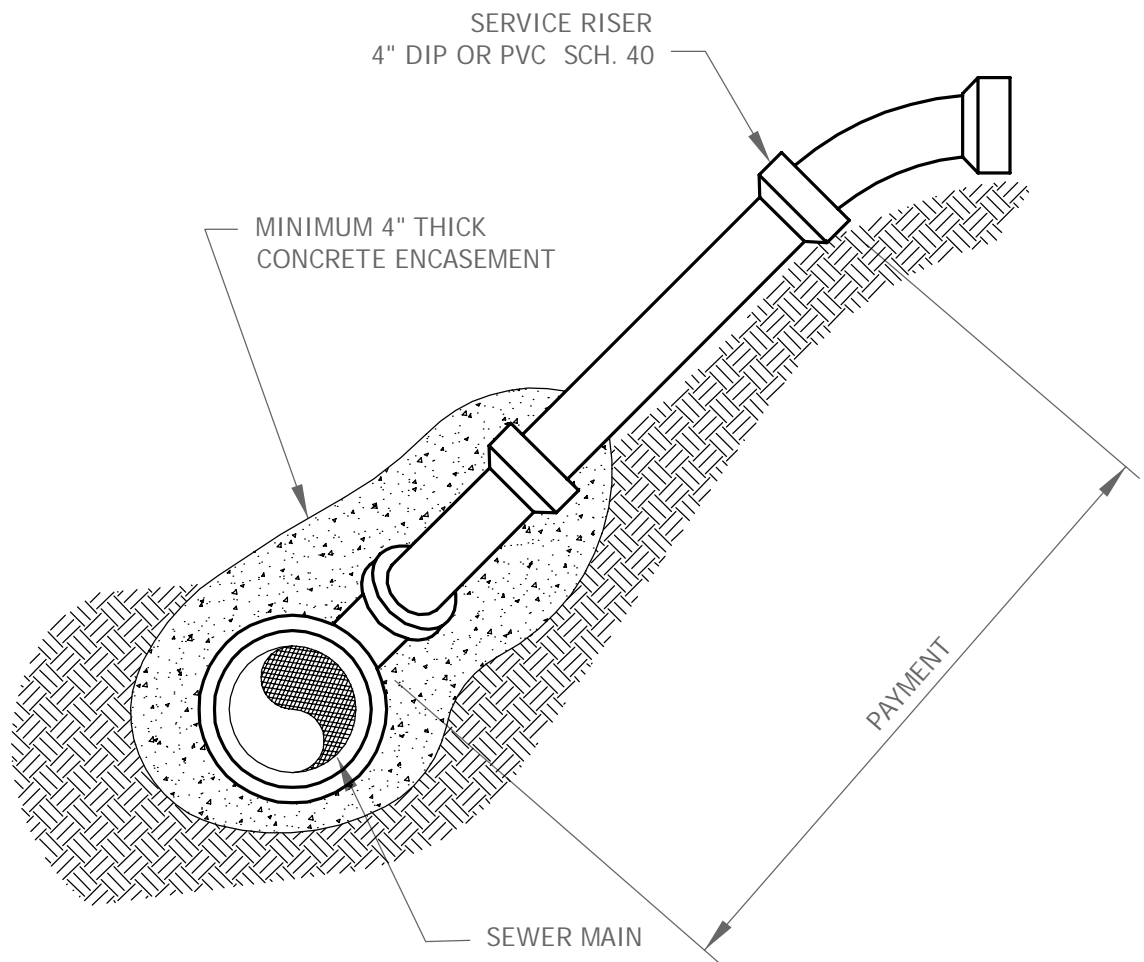

STANDARD DETAILS

SERVICE RISER

**FRIDLEY, MINNESOTA**

LAST REVISION:  
DEC 2018

CITY PLATE NO.  
SER-2

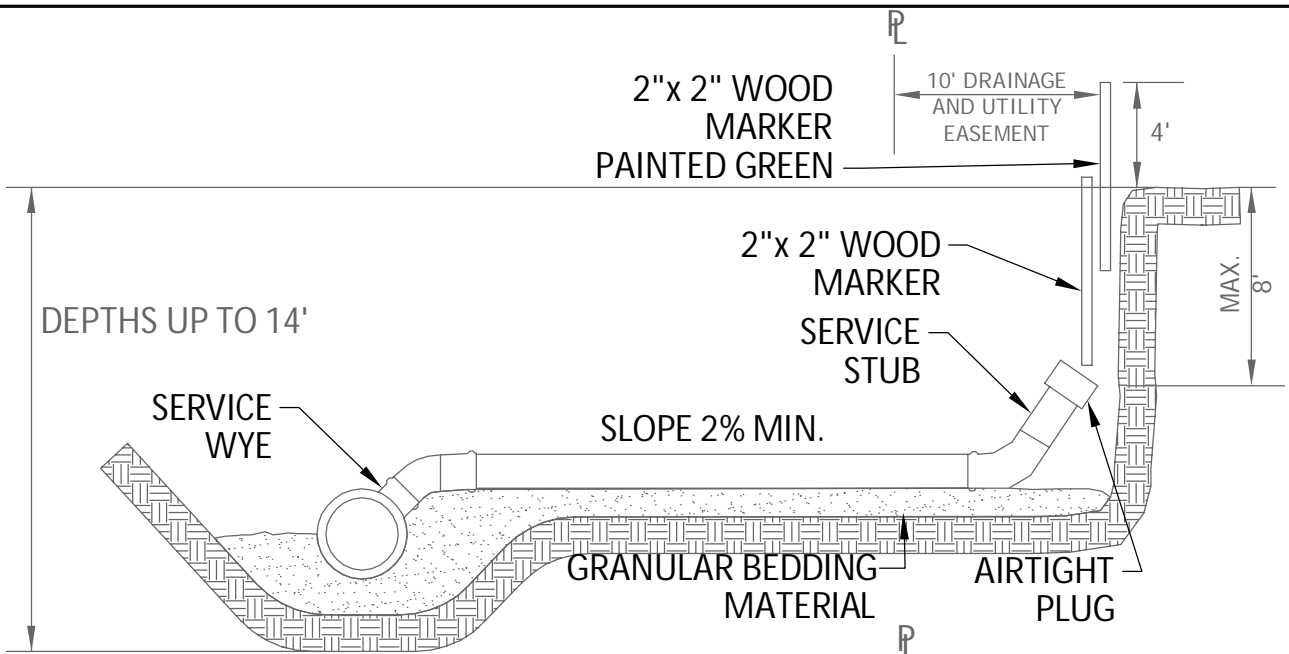

**WITHOUT RISER**

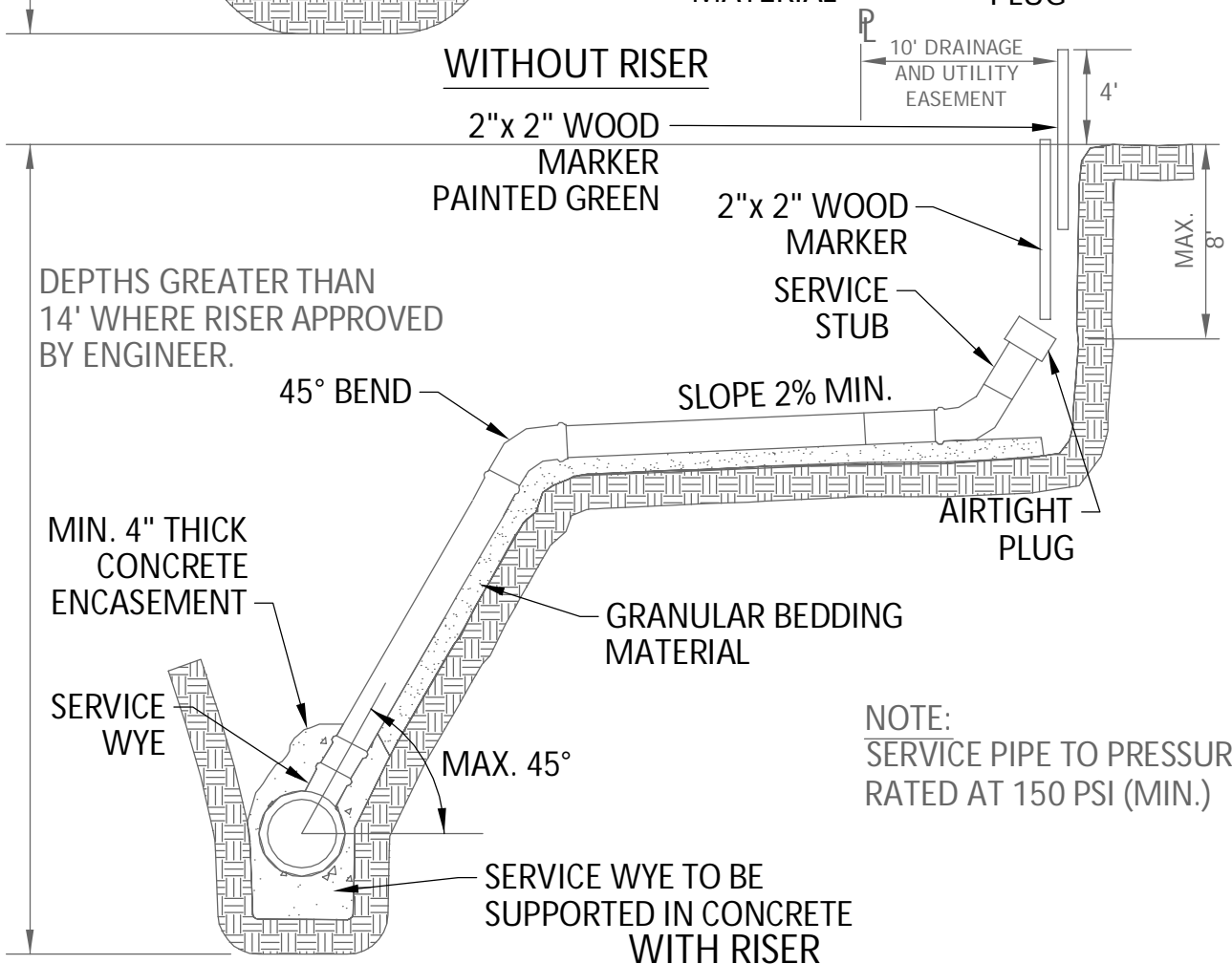

**NOTE:**  
SERVICE PIPE TO PRESSURE  
RATED AT 150 PSI (MIN.)



**STANDARD DETAILS**  
SANITARY SEWER SERVICE

**FRIDLEY, MINNESOTA**

LAST REVISION:  
DEC 2018

CITY PLATE NO.  
SER-3

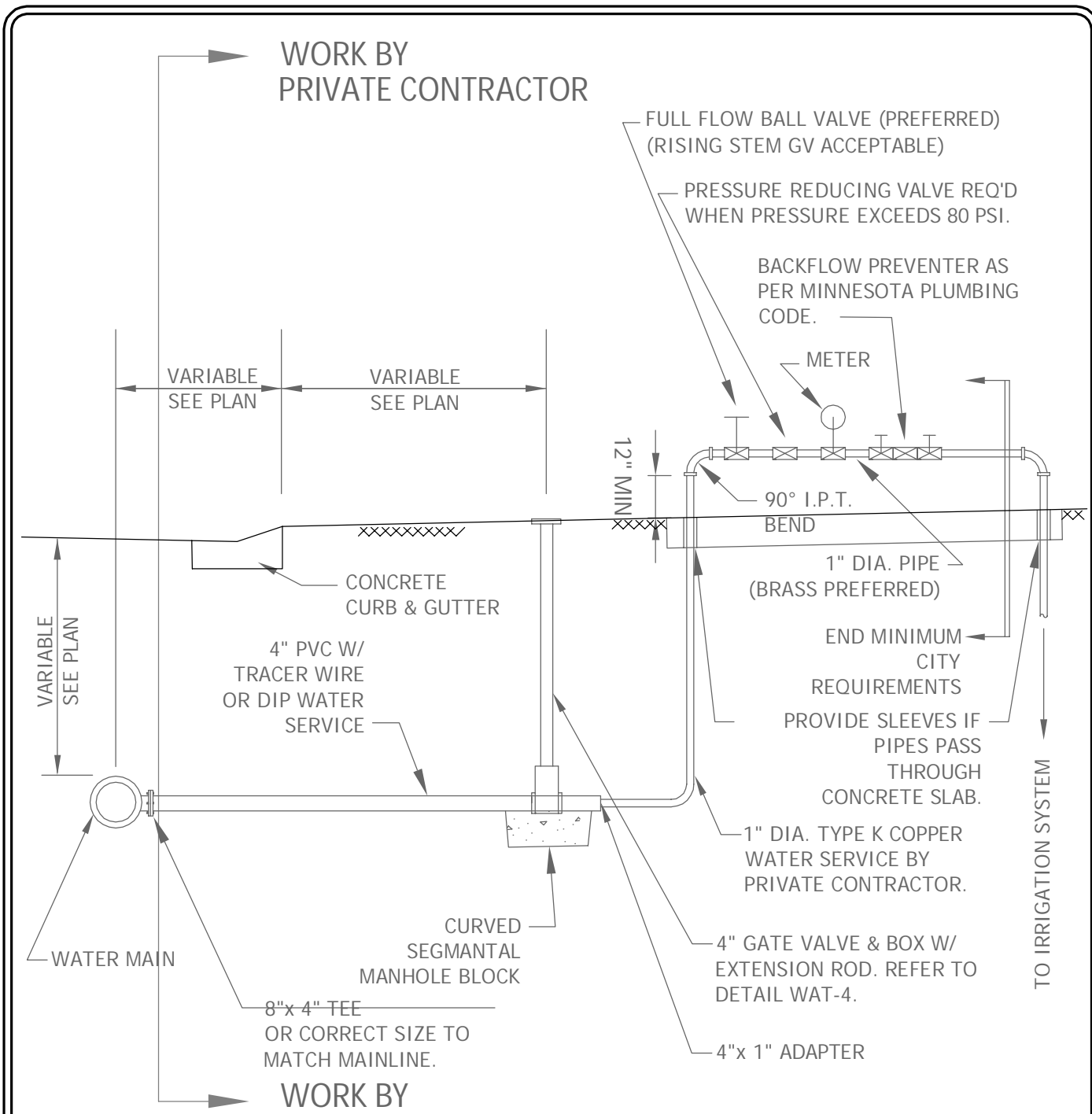

NOTES:

**WORK BY PRIVATE CONTRACTOR**

1. CITY WATER SERVICE & PLUMBING PERMITS REQUIRED FOR WORK BY PRIVATE CONTRACTORS.
2. ANNUAL TESTING OF RPZ REQUIRED.
3. REQUIRED EQUIPMENT MUST BE ENCLOSED AND SUPPORTED.
4. SLEEVES FOR PIPES IN CONCRETE SLABS SHALL BE 4" DIAMETER PVC OR SIMILAR.



**STANDARD DETAILS**  
**IRRIGATION SERVICE**  
**BY PRIVATE CONTRACTOR**

**FRIDLEY, MINNESOTA**

LAST REVISION:  
 DEC 2018

CITY PLATE NO.  
 SER-5A

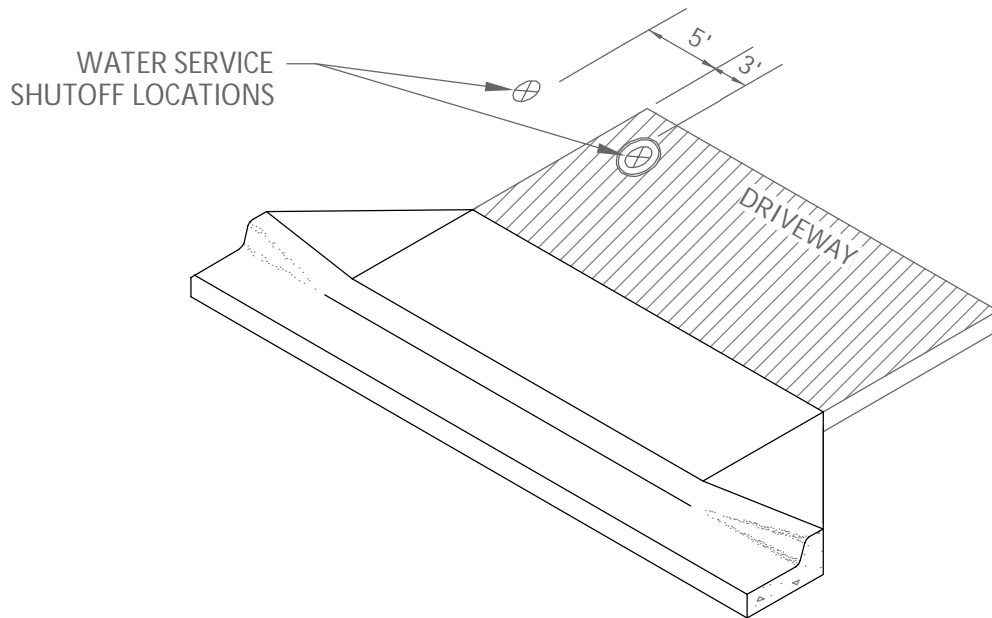

ISOMETRIC  
NO SCALE

NOTES:

1. WATER SERVICE SHUTOFF TO BE LOCATED A MINIMUM OF 5' OUTSIDE OF THE DRIVEWAY EDGE, OR A MINIMUM OF 3' INSIDE OF THE DRIVEWAY EDGE.
2. SHUT OFFS LOCATED IN THE DRIVEWAY WILL REQUIRE A NEENAH R-1914-A CASTING WITH A LOCKING COVER OR APPROVED EQUAL.



STANDARD DETAILS

WATER SERVICE SHUT OFF LOCATION

**FRIDLEY, MINNESOTA**

LAST REVISION:  
DEC 2018

CITY PLATE NO.  
SER-6

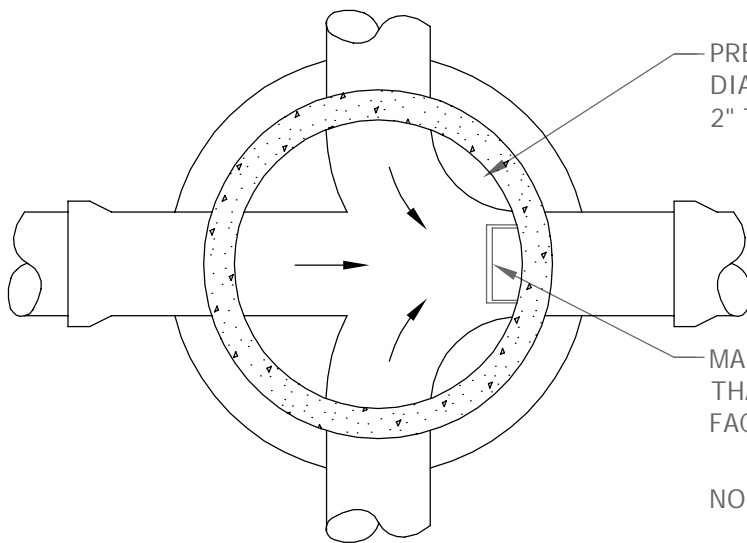

PLAN

PRECAST INVERT SHOULD BE 1/2 DIAMETER OF PIPE AND BENCHES SLOPED 2" TOWARD INVERT.

MANHOLE STEPS SHALL BE PLACED SO THAT OFFSET HOLE IN TOP SLAB IS FACING DOWNSTREAM.

NO BLOCK STRUCTURES ARE ALLOWED.

CASTING AND ADJUSTMENT RINGS AS SPECIFIED.

6" PRECAST REINFORCED CONCRETE MANHOLE SLAB WITH #4 BARS AT 5" O.C. EACH WAY, AND 2-#4 BARS AT ALL SIDES OF OPENING. FOR 6" DIA. MANHOLE, AN 8" PRECAST SLAB IS REQUIRED.

TOP OF BARREL SECTION BELOW TOP SLAB TO HAVE FLAT TOP EDGE SEALED WITH 2 BEADS OF RAMNEK OR EQUAL.

ALL JOINTS IN MANHOLE TO HAVE "O" RING RUBBER GASKETS.

DOGHOUSES MUST BE GROUTED BOTH INSIDE AND OUTSIDE AND SHAPED TO PREVENT STANDING WATER.

PIPE SHALL BE INSERTED INTO STRUCTURE 1' MINIMUM

MINIMUM SLAB THICKNESS IS 6" FOR 14' DEPTH. INCREASE THICKNESS 1" FOR EVERY 4' OF DEPTH GREATER THAN 14', AND REINFORCE WITH 6"x 6" 10/10.

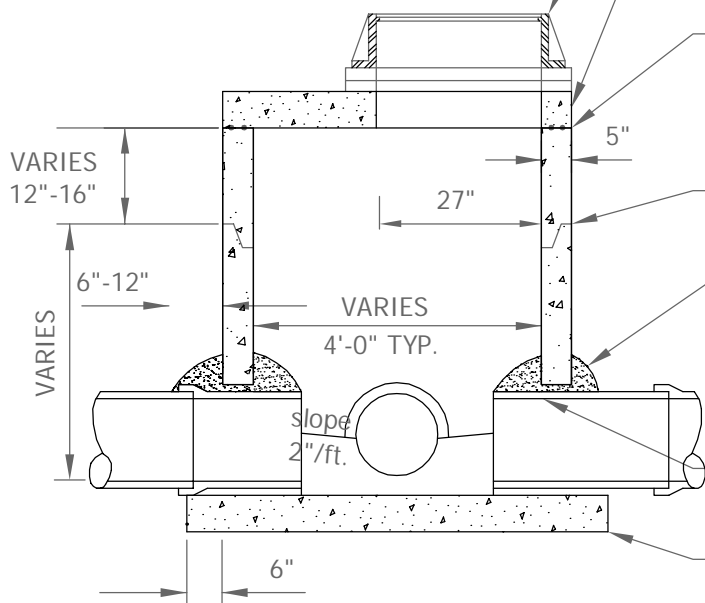

SECTION



STANDARD DETAILS  
STORM SEWER JUNCTION MANHOLE  
WITH REINFORCED TOP SLAB

**FRIDLEY, MINNESOTA**

LAST REVISION:  
DEC 2018

CITY PLATE NO.  
STO-3

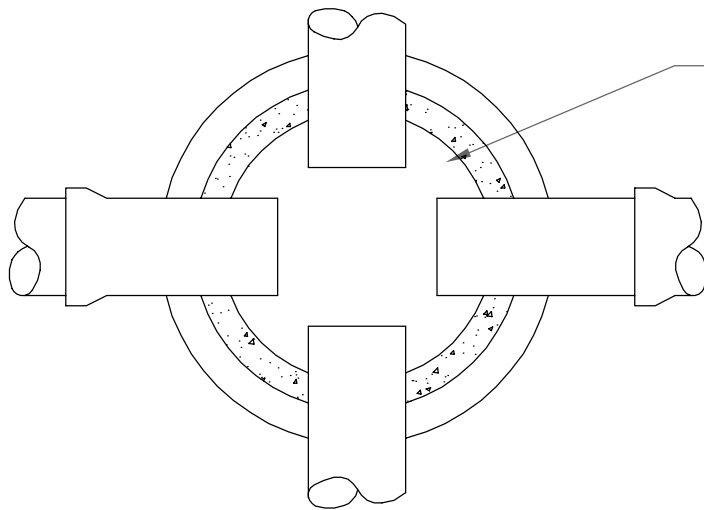

PRECAST INVERT SHOULD BE 1/2 DIAMETER OF PIPE AND BENCHES SLOPED 2" TOWARD INVERT.

PLAN

NO BLOCK STRUCTURES ARE ALLOWED.

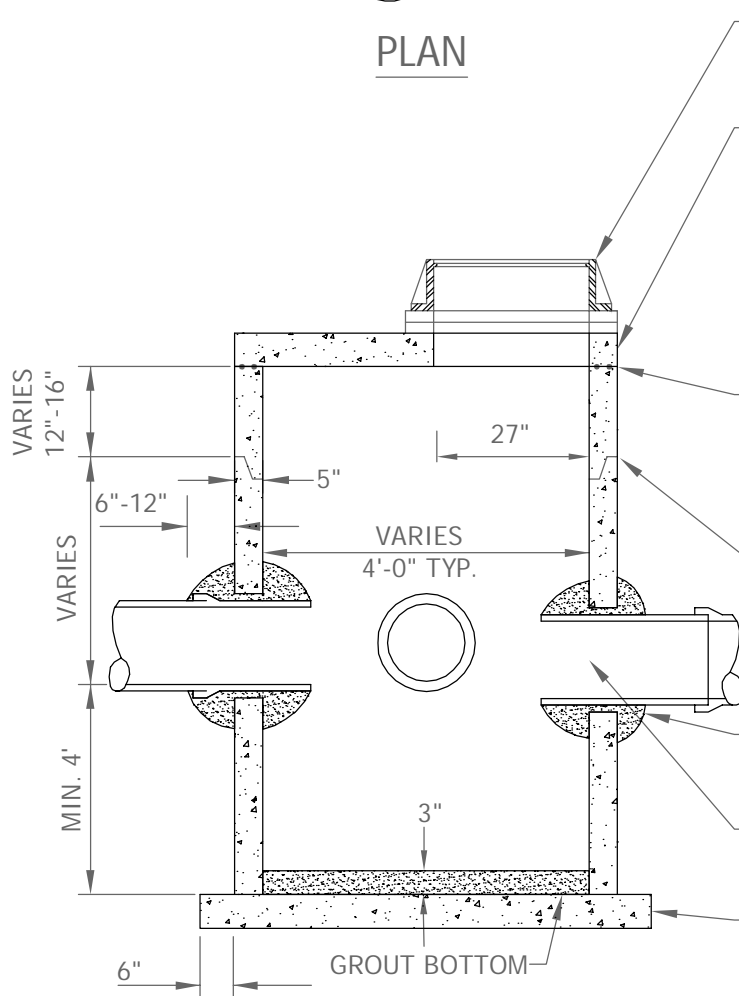

CASTING AND ADJUSTMENT RINGS AS SPECIFIED.

6" PRECAST REINFORCED CONCRETE MANHOLE SLAB WITH #4 BARS AT 5" O.C. EACH WAY, AND 2-#4 BARS AT ALL SIDES OF OPENING. FOR 6" DIA. MANHOLE, AN 8" PRECAST SLAB IS REQUIRED.

TOP OF BARREL SECTION BELOW TOP SLAB TO HAVE FLAT TOP EDGE SEALED WITH 2 BEADS OF RAMNEK OR EQUAL.

ALL JOINTS IN MANHOLE TO HAVE "O" RING RUBBER GASKETS.

DOGHOUSES MUST BE GROUTED BOTH INSIDE AND OUTSIDE AND SHAPED TO PREVENT STANDING WATER.

PIPE SHALL BE INSERTED INTO STRUCTURE 1' MINIMUM

MINIMUM SLAB THICKNESS IS 6" FOR 14' DEPTH. INCREASE THICKNESS 1" FOR EVERY 4' OF DEPTH GREATER THAN 14', AND REINFORCE WITH 6"x 6" 10/10.

SECTION



STANDARD DETAILS  
STORM SEWER JUNCTION MANHOLE  
WITH REINFORCED TOP SLAB & SUMP

**FRIDLEY, MINNESOTA**

LAST REVISION:  
DEC 2018

CITY PLATE NO.  
STO-4



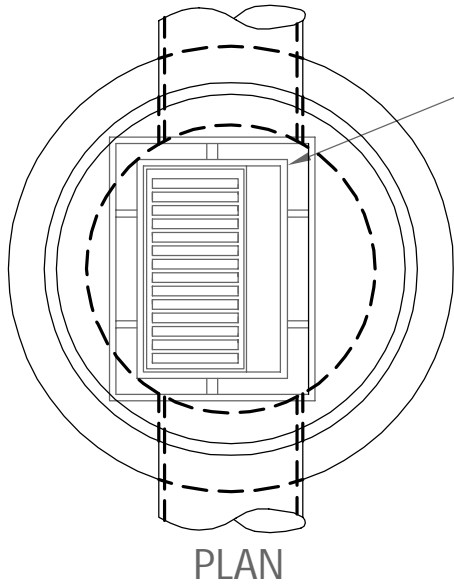

24"X36" SLAB OPENING FOR NEENAH R3067V OR ESS. BROS. 330 HIGH CAPACITY OR EQUAL. INSTALL R3290L FOR DRIVEWAYS AND VALLEY GUTTERS. (VANE GRATE SHOWN)

DIMENSION FROM BACK OF CURB TO CENTER OF PIPE.

- 4' DIA. MH - 9" IN FROM BACK OF CURB
- 5' DIA. MH - 3" IN FROM BACK OF CURB
- 6' DIA. MH - 3" BEHIND BACK OF CURB
- 7' DIA. MH - 9" BEHIND BACK OF CURB
- 8' DIA. MH - 15" BEHIND BACK OF CURB

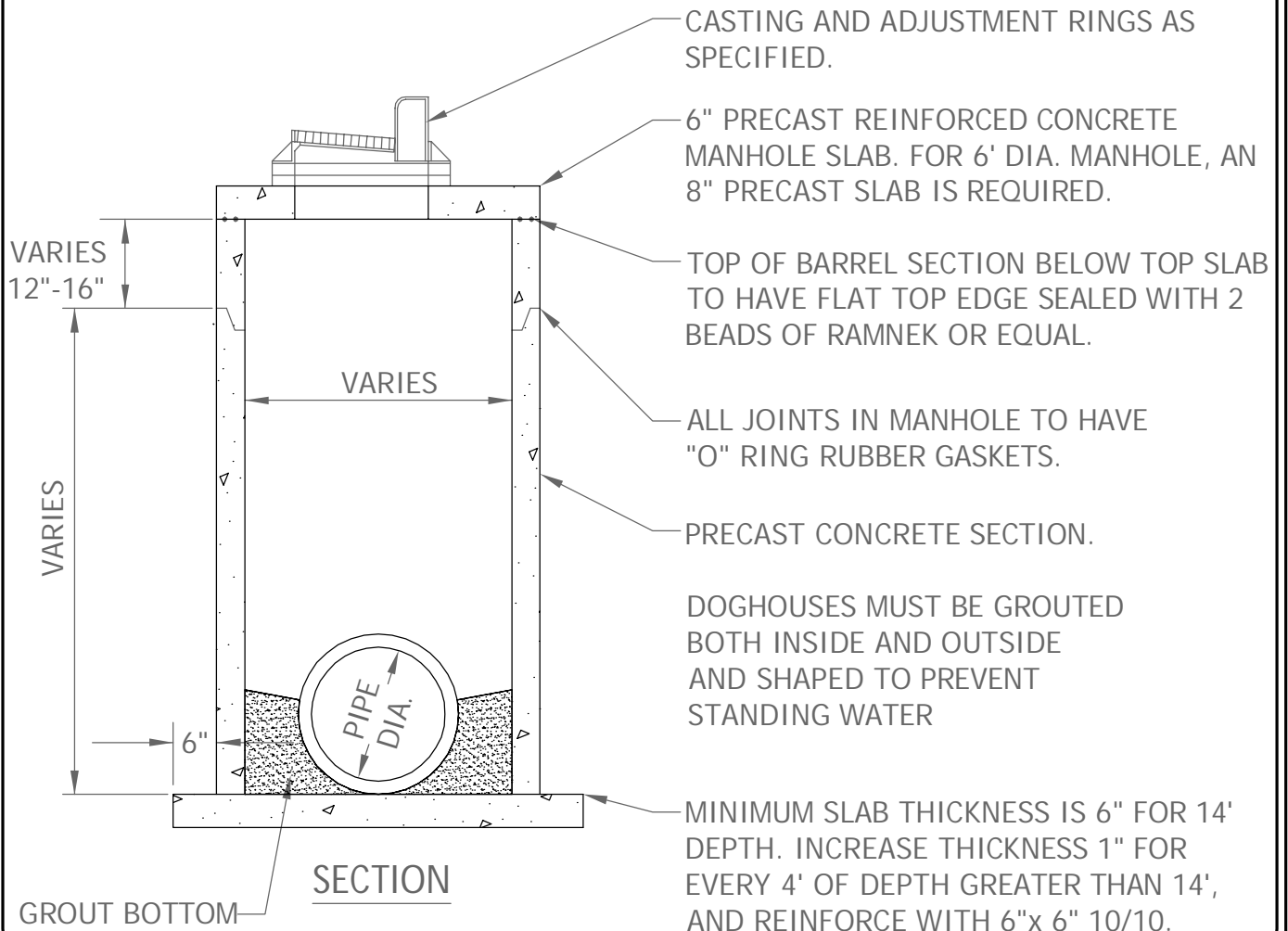

CASTING AND ADJUSTMENT RINGS AS SPECIFIED.

6" PRECAST REINFORCED CONCRETE MANHOLE SLAB. FOR 6' DIA. MANHOLE, AN 8" PRECAST SLAB IS REQUIRED.

TOP OF BARREL SECTION BELOW TOP SLAB TO HAVE FLAT TOP EDGE SEALED WITH 2 BEADS OF RAMNEK OR EQUAL.

ALL JOINTS IN MANHOLE TO HAVE "O" RING RUBBER GASKETS.

PRECAST CONCRETE SECTION.

DOGHOUSES MUST BE GROUTED BOTH INSIDE AND OUTSIDE AND SHAPED TO PREVENT STANDING WATER

MINIMUM SLAB THICKNESS IS 6" FOR 14' DEPTH. INCREASE THICKNESS 1" FOR EVERY 4' OF DEPTH GREATER THAN 14', AND REINFORCE WITH 6"x 6" 10/10.



STANDARD DETAILS  
TYPE II  
CATCHBASIN MANHOLE

**FRIDLEY, MINNESOTA**

LAST REVISION:  
DEC 2018

CITY PLATE NO.  
STO-5

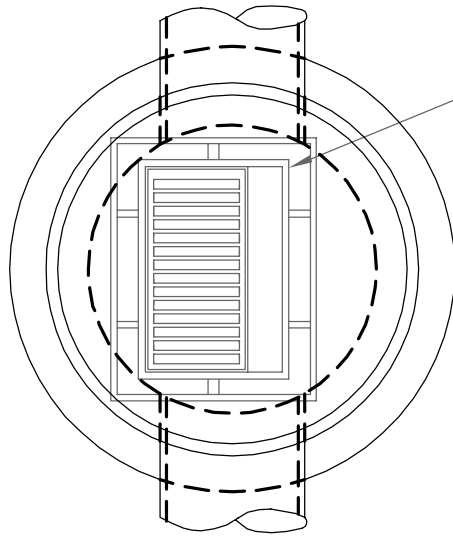

24"X36" SLAB OPENING FOR CASTING AS SPECIFIED.

DIMENSION FROM BACK OF CURB TO CENTER OF PIPE.

- 4' DIA. MH - 9" IN FROM BACK OF CURB
- 5' DIA. MH - 3" IN FROM BACK OF CURB
- 6' DIA. MH - 3" BEHIND BACK OF CURB
- 7' DIA. MH - 9" BEHIND BACK OF CURB
- 8' DIA. MH - 15" BEHIND BACK OF CURB

**PLAN**

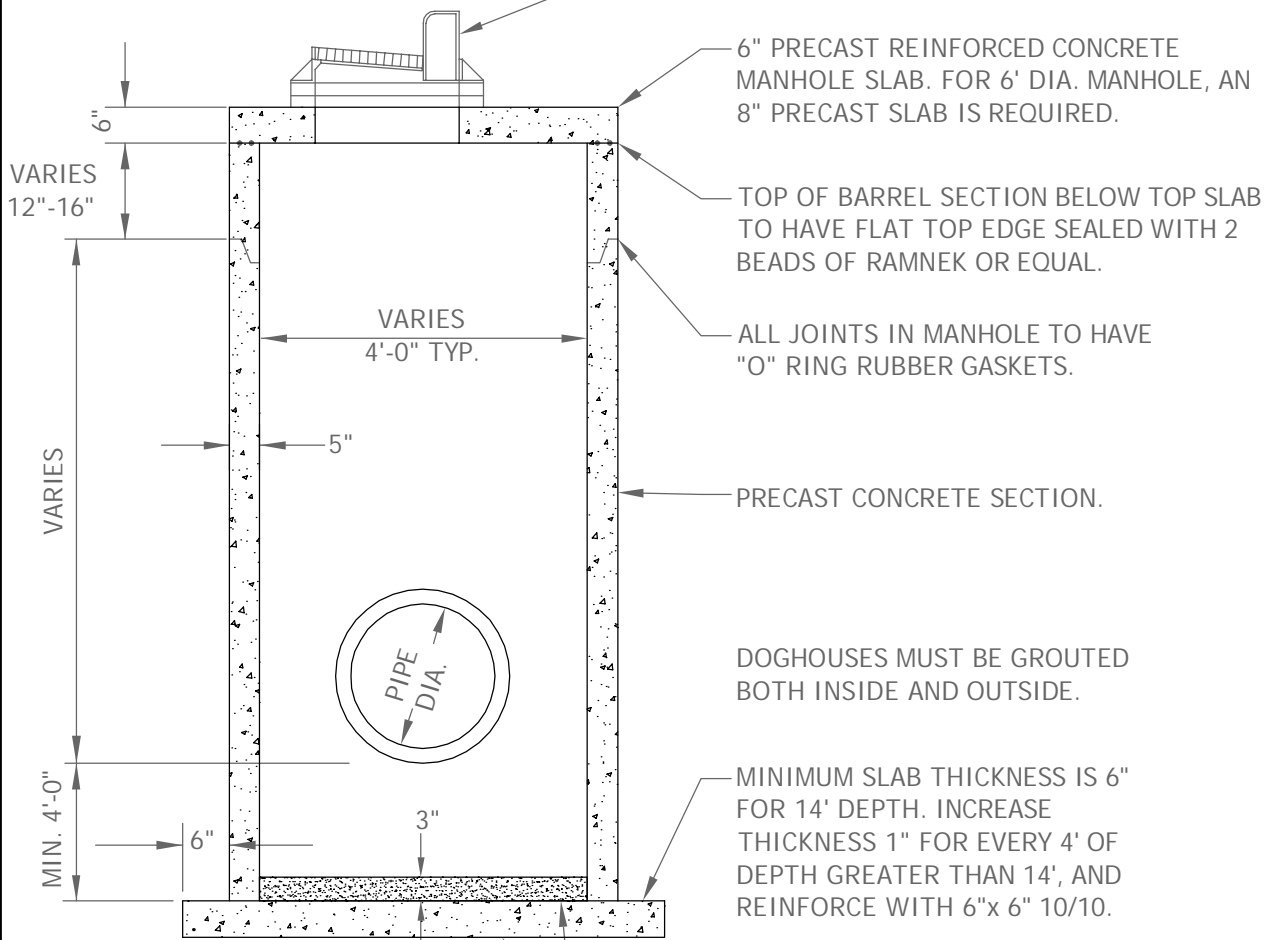

CASTING AND ADJUSTMENT RINGS AS SPECIFIED.

6" PRECAST REINFORCED CONCRETE MANHOLE SLAB. FOR 6' DIA. MANHOLE, AN 8" PRECAST SLAB IS REQUIRED.

TOP OF BARREL SECTION BELOW TOP SLAB TO HAVE FLAT TOP EDGE SEALED WITH 2 BEADS OF RAMNEK OR EQUAL.

ALL JOINTS IN MANHOLE TO HAVE "O" RING RUBBER GASKETS.

PRECAST CONCRETE SECTION.

DOGHOUSES MUST BE GROUTED BOTH INSIDE AND OUTSIDE.

MINIMUM SLAB THICKNESS IS 6" FOR 14' DEPTH. INCREASE THICKNESS 1" FOR EVERY 4' OF DEPTH GREATER THAN 14', AND REINFORCE WITH 6"x 6" 10/10.

**SECTION**

GROUT BOTTOM  
NO DRAIN HOLES



**STANDARD DETAILS**  
**CATCHBASIN MANHOLE**  
**WITH SUMP**

**FRIDLEY, MINNESOTA**

LAST REVISION:  
DEC 2018

CITY PLATE NO.  
STO-6

NOTE:  
VANE GRATE SHOWN

DIRECTION OF FLOW  
→

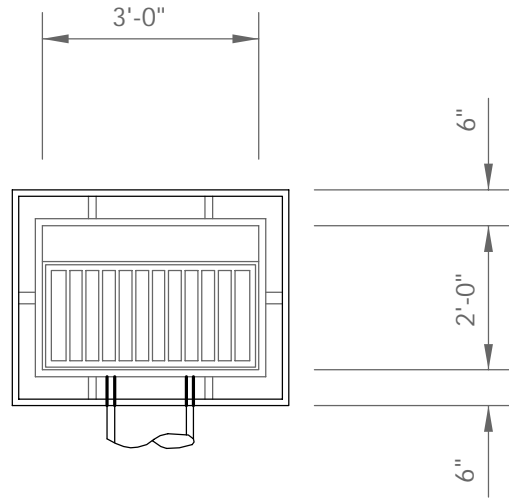

PLAN

NO BLOCK STRUCTURES ARE ALLOWED.

CASTING AND  
ADJUSTMENT RINGS  
AS SPECIFIED.

GRATE TO BE 2" BELOW  
GUTTER GRADE. 10"  
TRANSITION EACH SIDE OF  
CATCH BASIN.

DOGHOUSES SHALL BE  
GROUTED ON BOTH THE  
INSIDE AND OUTSIDE.

GROUTED INVERT

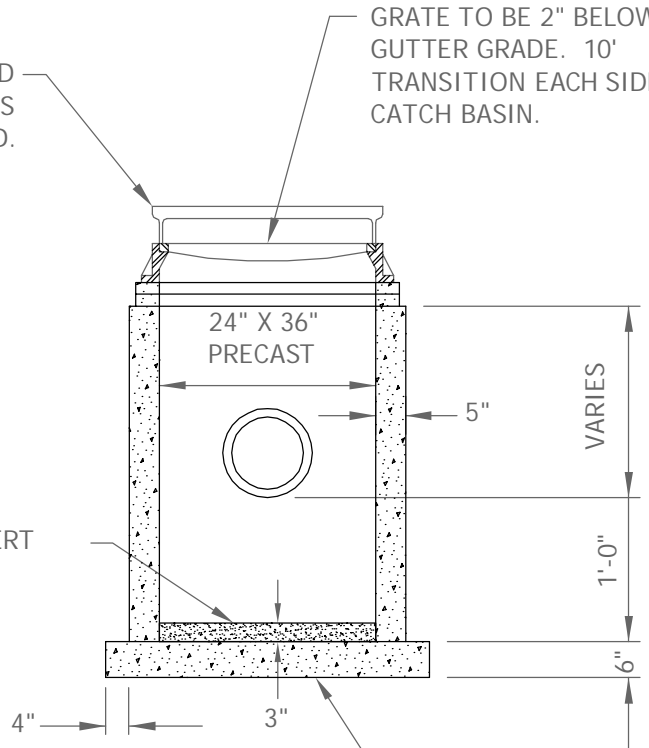

SECTION

NO DRAIN HOLES



STANDARD DETAILS  
CATCHBASIN WITH SUMP

FRIDLEY, MINNESOTA

LAST REVISION:  
DEC 2018

CITY PLATE NO.  
STO-8

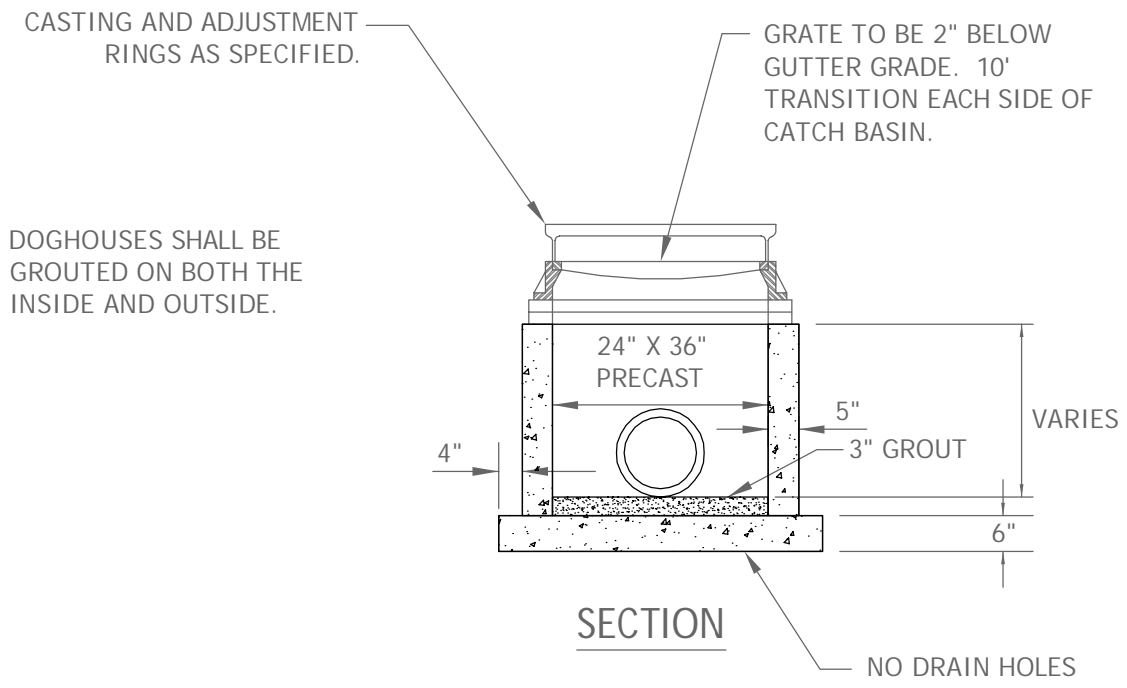
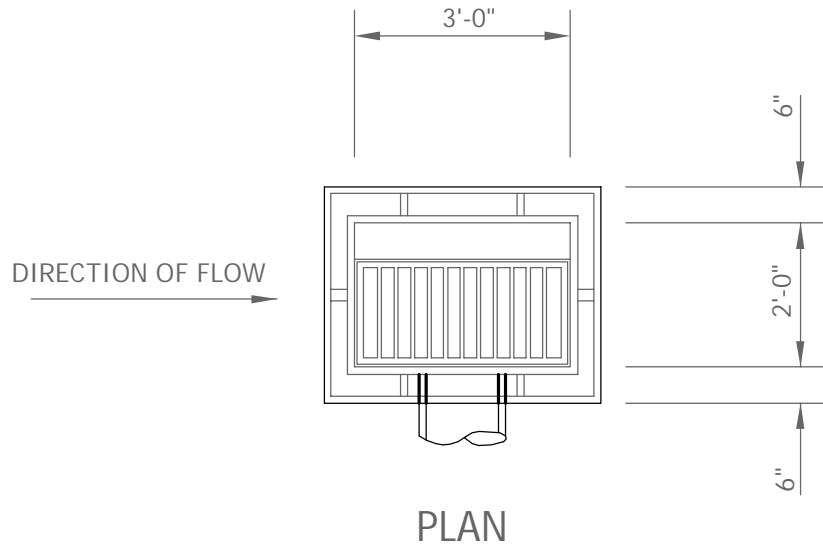

STANDARD DETAILS

2' X 3' CATCHBASIN WITHOUT SUMP

**FRIDLEY, MINNESOTA**

LAST REVISION:  
DEC 2018

CITY PLATE NO.  
STO-9

SEE CITY PLATE NO. STO-13 FOR RIPRAP PLACEMENT.

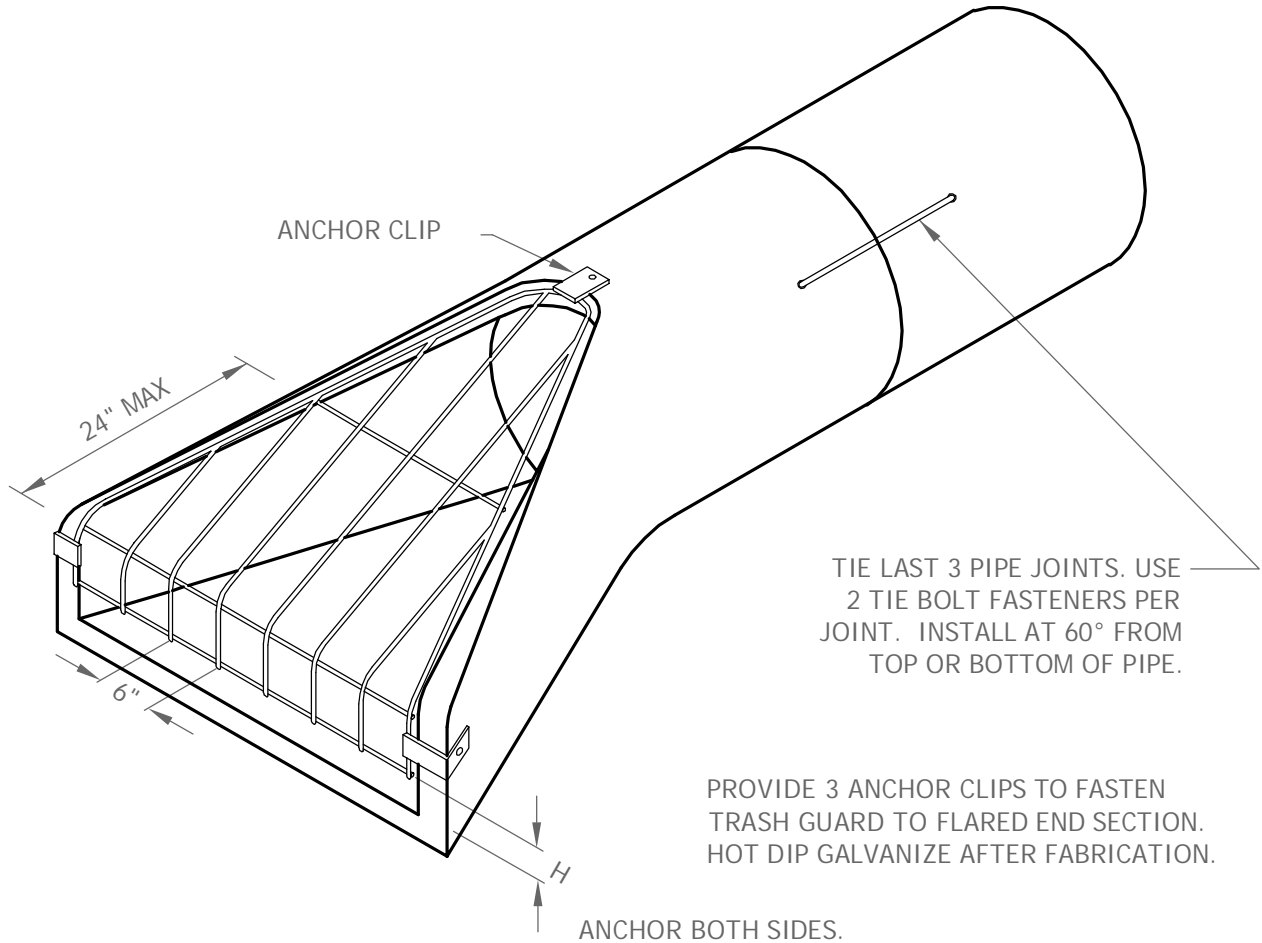

ISOMETRIC

PIPE SIZE	TRASH GUARD SIZING		
	BARS	'H'	BOLTS
12" - 18"	3/4"φ	4"	5/8"
21" - 42"	1"φ	6"	3/4"
48" - 72"	1 1/4"φ	12"	1"



STANDARD DETAILS  
FLARED END SECTION  
AND TRASH GUARD

FRIDLEY, MINNESOTA

LAST REVISION:  
DEC 2018

CITY PLATE NO.  
STO-12

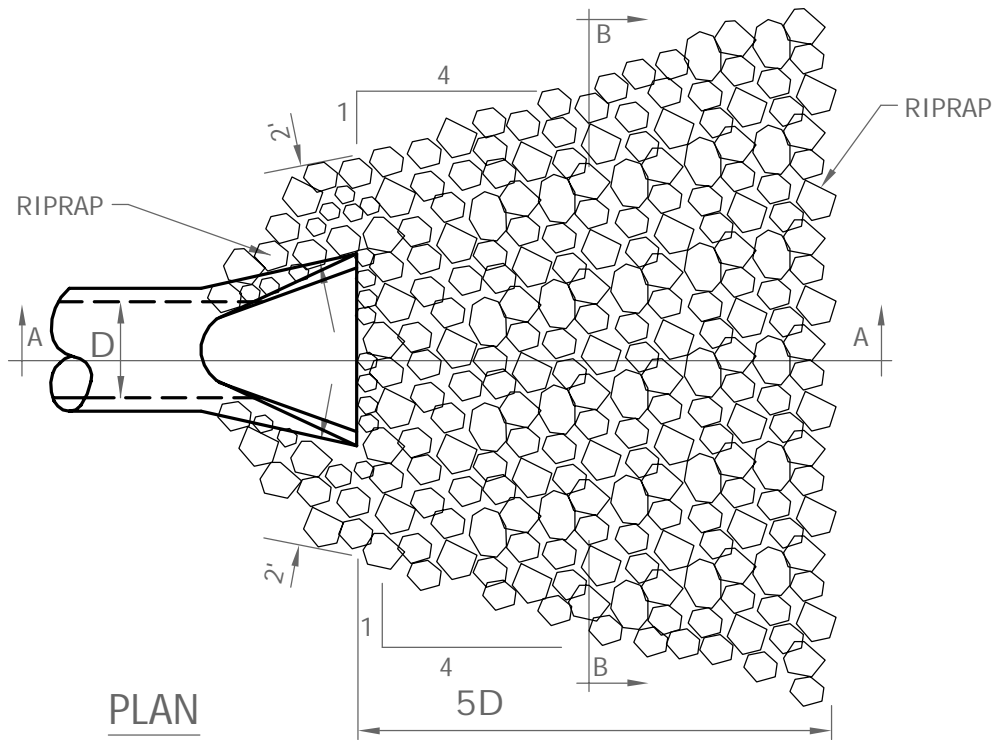

**RIPRAP REQUIREMENTS**

D	CY	CLASS
12" TO 24"	8 TO 12	CL.3
27" TO 33"	14 TO 20	CL.3
36" TO 48"	23 TO 38	CL.3
54" AND UP	62 AND UP	CL.4

(ONE CUBIC YARD IS APPROXIMATELY 2,800 LBS.)

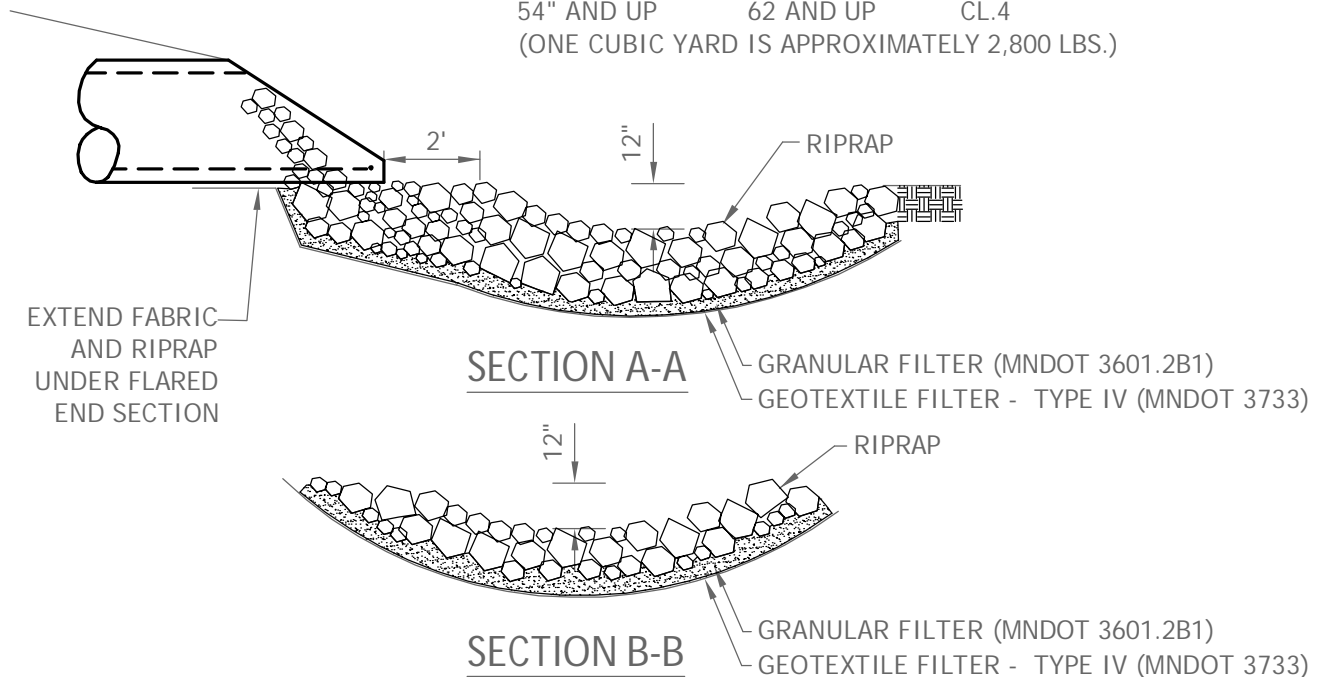

**STANDARD DETAILS**

**RIPRAP AT OUTLETS**

**FRIDLEY, MINNESOTA**

LAST REVISION:  
DEC 2018

CITY PLATE NO.  
STO-13

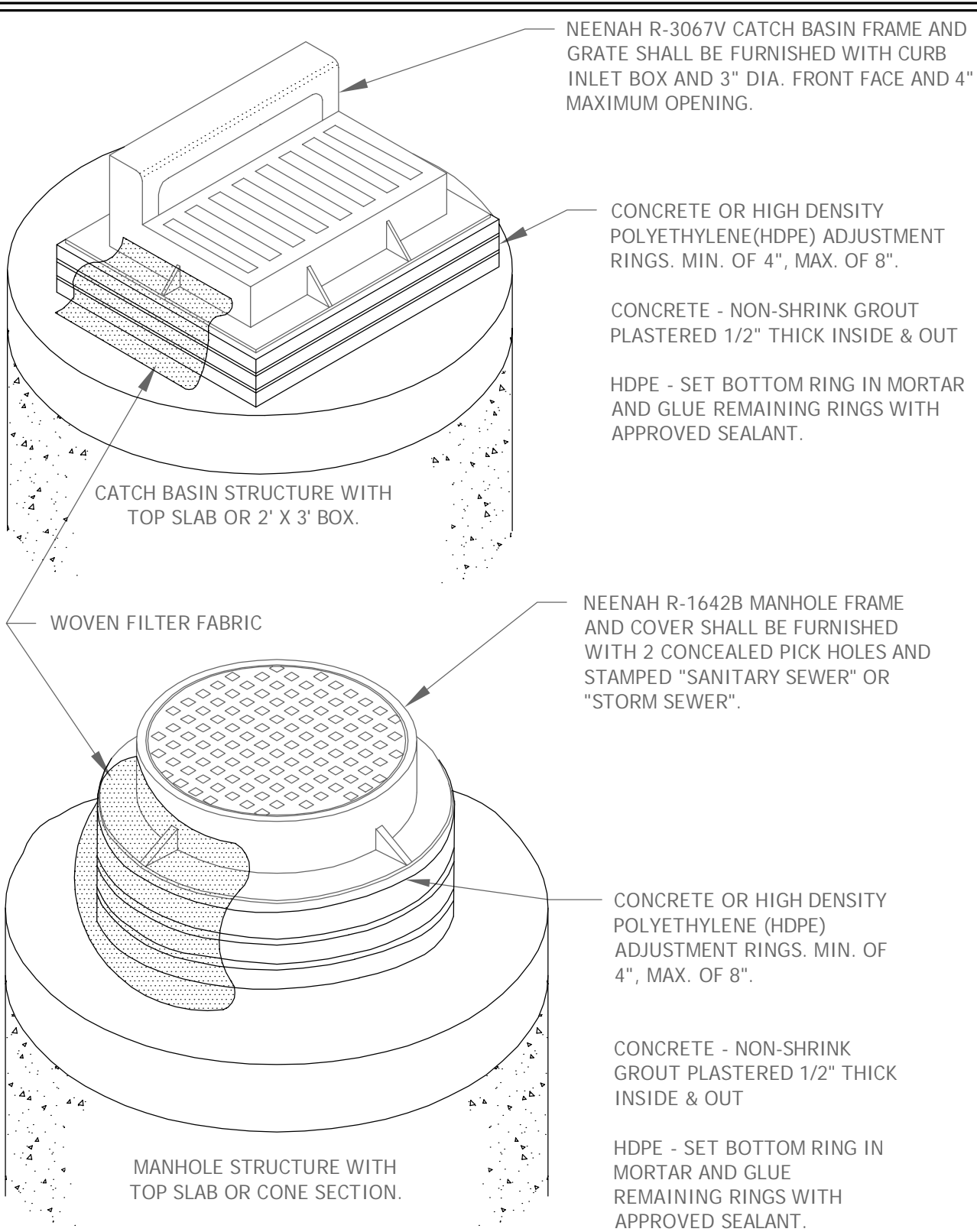

STANDARD DETAILS  
CATCH BASIN AND MANHOLE ADJUSTMENT

FRIDLEY, MINNESOTA

LAST REVISION:  
DEC 2018

CITY PLATE NO.  
STO-18

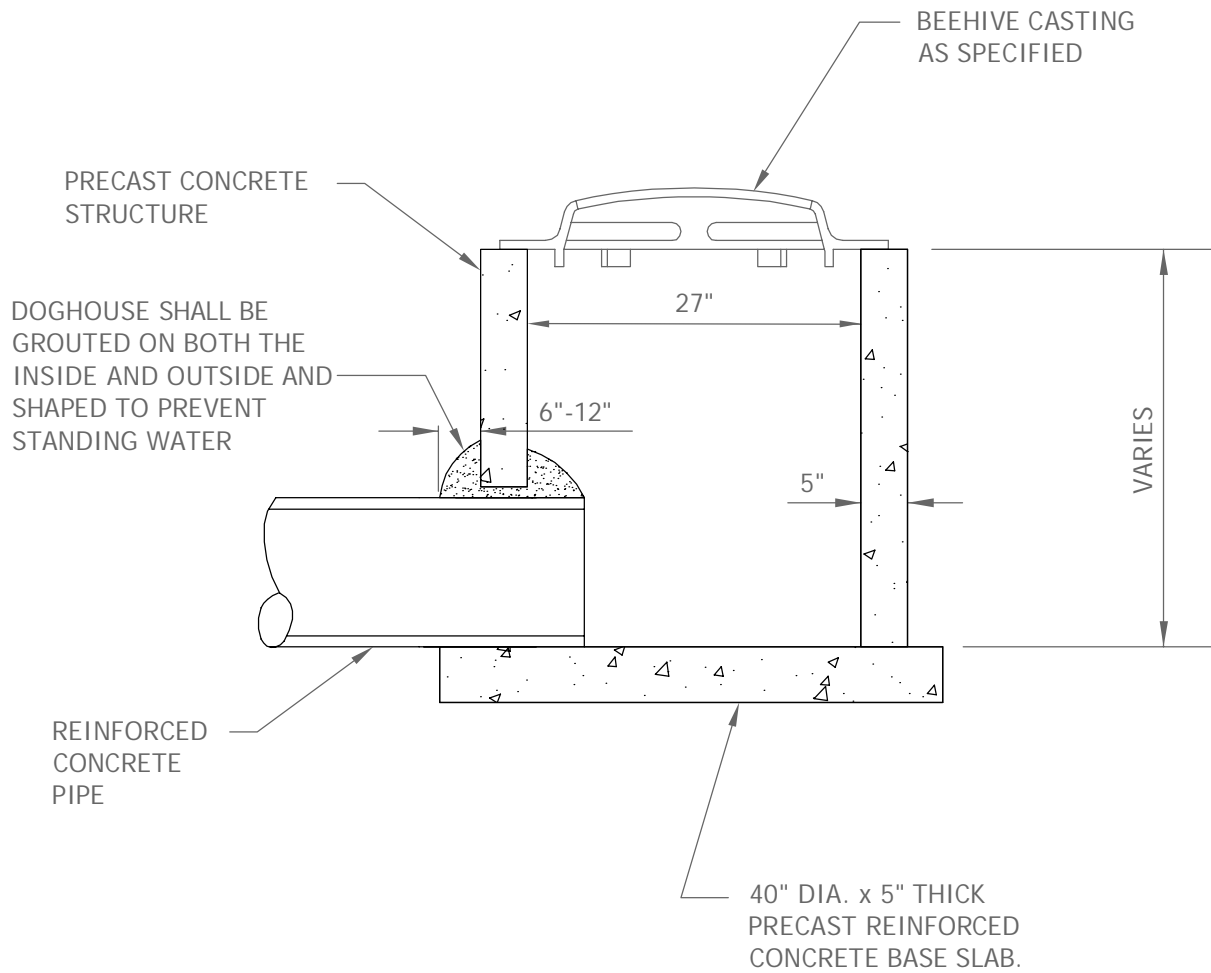

STANDARD DETAILS  
 PRECAST 27" SHALLOW  
 DEPTH BEEHIVE

**FRIDLEY, MINNESOTA**

LAST REVISION:  
 DEC 2018

CITY PLATE NO.  
 STO-28



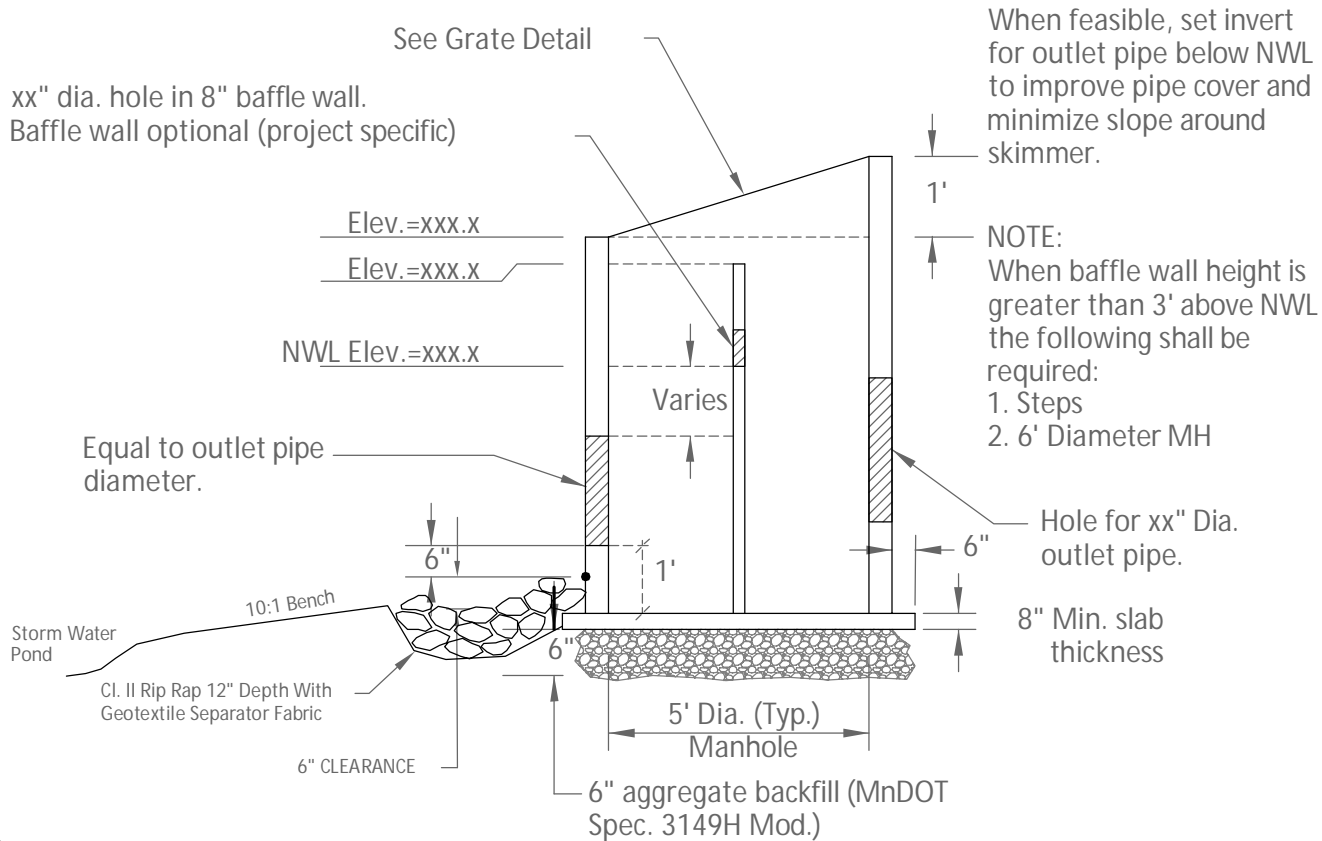
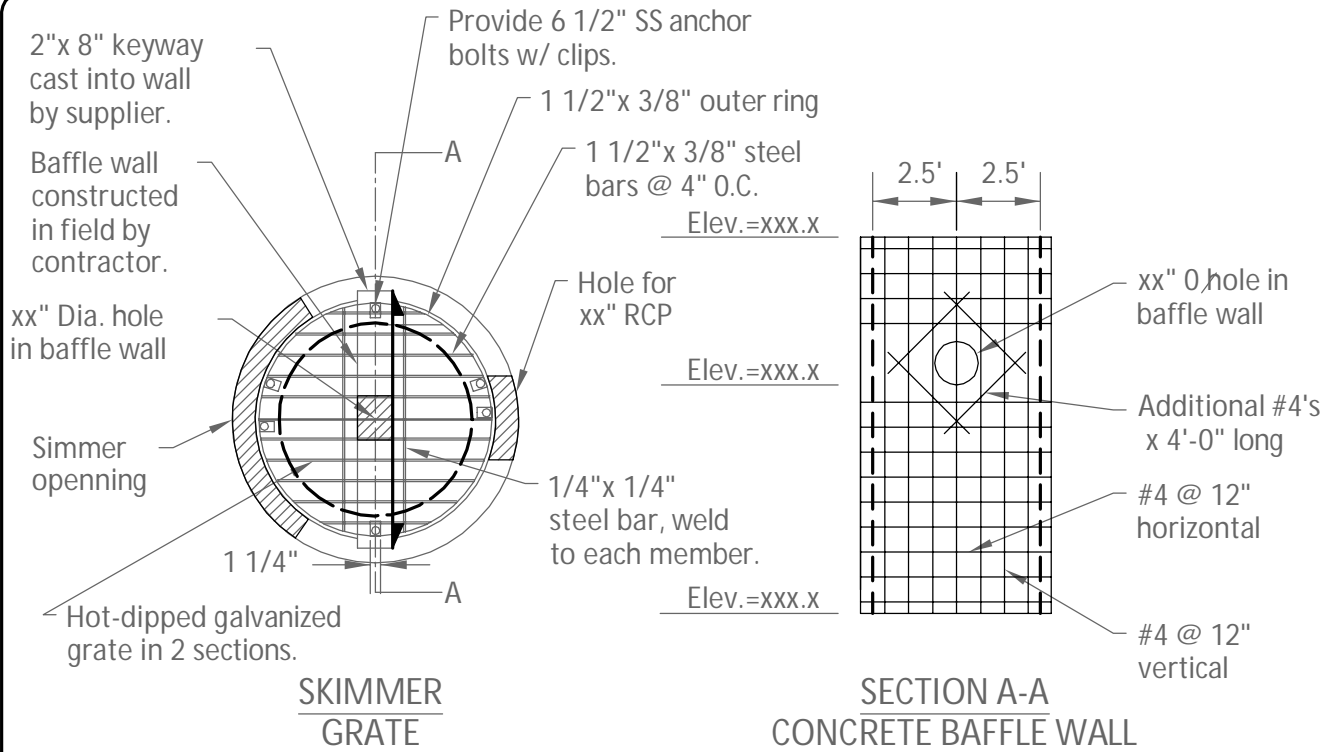

**STANDARD DETAILS**  
**POND OUTLET SKIMMER STRUCTURE**  
**FRIDLEY, MINNESOTA**

LAST REVISION:  
 DEC 2018

CITY PLATE NO.  
 STO-31

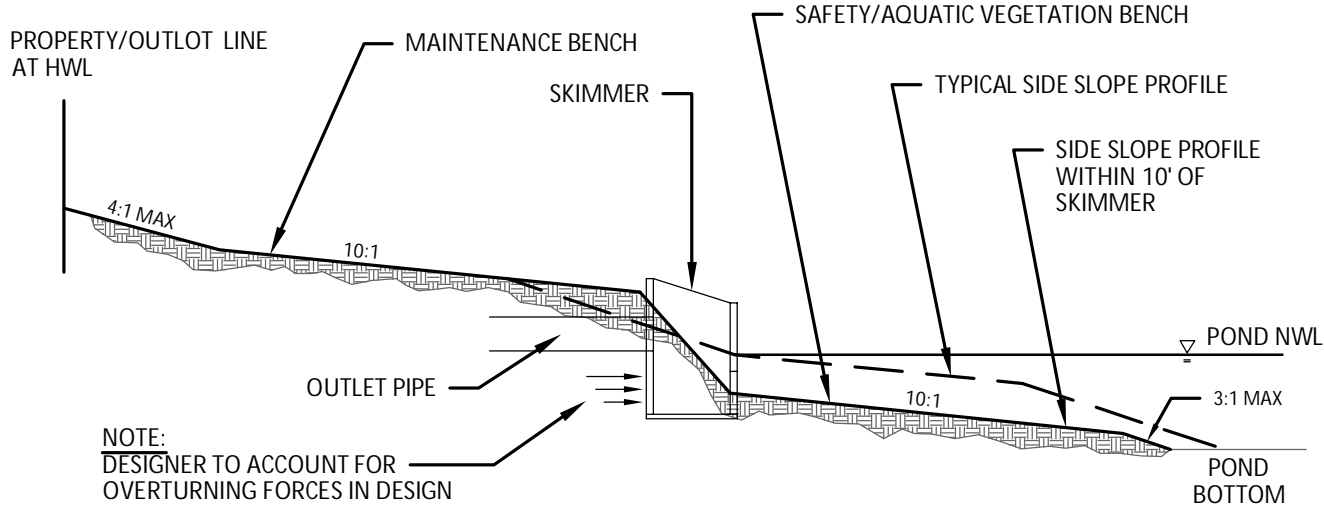

TYPICAL BENCH DETAIL  
WITHIN 10' OF SKIMMER OUTLET

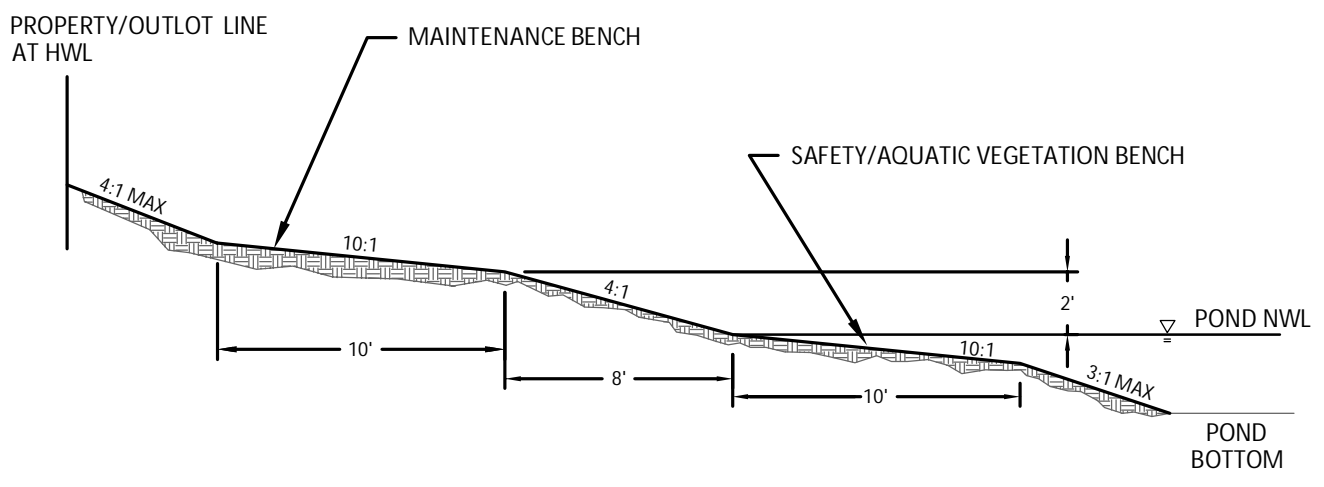

TYPICAL BENCH DETAIL

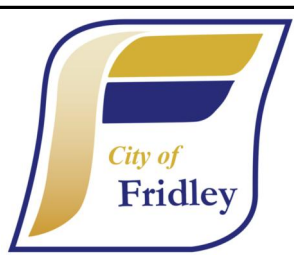

STANDARD DETAILS

TYPICAL BENCH DETAIL

FRIDLEY, MINNESOTA

LAST REVISION:  
DEC 2018

CITY PLATE NO.  
STO-32



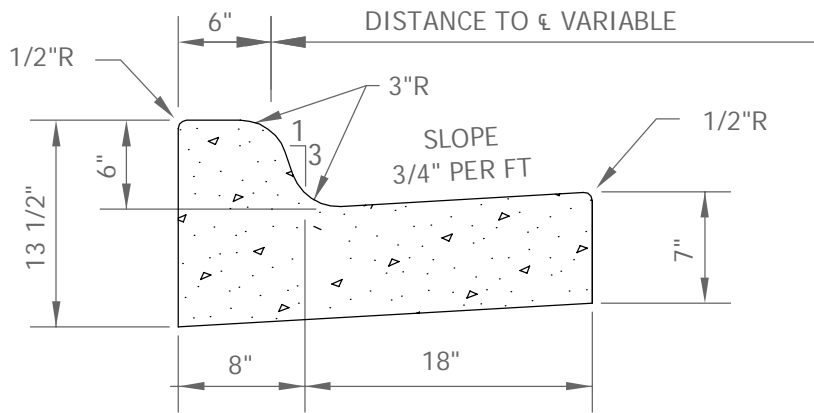

MNDOT B618

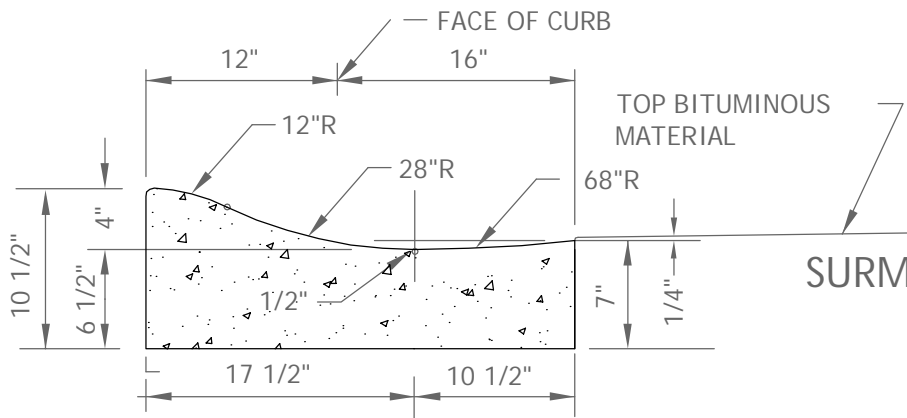

SURMOUNTABLE

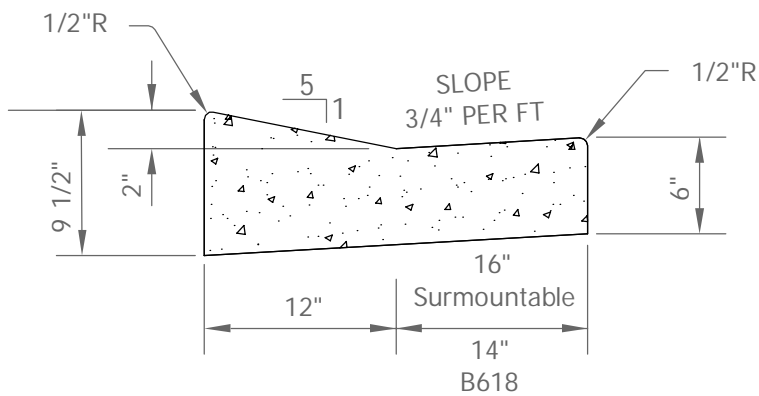

DRIVEWAY

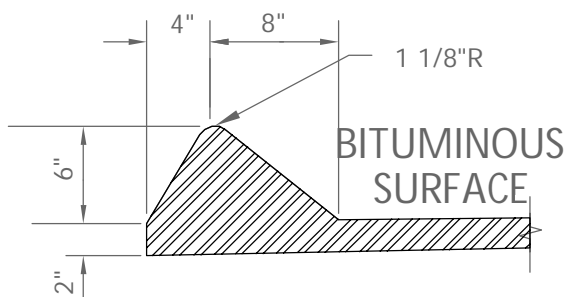

6" SHOE FORMED



STANDARD DETAILS

CURB AND GUTTER

FRIDLEY, MINNESOTA

LAST REVISION:  
DEC 2018

CITY PLATE NO.  
STR-1

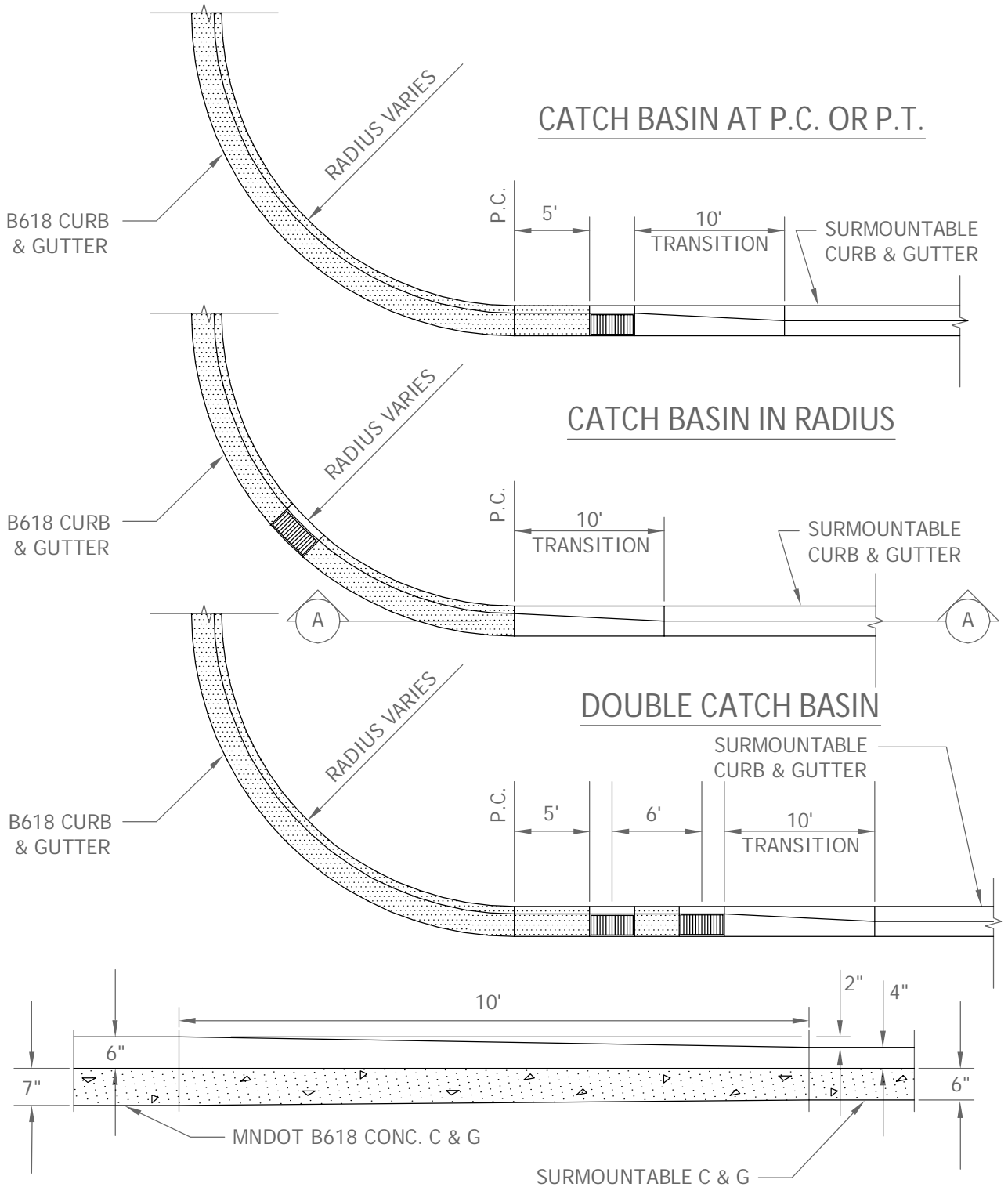

SECTION A-A



STANDARD DETAILS  
CONCRETE CURB & GUTTER

**FRIDLEY, MINNESOTA**

LAST REVISION:  
DEC 2018

CITY PLATE NO.  
STR-2

NOTE:  
 SURMOUNTABLE CURB & GUTTER  
 TO BE FORMED INTO A B618 TYPE  
 AT CATCH BASIN.

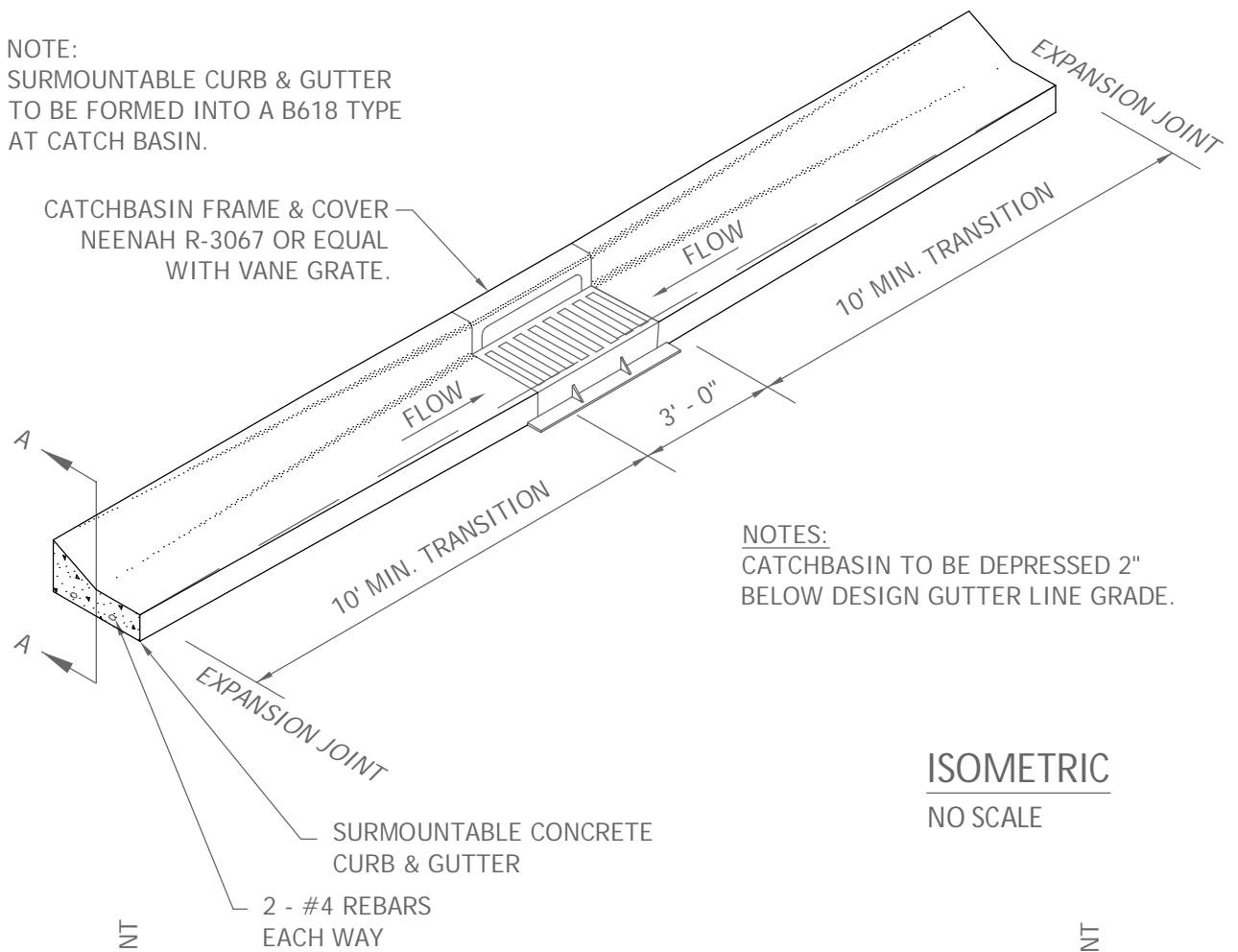

NOTES:  
 CATCHBASIN TO BE DEPRESSED 2"  
 BELOW DESIGN GUTTER LINE GRADE.

ISOMETRIC  
 NO SCALE

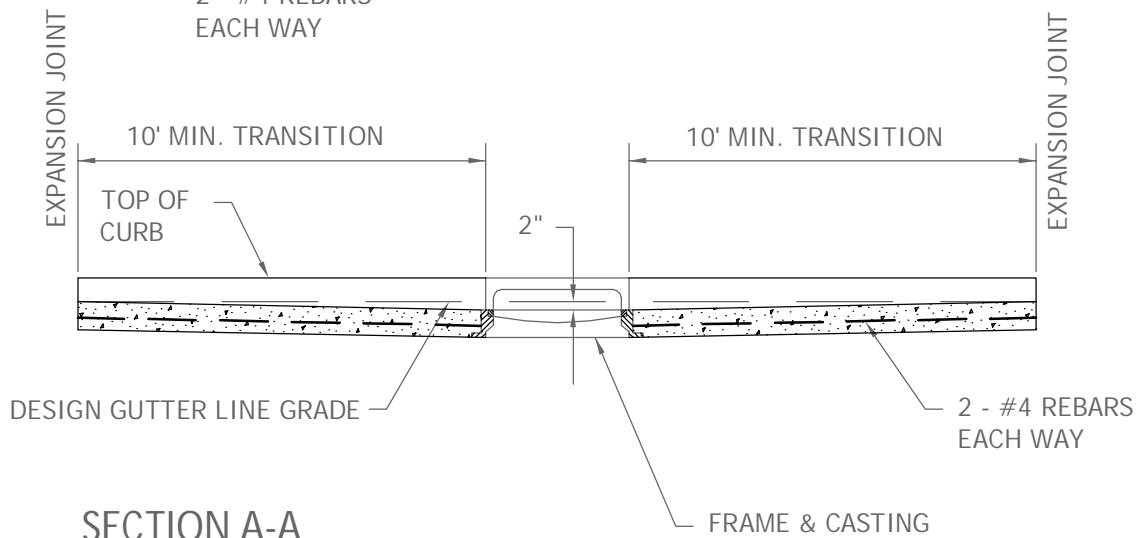

SECTION A-A  
 NO SCALE



STANDARD DETAILS  
 SURMOUNTABLE CURB & GUTTER  
 CONSTRUCTION AT CATCHBASIN

**FRIDLEY, MINNESOTA**

LAST REVISION:  
 DEC 2018

CITY PLATE NO.  
 STR-3

CONCRETE CURB  
AND GUTTER  
(SEE PLATE STR-1)

EXPANSION JOINT

EXPAN. JT.  
PROPERTY LINE, SIDEWALK OR  
EXIST. DRIVEWAY

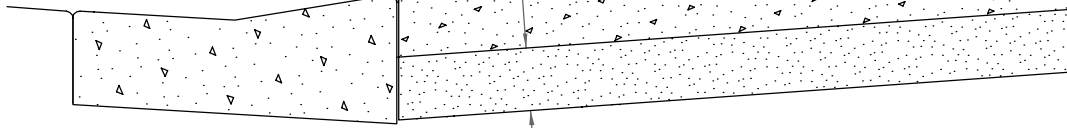

DRIVEWAY SECTION  
NO SCALE

6" AGGREGATE BASE  
CLASS 5

1. PANEL WIDTH SHALL NOT EXCEED 10 FEET WITHOUT A CONTRACTION JOINT.
2. DRIVEWAY TO BE ONE COURSE CONCRETE PAVEMENT.
3. 7" THICK FOR RESIDENTIAL, 8" THICK FOR COMMERCIAL, AND ALLEY OR AS SPECIFIED.
4. DRIVEWAY WIDTH IS 24' UNLESS OTHERWISE NOTED.
5. MINIMUM DISTANCE FROM LOT LINE IS 5'.
6. NEENAH R-1914-A CASTING IS REQUIRED FOR CURBSTOPS LOCATED IN DRIVEWAYS.
7. MAX. CROSS SLOPE OF SIDEWALK THROUGH DRIVEWAY IS 0.02 FT/FT. ADJUST APRON RUNNING SLOPE AS NEEDED.

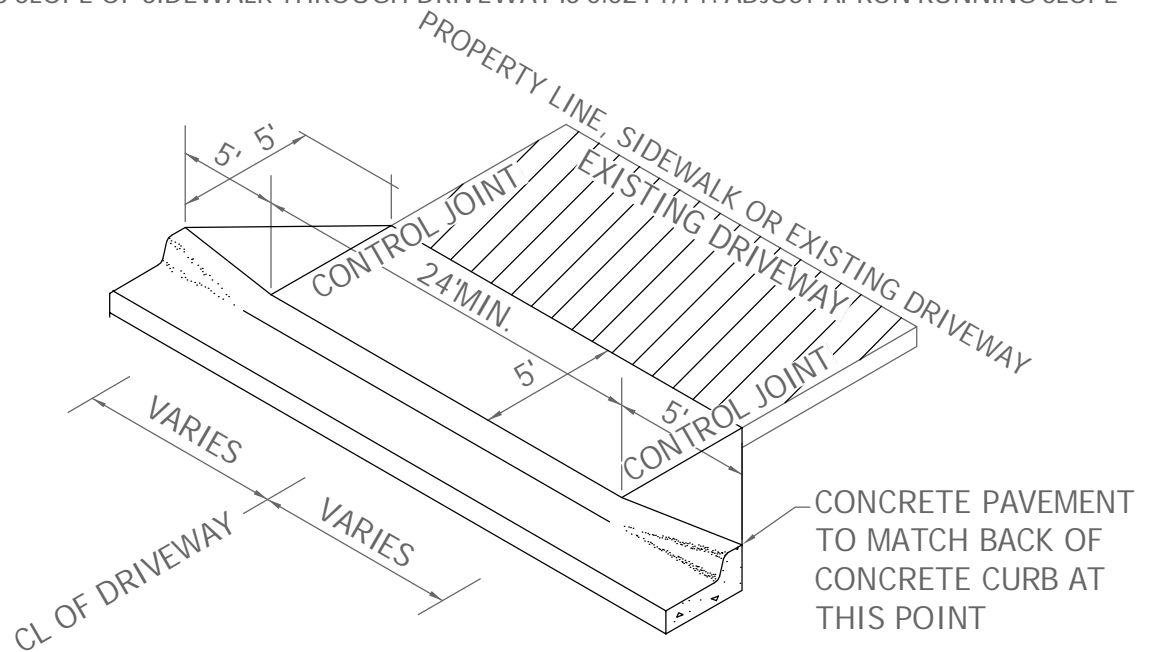

DRIVEWAY  
ISOMETRIC

NOTE:  
CONTROL JOINTS IN CONCRETE CURB  
NOT TO EXCEED 10' SPACING  
THROUGH DRIVEWAY SECTION.



STANDARD DETAILS

CONCRETE DRIVEWAY APRON

FRIDLEY, MINNESOTA

LAST REVISION:  
DEC 2018

CITY PLATE NO.  
STR-4

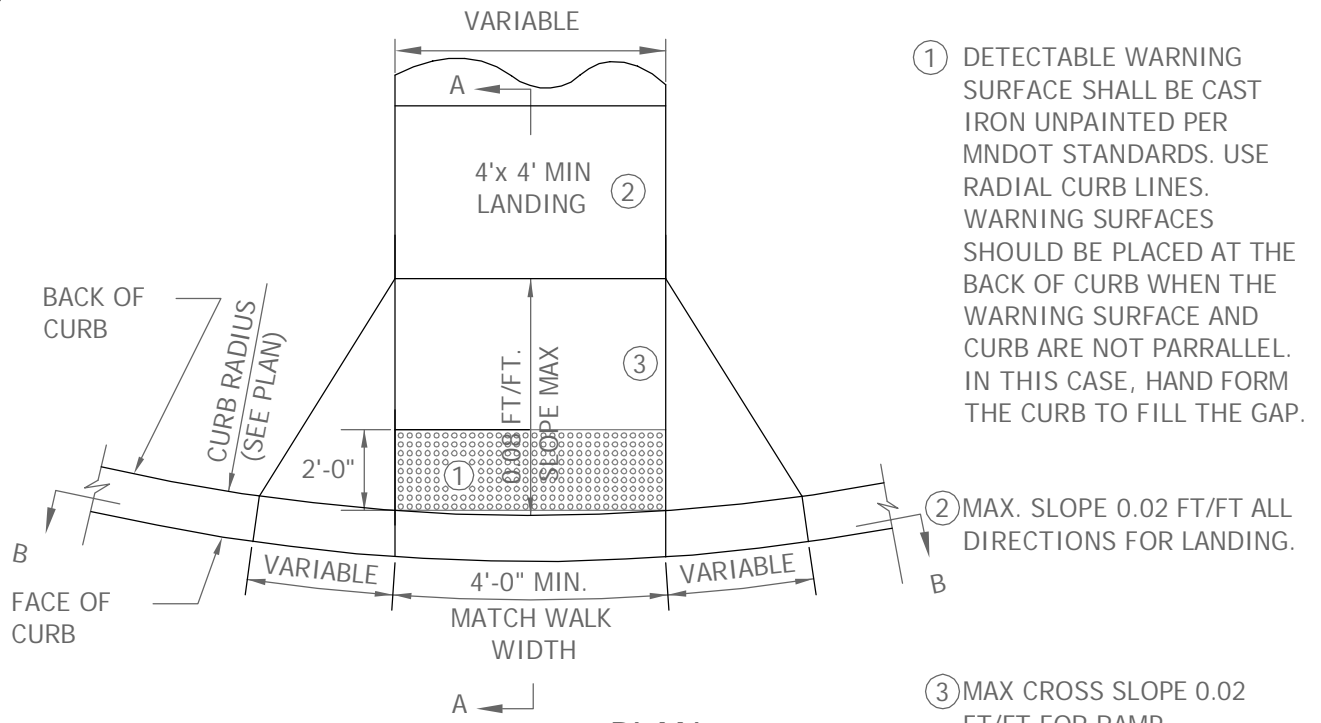

**PLAN**

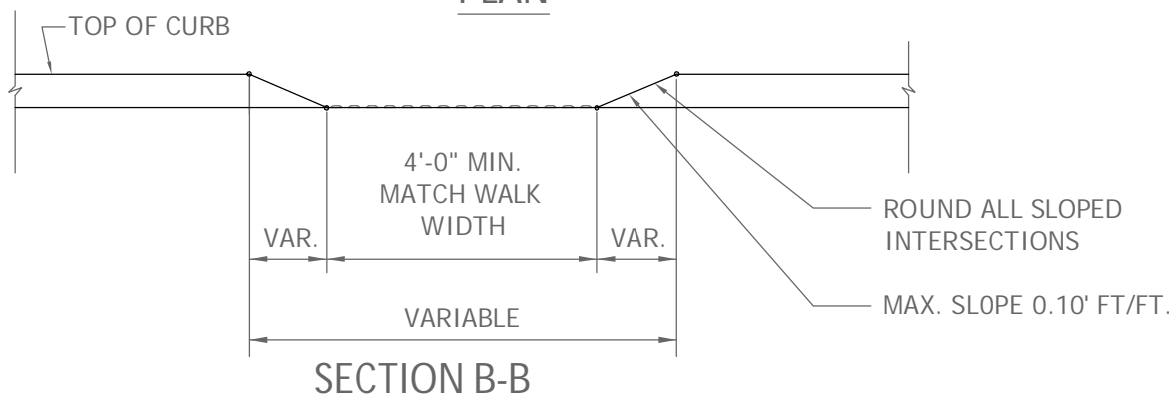

**SECTION B-B**

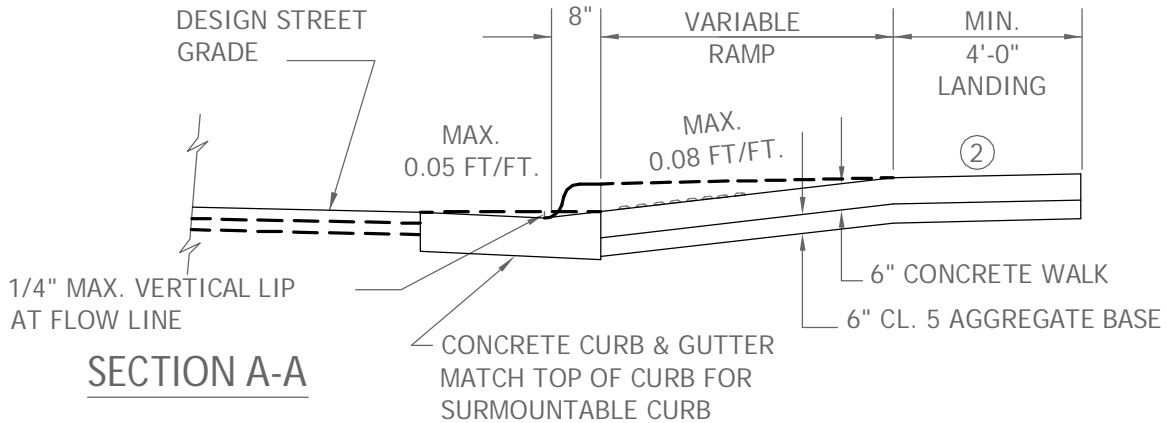

**SECTION A-A**



**STANDARD DETAILS**  
**PEDESTRIAN CURB RAMP**

**FRIDLEY, MINNESOTA**

LAST REVISION:  
DEC 2018

CITY PLATE NO.  
STR-7



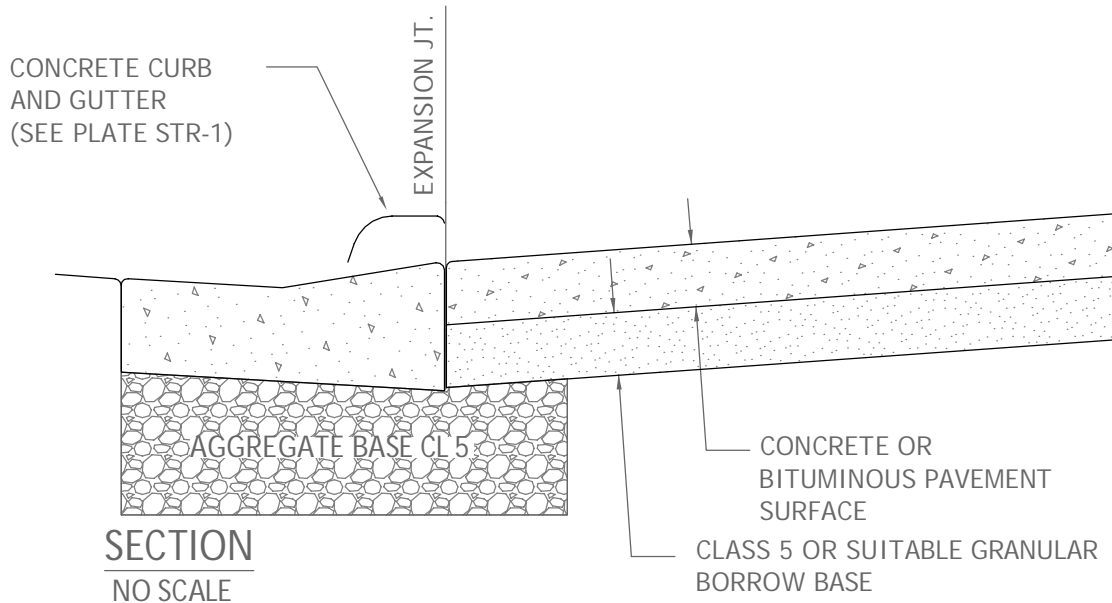

**SECTION**  
NO SCALE

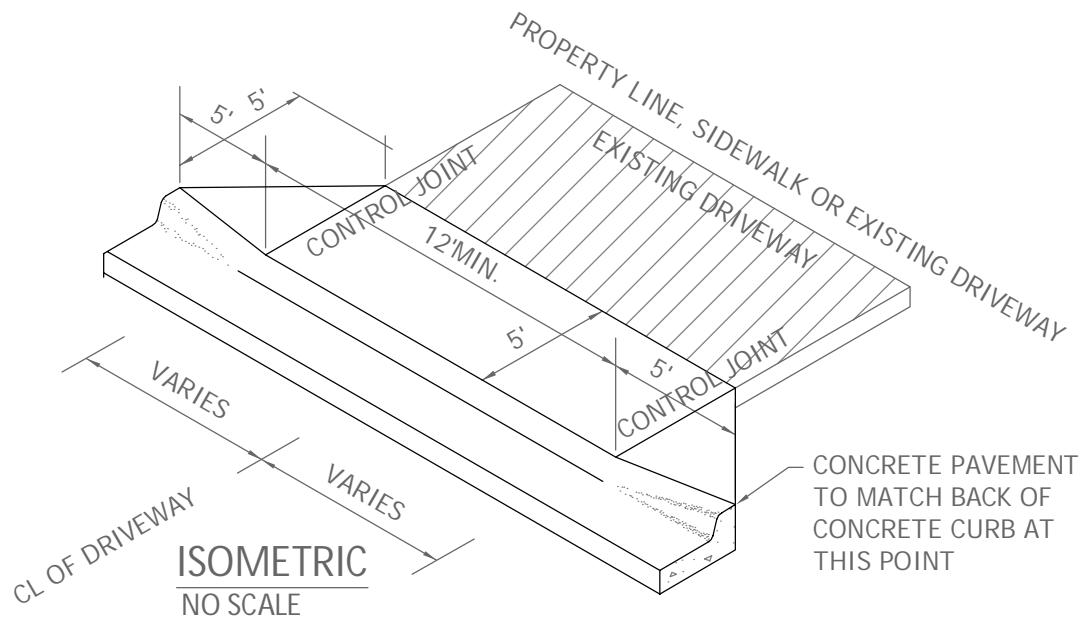

**ISOMETRIC**  
NO SCALE

**NOTE:**

1. CONTROL JOINTS IN CONCRETE CURB NOT TO EXCEED 10' SPACING THROUGH DRIVEWAY SECTION.
2. ALL DRIVEWAYS MUST BE AT LEAST 5 FEET FROM THE PROPERTY LINE AND AT LEAST 30 FEET FROM A STREET RIGHT -OF-WAY.
3. ONLY ONE DRIVEWAY ENTRANCE PER PARCEL UNLESS OTHERWISE APPROVED BY CITY.
4. NEENAH R-1914-A CASTING IS REQUIRED FOR CURB STOPS LOCATED IN DRIVEWAYS.
5. MAX. CROSS SLOPE OF SIDEWALK THROUGH DRIVEWAY IS 0.02 FT/FT. ADJUST APRON RUNNING SLOPE AS NEEDED.



**STANDARD DETAILS**

URBAN RESIDENTIAL DRIVEWAY APRON

**FRIDLEY, MINNESOTA**

LAST REVISION:  
DEC 2018

CITY PLATE NO.  
STR-9

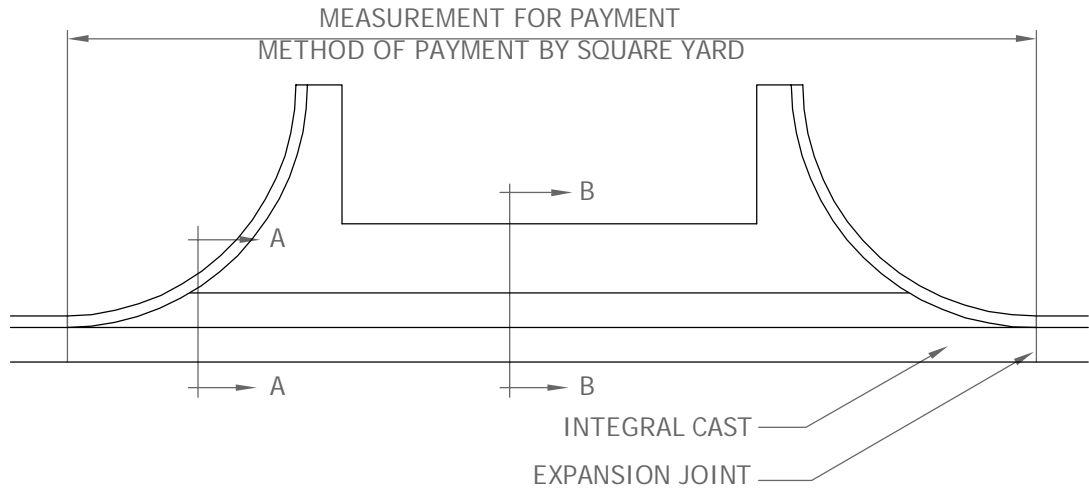

NOTE:  
TIP OUT GUTTER AND HIGH POINTS DETERMINED IN FIELD BY ENGINEER

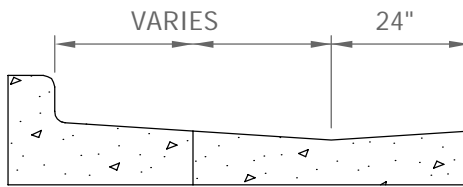

SECTION A-A THRU  
B618 C & G

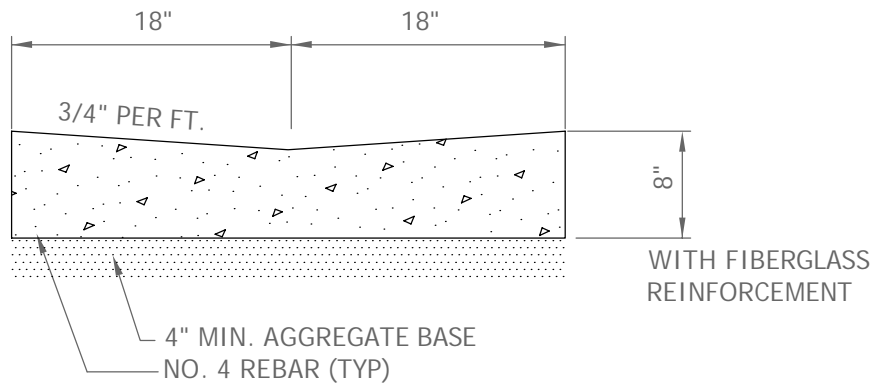

SECTION B-B  
THRU CONCRETE GUTTER



STANDARD DETAILS  
CONCRETE VALLEY GUTTER

FRIDLEY, MINNESOTA

LAST REVISION:  
DEC 2018

CITY PLATE NO.  
STR-10

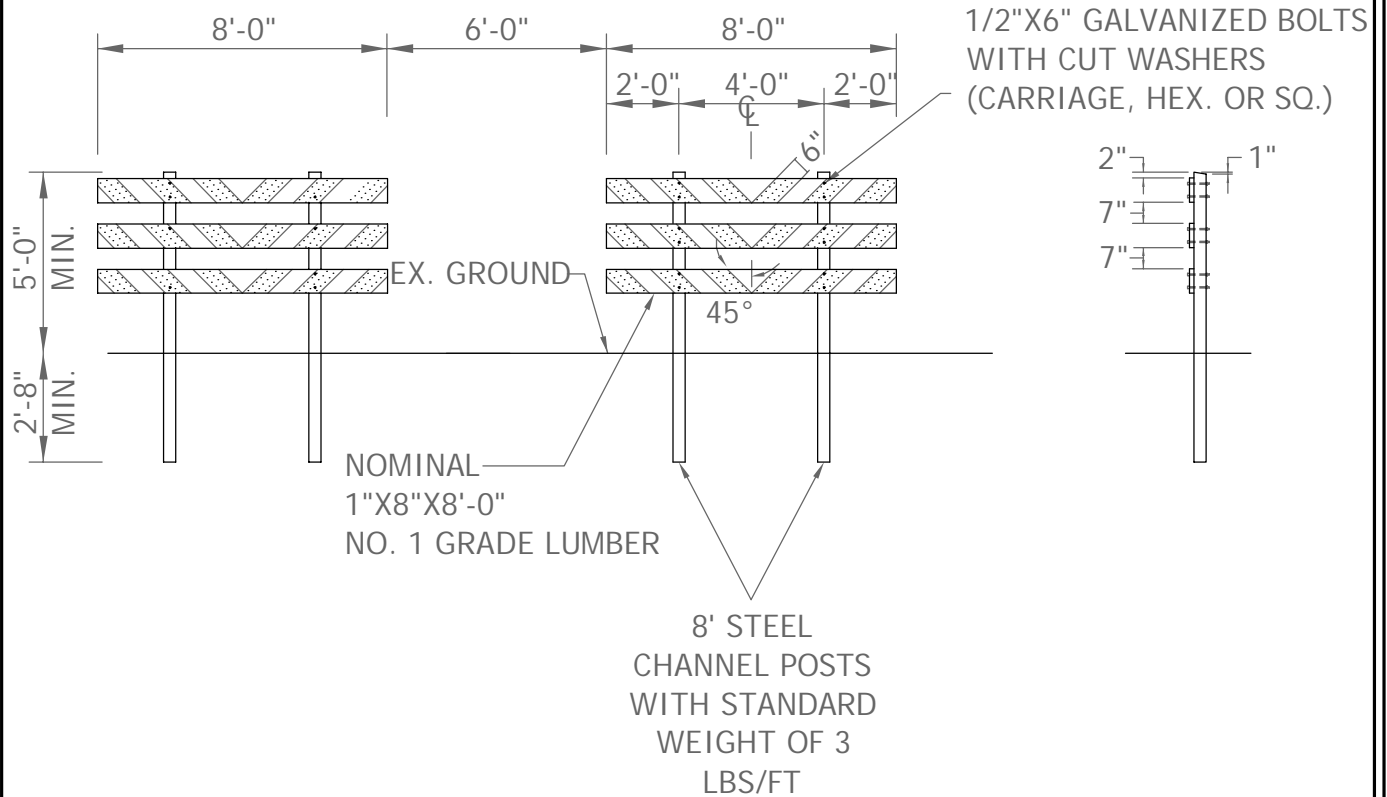

NOTES:

1. THE BARRICADE BOARD FACE SURFACES SHALL BE FULLY REFLECTORIZED IN ALTERNATE SILVER-WHITE AND RED STRIPING, USING A REFLECTIVE SHEETING CONFORMING TO THE REQUIREMENTS OF SPEC 3352.2A2b, STANDARD NO. 2.
2. PRIOR TO INSTALLING THE REFLECTIVE SHEETING, THE BARRICADE BOARDS SHALL BE GIVEN A COMPLETE COATING OF WHITE WOOD PRIMER PAINT, FOLLOWED BY A SECOND COAT OF WHITE GUARD RAIL PAINT CONFORMING TO CURRENT MNDOT SPECIFICATIONS, APPLIED ONLY TO THE SURFACES NOT COVERED WITH REFLECTIVE SHEETING.
3. THE BARRICADE BOARDS SHALL BE COMPLETELY PAINTED AND REFLECTORIZED SHEETING APPLIED BEFORE BEING INSTALLED ON THE POSTS.
4. THE PLACEMENT OF THE BARRICADES SHALL BE 10'-0" FROM THE END OF THE BITUMINOUS ROAD WITH THE BARRICADE CENTERED ON THE ROADWAY FACING THE OF TRAFFIC.



STANDARD DETAILS

DOUBLE PERMANENT BARRICADE

FRIDLEY, MINNESOTA

LAST REVISION:  
DEC 2018

CITY PLATE NO.  
STR-11



MULTI-LANE - MORE THAN 40MPH



MULTI-LANE - 40MPH OR LESS  
2 LANE - ALL SPEED LIMITS

STANDARD CONSTRUCTION NOTES FOR STREET NAME SIGNS:

1. ALL STREET SIGNS SHALL BE DIAMOND GRADE DG3, DOUBLE-FACED EXTRUDED BLADES.
2. ADDRESS NUMBERS FOR STREET NAME BLADES WILL BE PROVIDED AT A LATER DATE.
3. CONTRACTOR SHALL SUBMIT SHOP DRAWINGS FOR STREET NAME BLADES PRIOR TO FABRICATION.
4. STREET SIGN POSTS SHALL BE 12 FEET LONG, 4 FEET DRIVEN INTO THE GROUND.
5. SIGN POSTS FOR STREET NAME BLADES SHALL BE ROUND TUBULAR ALUMINUM OR HOT DIPPED GALVANIZED STEEL, OUTSIDE DIAMETER 2-3/8 INCHES, WALL THICKNESS 0.109 INCHES.
6. SIGN LOCATIONS SHALL BE STAKED BY THE ENGINEER AT THE TIME OF CONSTRUCTION.
7. ALL NORTH / SOUTH NAME BLADES SHALL BE "GREEN" IN COLOR. LETTERING ON ALL STREET NAME BLADES SHALL BE DIAMOND GRADE DG3, "WHITE" IN COLOR.



STANDARD DETAILS  
 STREET NAME BLADE SIGNS  
 PUBLIC STREETS

**FRIDLEY, MINNESOTA**

LAST REVISION:  
 MAR 2019

CITY PLATE NO.  
 STR-19



MULTI-LANE - MORE THAN 40MPH



MULTI-LANE - 40MPH OR LESS  
2 LANE - ALL SPEED LIMITS

**STANDARD CONSTRUCTION NOTES FOR STREET NAME SIGNS:**

1. ALL STREET SIGNS SHALL BE DIAMOND GRADE DG3, DOUBLE-FACED EXTRUDED BLADES.
2. CONTRACTOR SHALL SUBMIT SHOP DRAWINGS FOR STREET NAME BLADES PRIOR TO FABRICATION.
3. STREET SIGN POSTS SHALL BE 12 FEET LONG, 4 FEET DRIVEN INTO THE GROUND.
4. SIGN POSTS FOR STREET NAME BLADES SHALL BE ROUND TUBULAR ALUMINUM OR HOT DIPPED GALVANIZED STEEL, OUTSIDE DIAMETER 2-3/8 INCHES, WALL THICKNESS 0.109 INCHES.
5. SIGN LOCATIONS SHALL BE STAKED BY THE ENGINEER AT THE TIME OF CONSTRUCTION.
6. ALL EAST / WEST PRIVATE STREET NAME BLADES SHALL BE "BLUE" IN COLOR. LETTERING ON ALL STREET NAME BLADES SHALL BE DIAMOND GRADE DG3, "WHITE" IN COLOR.



**STANDARD DETAILS**  
**STREET NAME BLADE SIGNS**  
**PRIVATE STREETS**

**FRIDLEY, MINNESOTA**

LAST REVISION:  
**MAR 2019**

CITY PLATE NO.  
**STR-20**

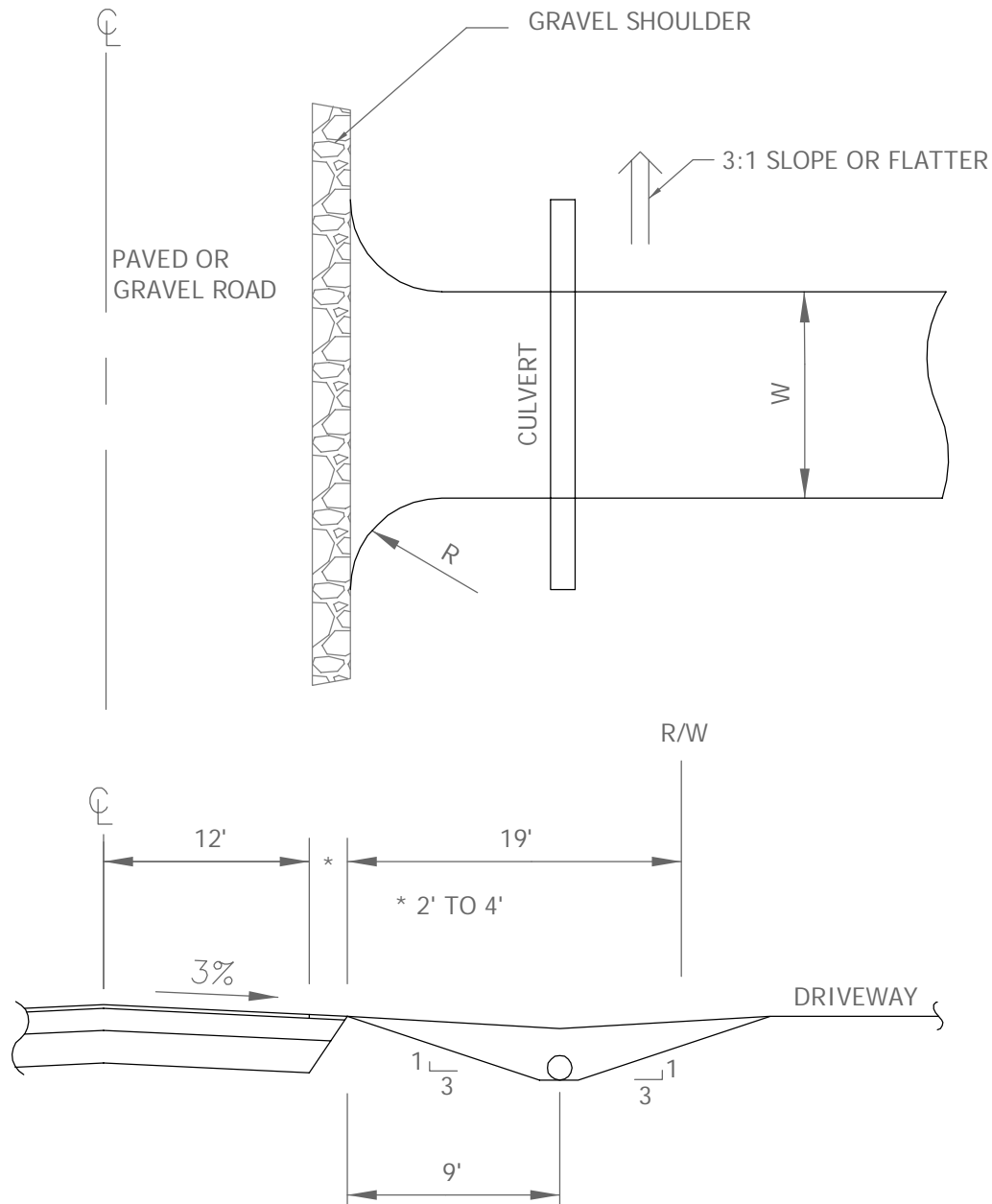

**NOTES:**

1. DRIVEWAY WIDTH (W): 12' MIN., 22' MAX.
2. RADIUS AT CONNECTION TO STREET (R): 5' MIN., 15' MAX.
3. CULVERT UNDER DRIVEWAY: MIN. 15" DIA., CMP OR RCP
4. DRIVEWAY SLOPES GREATER THAN 6% SHALL BE PAVED TO PREVENT EROSION.
5. MAINTAIN 60' MIN. CLEARANCE FROM EDGE OF DRIVEWAY TO R/W LINE OF ADJACENT STREET INTERSECTION.
6. CULVERT FLARED ENDS ARE REQUIRED.
7. MINIMUM 1% GRADE ON CULVERTS.
8. HOMEOWNER IS RESPONSIBLE FOR CULVERT INSTALLATION AND ESTABLISHMENT OF VEGETATION ALONG DRIVEWAY.



**STANDARD DETAILS**  
**TYPICAL DRIVEWAY &**  
**CULVERT INSTALLATION**

**FRIDLEY, MINNESOTA**

LAST REVISION:  
 DEC 2018

CITY PLATE NO.  
 STR-21

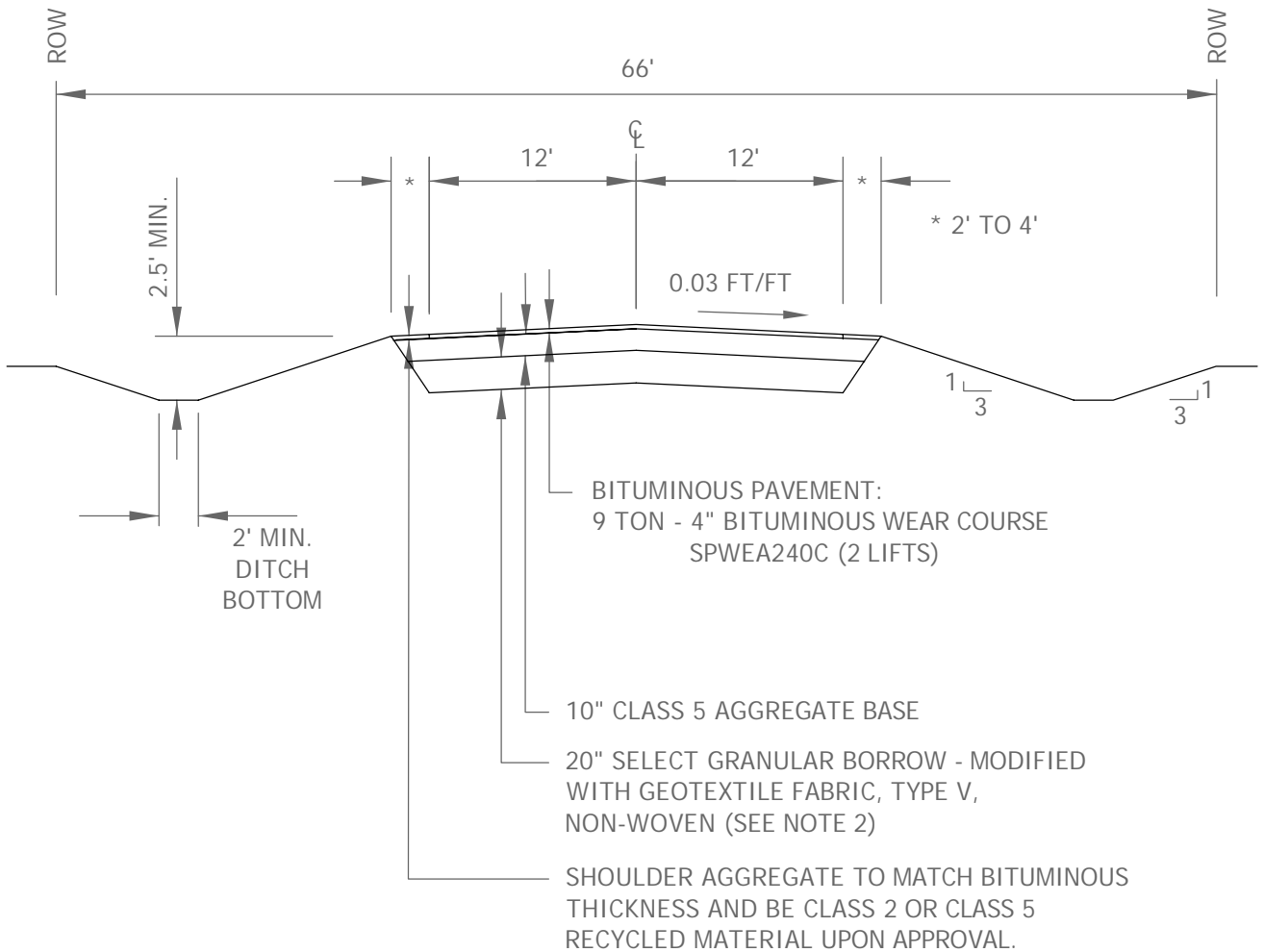

NOTES:

1. ALL ORGANIC OR OTHER UNSUITABLE MATERIAL SHALL BE REMOVED FROM BENEATH THE ROADWAY.
2. A TEST ROLL OF THE PREPARED SUBGRADE SHALL BE PERFORMED IN THE PRESENCE OF A CITY INSPECTOR. THE CITY HAS THE AUTHORITY TO REQUIRE ADDITIONAL SUBGRADE CORRECTION AND GRANULAR BORROW, OR ELIMINATE THE STABILIZATION FABRIC AND GRANULAR BORROW.



STANDARD DETAILS

TYPICAL RURAL ROAD SECTION

**FRIDLEY, MINNESOTA**

LAST REVISION:  
DEC 2018

CITY PLATE NO.  
STR-22

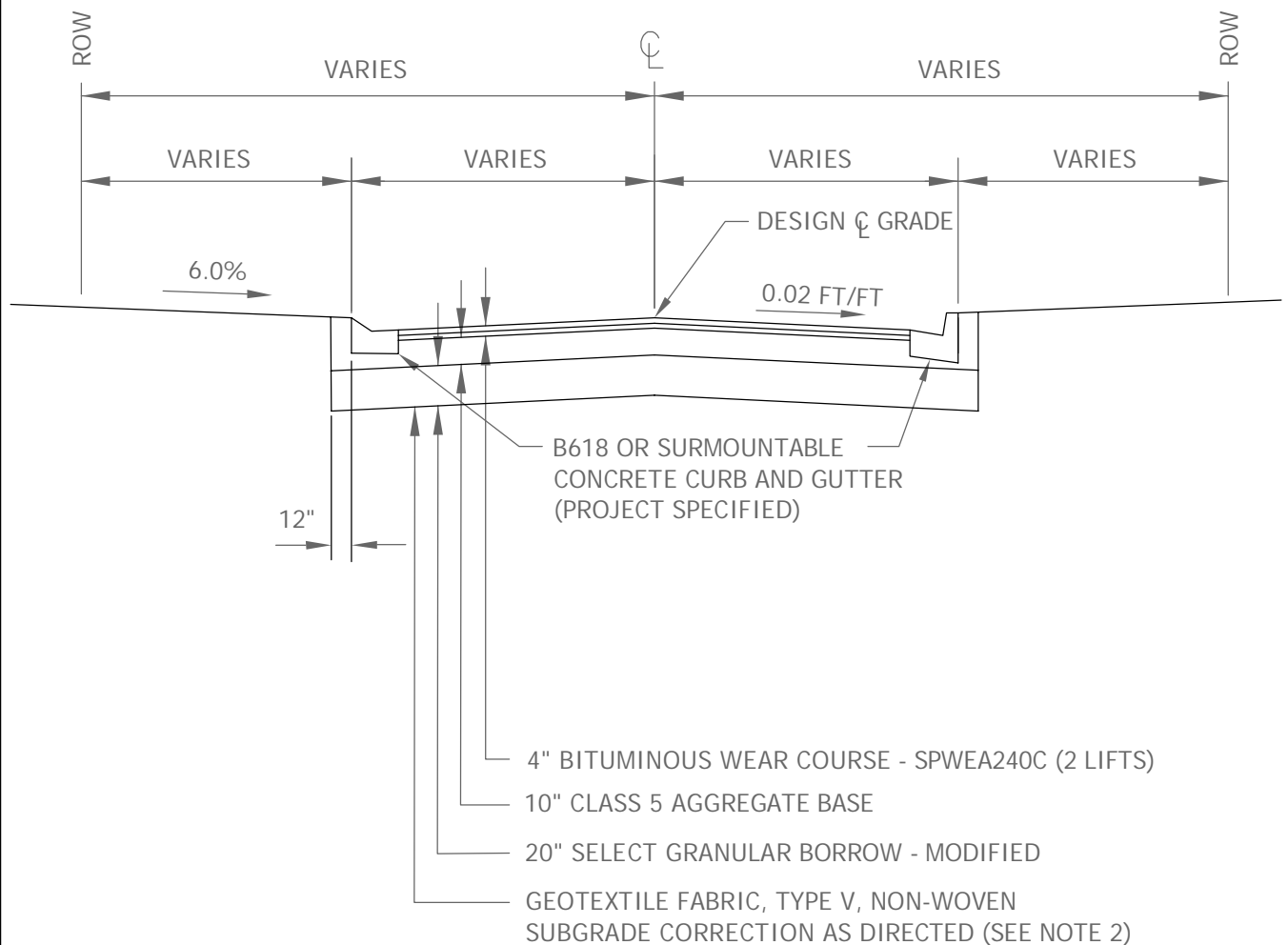

NOTES:

1. ALL ORGANIC OR OTHER UNSUITABLE MATERIAL SHALL BE REMOVED FROM BENEATH THE ROADWAY.
2. A TEST ROLL OF THE PREPARED SUBGRADE SHALL BE PERFORMED IN THE PRESENCE OF A CITY INSPECTOR. THE CITY HAS THE AUTHORITY TO REQUIRE ADDITIONAL SUBGRADE CORRECTION AND GRANULAR BORROW, OR ELIMINATE THE STABILIZATION FABRIC AND GRANULAR BORROW.
3. DRAINTILE IS REQUIRED BEHIND CURB, MINIMUM 50' EACH WAY FROM CATCH BASINS.



STANDARD DETAILS

TYPICAL URBAN ROAD SECTION

**FRIDLEY, MINNESOTA**

LAST REVISION:  
DEC 2018

CITY PLATE NO.  
STR-22A



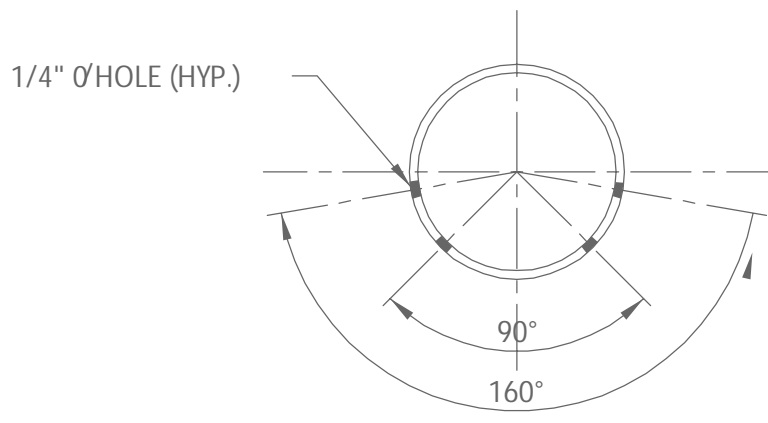
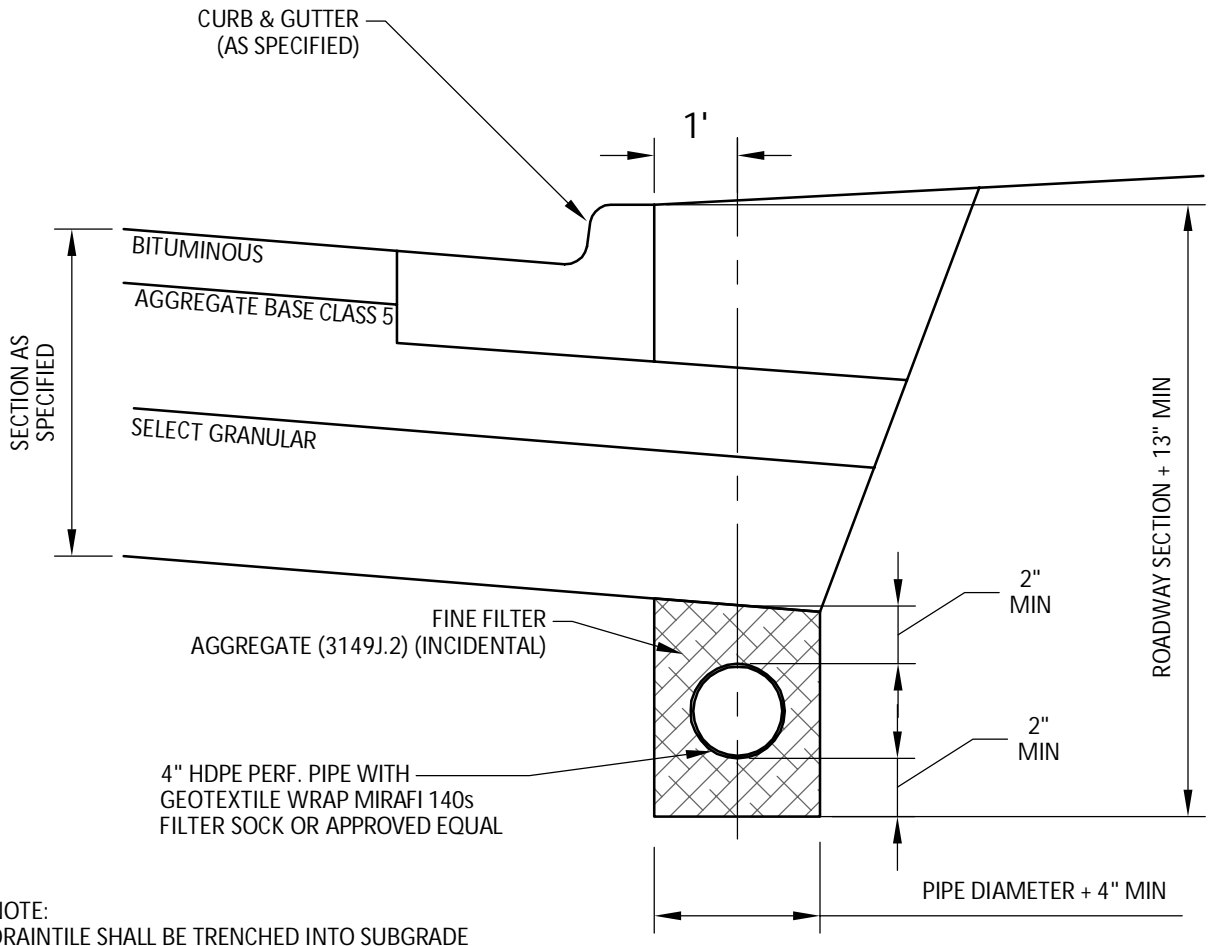

4" PERFORATED HDPE WITH GEOTEXTILE WRAP MIRAFI 140s FILTER SOCK OR EQUAL.

PIPE DETAIL



STANDARD DETAILS  
TYPICAL URBAN ROAD SECTION  
EDGE DRAIN

**FRIDLEY, MINNESOTA**

LAST REVISION:  
DEC 2018

CITY PLATE NO.  
STR-22B

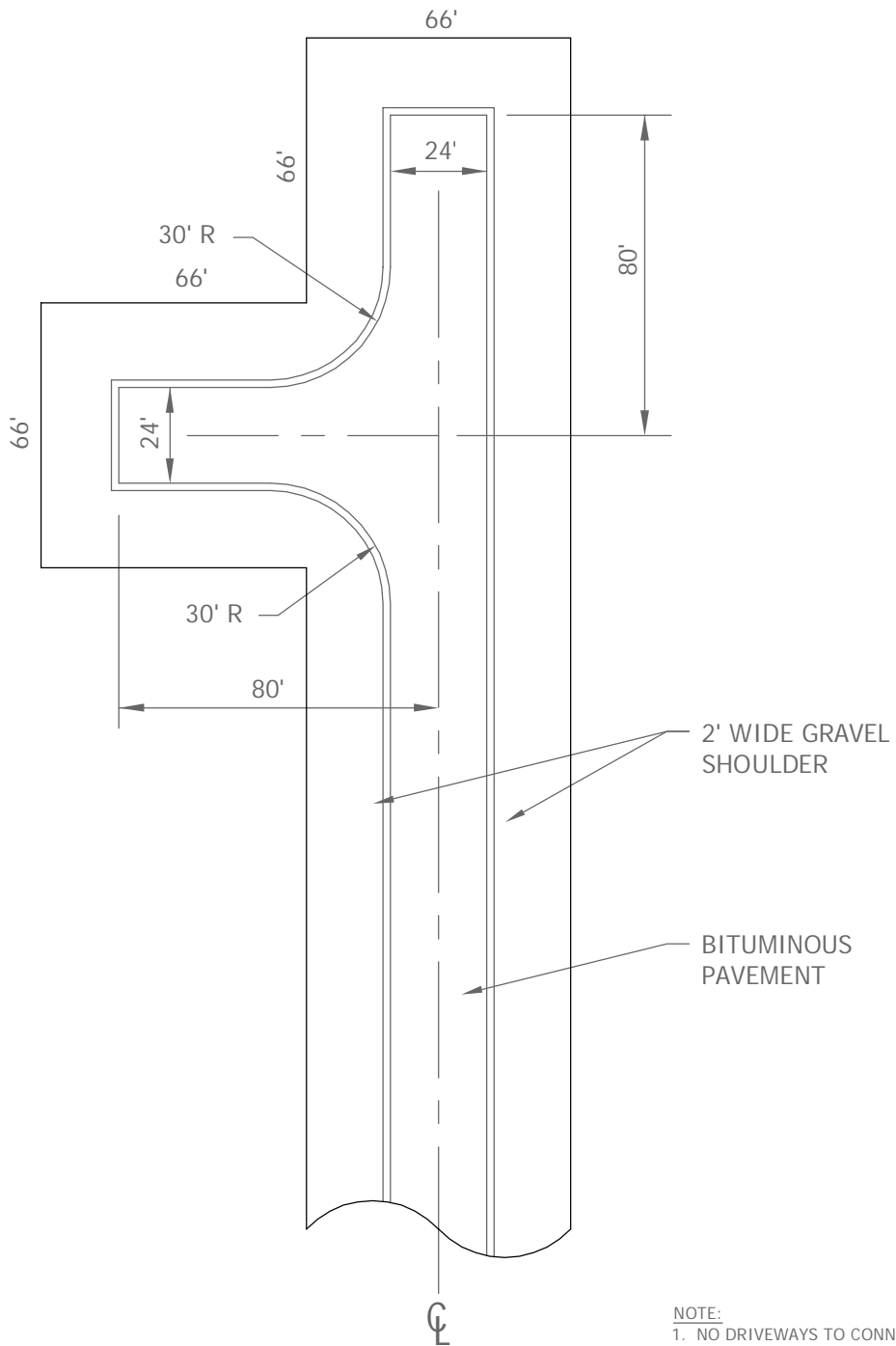

NOTE:

1. NO DRIVEWAYS TO CONNECT TO ENDS OF EITHER LEG.
2. ALL TURNAROUNDS SHALL BE TO THE LEFT, AS SHOWN.



STANDARD DETAILS  
 TYPICAL STREET TURNAROUND  
 RURAL SECTION

**FRIDLEY, MINNESOTA**

LAST REVISION:  
 DEC 2018

CITY PLATE NO.  
 STR-23

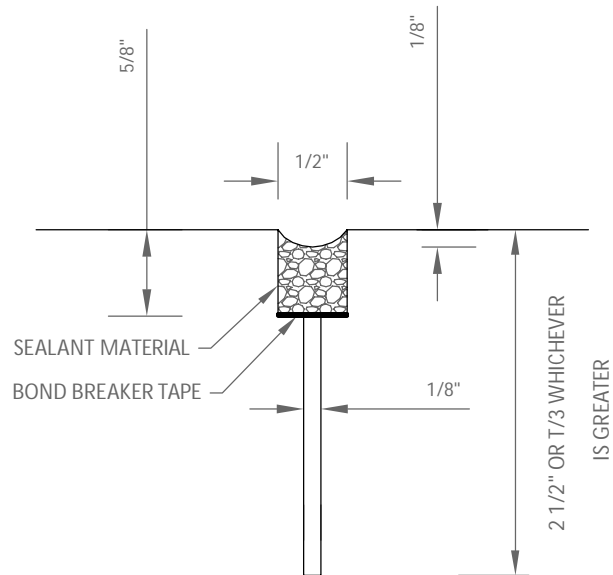

T/3 = ONE THIRD THE TOTAL OVERLAY THICKNESS (OVERLAY PROJECTS) OR ONE THIRD THE TOTAL BITUMINOUS THICKNESS (NEW CONSTRUCTION PROJECTS)

### TYPICAL JOINT SECTION

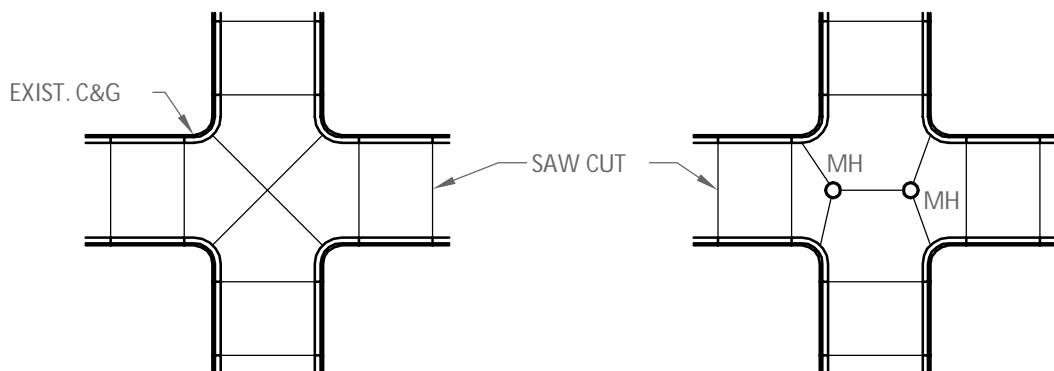

FIGURE 2.  
NO MANHOLES IN THE INTERSECTION

FIGURE 3.  
TWO MANHOLES IN THE INTERSECTION

SAW AND SEAL IN URBAN SECTIONS:  
WHEN USING SAW AND SEAL IN AN URBAN SETTING WHERE CURB AND GUTTER IS PRESENT THE SAW CUTS SHOULD LINE UP WITH THE CONTROL JOINTS IN THE GUTTER SECTIONS WHENEVER POSSIBLE, EVEN IF THIS RESULTS IN A SLIGHTLY SKEWED JOINT AS SHOWN IN FIGURES 2 AND 3.

IN INTERSECTIONS, SAWING SHOULD BE SIMILAR TO FIGURES 2 OR 3 DEPENDING ON WHETHER MANHOLES ARE PRESENT.



## STANDARD DETAILS BITUMINOUS SAW & SEAL

# FRIDLEY, MINNESOTA

LAST REVISION:  
DEC 2018

CITY PLATE NO.  
SAN-24

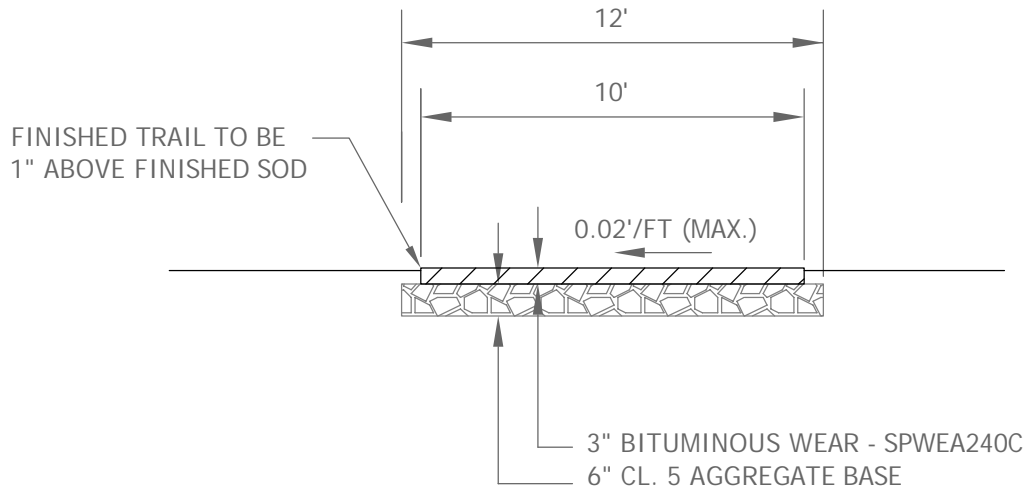

TYPICAL TRAIL SECTION

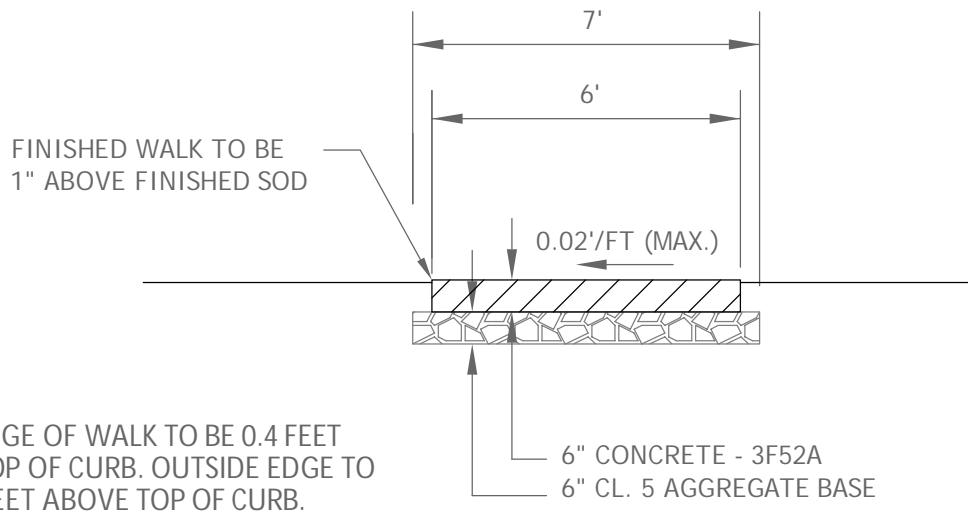

NOTE:  
INSIDE EDGE OF WALK TO BE 0.4 FEET ABOVE TOP OF CURB. OUTSIDE EDGE TO BE 0.52 FEET ABOVE TOP OF CURB.

CONCRETE SIDEWALK



STANDARD DETAILS  
TYPICAL BITUMINOUS TRAIL  
AND CONCRETE SIDEWALK

**FRIDLEY, MINNESOTA**

LAST REVISION:  
DEC 2018

CITY PLATE NO.  
STR-25

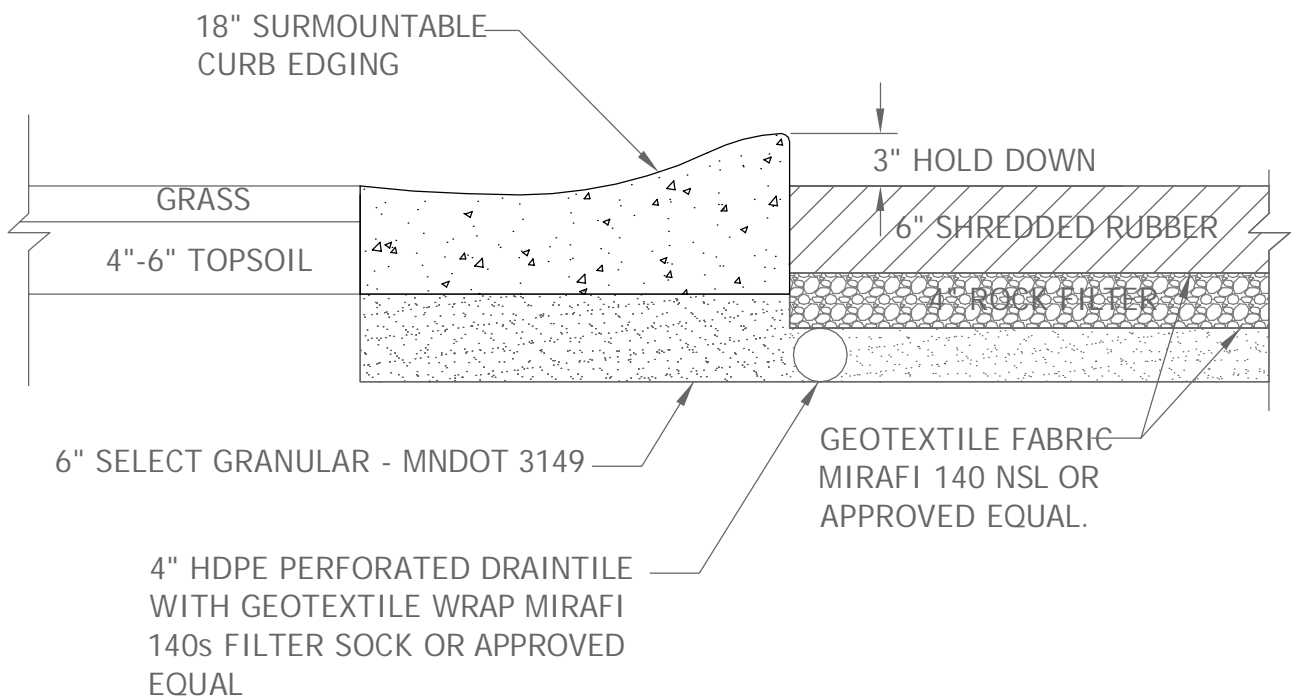

STANDARD DETAILS  
PLAYGROUND PLAY AREA

FRIDLEY, MINNESOTA

LAST REVISION:  
DEC 2018

CITY PLATE NO.  
STR-26

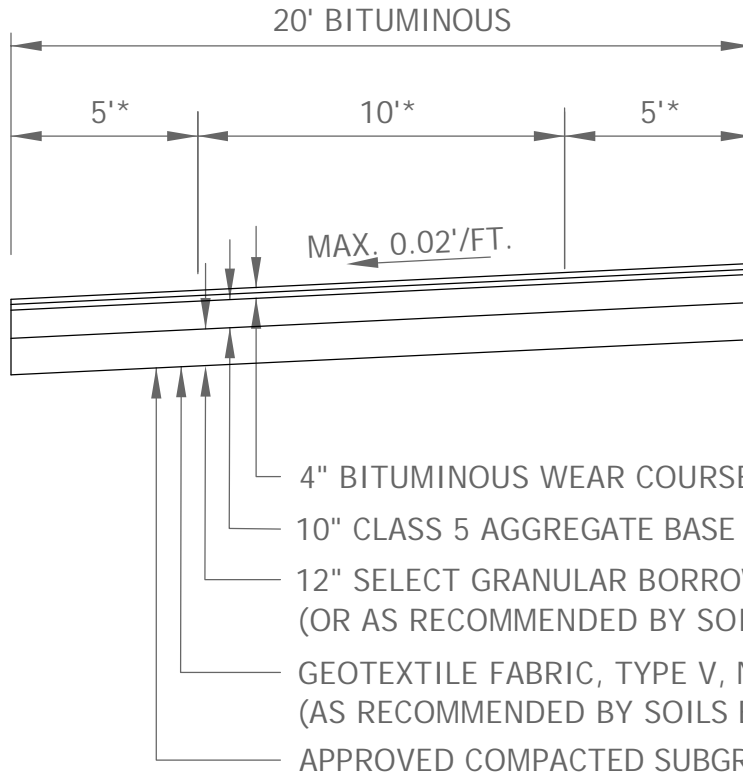

\* OPTION: 10' WIDE BITUMINOUS, WITH 5' WIDE GRAVEL SHOULDERS. GRAVEL SECTION MUST BE INCREASED 4" UNDER SHOULDERS TO PROVIDE EQUIVALENT STRUCTURAL SUPPORT FOR SHOULDERS.

TYPICAL SECTION

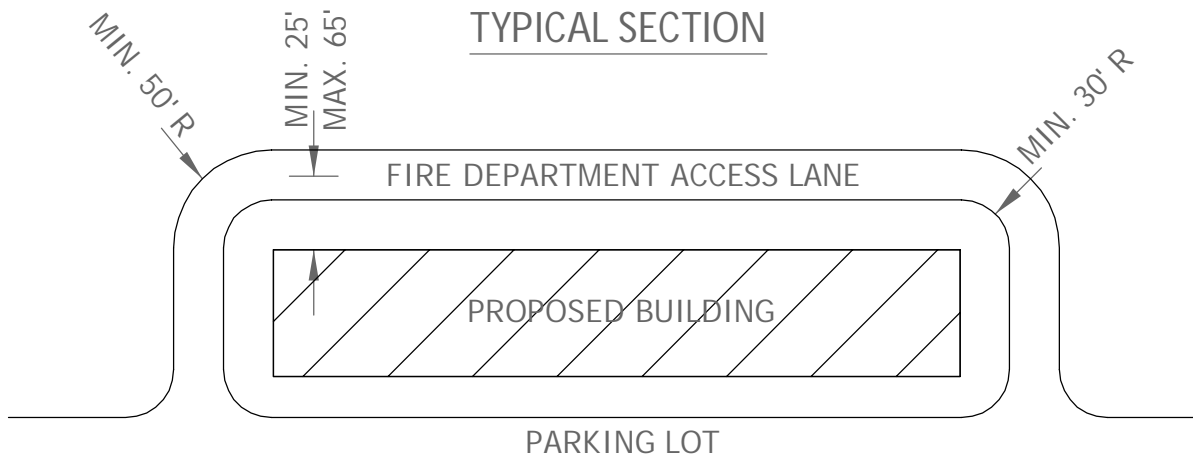

PLAN VIEW

NOTES:

1. DEAD END ACCESS LANES OVER 150' IN LENGTH NEED AN APPROVED TURNAROUND.
2. UNOBSTRUCTED VERTICAL CLEARANCE OF 13'-6" REQUIRED ABOVE ACCESS LANE.
3. PROVIDE FIRE DEPARTMENT APPROVED SIGNS WITHIN 20' OF EVERY ENTRANCE POINT.



STANDARD DETAILS  
 FIRE DEPARTMENT ACCESS LANE  
 BUILDINGS UP TO 24' HIGH

**FRIDLEY, MINNESOTA**

LAST REVISION:  
 DEC 2018

CITY PLATE NO.  
 STR-27

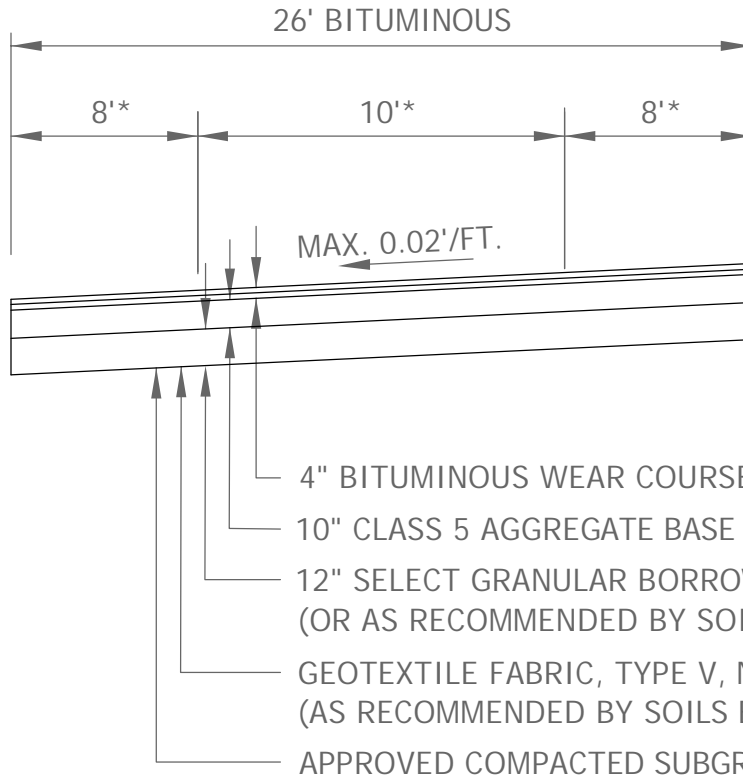

\* OPTION: 10' WIDE BITUMINOUS, WITH 8' WIDE GRAVEL SHOULDERS. GRAVEL SECTION MUST BE INCREASED 4" UNDER SHOULDERS TO PROVIDE EQUIVALENT STRUCTURAL SUPPORT FOR SHOULDERS.

TYPICAL SECTION

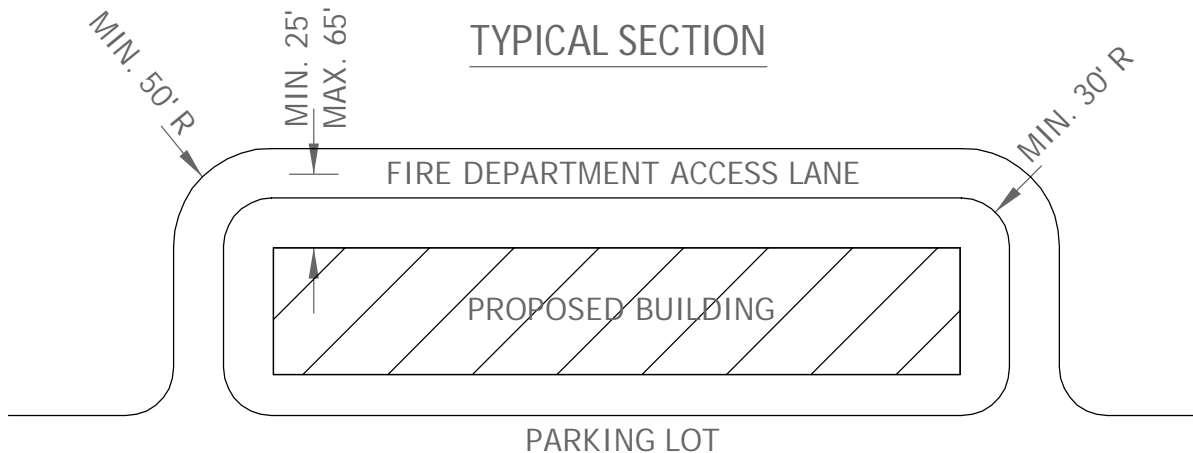

PLAN VIEW

NOTES:

1. DEAD END ACCESS LANES OVER 150' IN LENGTH NEED AN APPROVED TURNAROUND.
2. UNOBSTRUCTED VERTICAL CLEARANCE OF 13'-6" REQUIRED ABOVE ACCESS LANE.
3. PROVIDE FIRE DEPARTMENT APPROVED SIGNS WITHIN 20' OF EVERY ENTRANCE POINT.



STANDARD DETAILS  
 FIRE DEPARTMENT ACCESS LANE  
 BUILDINGS OVER 24' HIGH

**FRIDLEY, MINNESOTA**

LAST REVISION:  
 DEC 2018

CITY PLATE NO.  
 STR-28

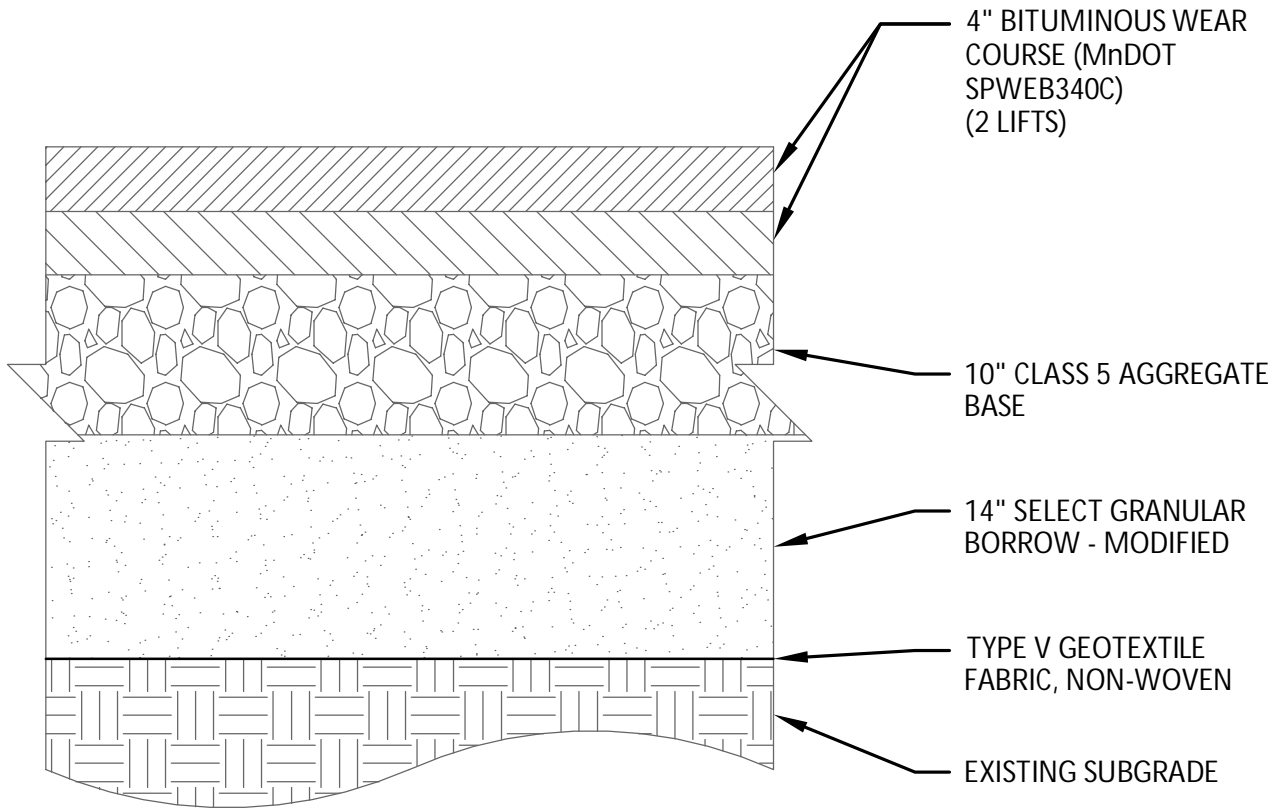

**NOTES:**

1. ALL ORGANIC OR OTHER UNSUITABLE MATERIAL SHALL BE REMOVED FROM BENEATH THE ROADWAY.
2. A TEST ROLL OF THE PREPARED SUBGRADE SHALL BE PERFORMED IN THE PRESENCE OF A CITY INSPECTOR. THE CITY HAS THE AUTHORITY TO REQUIRE ADDITIONAL SUBGRADE CORRECTION AND GRANULAR BORROW, OR ELIMINATE THE STABILIZATION FABRIC AND GRANULAR BORROW.
3. DRAINTILE IS REQUIRED BEHIND CURB, MINIMUM 50' EACH WAY FROM CATCH BASINS.



**STANDARD DETAILS**  
 TYPICAL PUBLIC PARKING LOT SECTION  
**FRIDLEY, MINNESOTA**

LAST REVISION:  
 DEC 2018

CITY PLATE NO.  
 STR-29



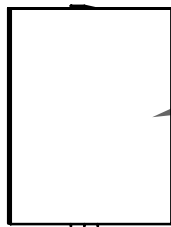

SIGN PANELS AS SPECIFIED OR AS SHOWN ON THE PLANS OR SIGN LEGEND.

1-3/4 INCH TELESPAR SIGN POST

STREET SIGNS

1. BREAK OFF TO BE SET AT FINISH GRADE.
2. ANCHOR SLEEVE TO BE SET WITH TWO BOLT HOLES EXPOSED AND ACCESSIBLE ABOVE FINISH GRADE.

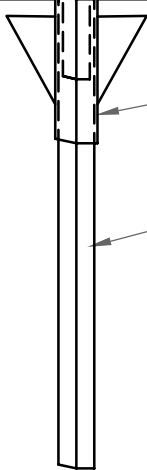

OPTIONAL  
2-1/4 INCH, 18 INCH LONG OMNI SLEEVE

TELESPAR ANCHOR ASSEMBLY  
2 INCH SQUARE, 3 FEET LONG, 12 GA



STANDARD DETAILS  
TYPICAL TRAFFIC SIGN INSTALLATION  
BOULEVARD

FRIDLEY, MINNESOTA

LAST REVISION:  
DEC 2018

CITY PLATE NO.  
STR-30



**DROP LID**  
 TYLER  
 MUELLER  
 BIBBY-STE-CROIX

NO. 6860  
 NO. H-10361  
 NO. B-5160

**NOTES:**

1. VALVE BOX SHALL BE 3-PIECE DUCTILE IRON SCREW-TYPE.
2. 8' MINIMUM COVER REQUIRED OVER TOP OF WATER MAIN.

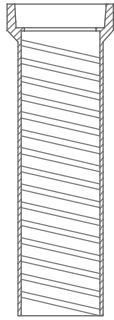

**TOP**  
 TYLER  
 MUELLER  
 BIBBY-STE-CROIX

NO. 6860 26"  
 NO. H-10361 26"  
 NO. VB502 27"

GRADE

ADJUST TOP TO 1/2" BELOW GRADE. BOX TO BE SET TO PROVIDE 12" OF ADJUSTMENT.

**NOTE:**  
 TYLER NO. H-10357  
 BIBBY-STE-CROIX B-5001  
 GATE VALVE BOX, SCREW  
 TYPE, 3 PIECE, 5 1/4"  
 SHAFT, SIZE #6 ROUND  
 BASE.

**EXTENSION**  
 TYLER

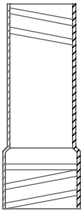

MUELLER  
 BIBBY-STE-CROIX  
 VB520  
 VB521  
 VB522  
 VB523

NO. 58 14"  
 NO. 59 18"  
 NO. 60 24"  
 NO. 58 14"  
 NO. 59 20"  
 NO. 57 9"  
 NO. 58 14"  
 NO. 59 20"  
 NO. 60 26"

EXTENSION ROD-TOP  
 WITHIN 12-18" OF  
 GRADE.

1/4" STEEL GATE VALVE  
 ADAPTOR W/ PROTECTIVE  
 COATING MANUFACTURED BY  
 ADAPTOR, INC. OR EQUAL.

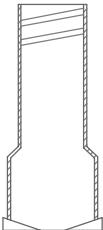

**BOTTOM**  
 TYLER  
 MUELLER  
 BIBBY-STE-CROIX

NO. 6860 65"  
 NO. H-10361 65"  
 NO. VB516 60"

RESILIENT WEDGE  
 VALVE CONFORMING TO  
 AWWA C-509-80  
 STANDARDS.

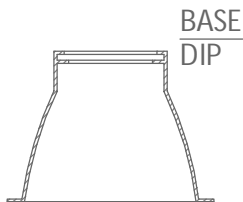

**BASE  
 DIP**

1 1/2" WASHED ROCK  
 ALL AROUND. MIN. 1 CY.

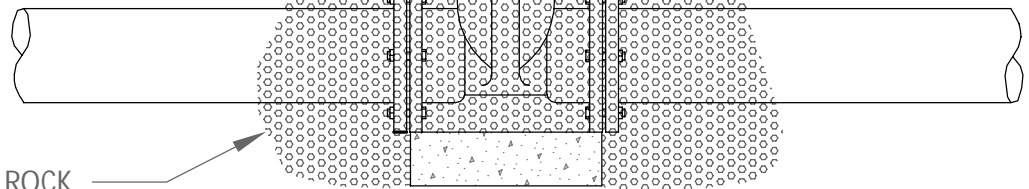

8" CONC. BLOCK



**STANDARD DETAILS**

GATE VALVE AND BOX

**FRIDLEY, MINNESOTA**

LAST REVISION:  
 DEC 2018

CITY PLATE NO.  
 WAT-1

**NOTES:**

1. SHAPE OF BACK OF BUTTRESS MAY VARY AS LONG AS POURED AGAINST FIRM UNDISTURBED EARTH.
2. DIMENSION C1,C2,C3 SHOULD BE LARGE ENOUGH TO MAKE ANGLE  $\theta$  EQUAL TO OR LARGER THAN 45°.
3. DIMENSION A1,A2,A3 SHOULD BE AS LARGE AS POSSIBLE WITHOUT INTERFERING WITH MJ BOLTS.
4.  $\theta$  = 45° MINIMUM.
5. PLACE POLYETHYLENE BETWEEN CONCRETE & PIPE.

**BUTTRESS DIMENSIONS**

PIPE SIZE	22 1/2° BEND		45° BEND		90° BEND	
	B <sub>1</sub>	D <sub>1</sub>	B <sub>2</sub>	D <sub>2</sub>	B <sub>3</sub>	D <sub>3</sub>
6"	1'-5"	1'-5"	1'-5"	1'-5"	2'-1"	1'-6"
8"	1'-5"	1'-5"	2'-1"	1'-6"	2'-8"	2'-0"
12"	1'-10"	1'-10"	3'-4"	2'-0"	4'-9"	2'-6"
16"	3'-0"	2'-0"	3'-10"	3'-0"	6'-2"	3'-6"
20"	3'-6"	2'-8"	5'-6"	3'-4"	8'-4"	4'-0"
24"	4'-4"	3'-0"	6'-10"	3'-10"	9'-8"	5'-0"
30"	-	-	9'-3"	6'-0"	17'-0"	6'-0"

$\theta$  - SEE NOTE 4

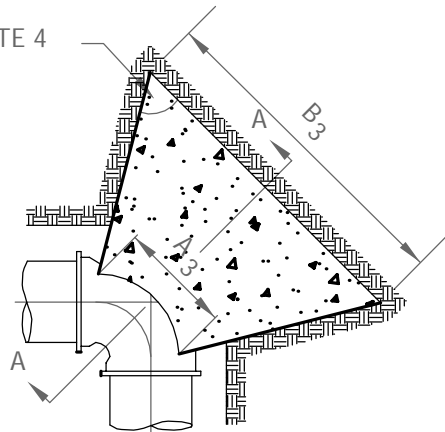

**PLAN 90° BENDS**

$\theta$  - SEE NOTE 4

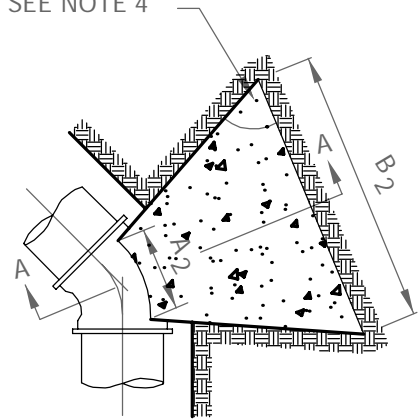

**PLAN 45° BENDS**

CONCRETE SHALL BE IN CONTACT WITH THIS QUADRANT OF PIPE

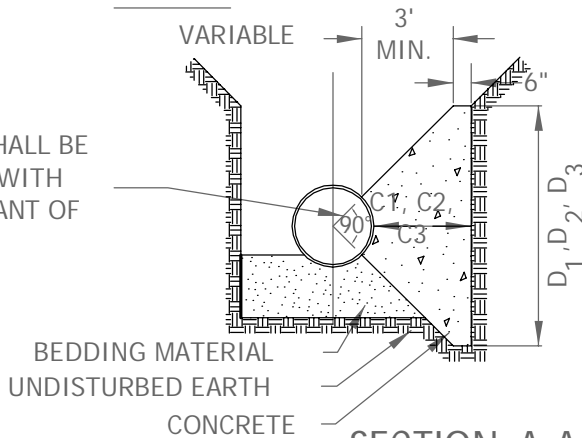

**SECTION A-A**

$\theta$  - SEE NOTE 4

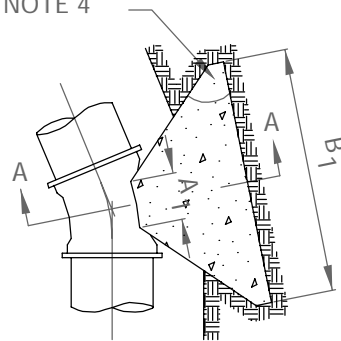

**PLAN 22 1/2° BENDS**



**STANDARD DETAILS**

**CONCRETE THRUST BLOCKING**

**FRIDLEY, MINNESOTA**

LAST REVISION:  
DEC 2018

CITY PLATE NO.  
WAT-6

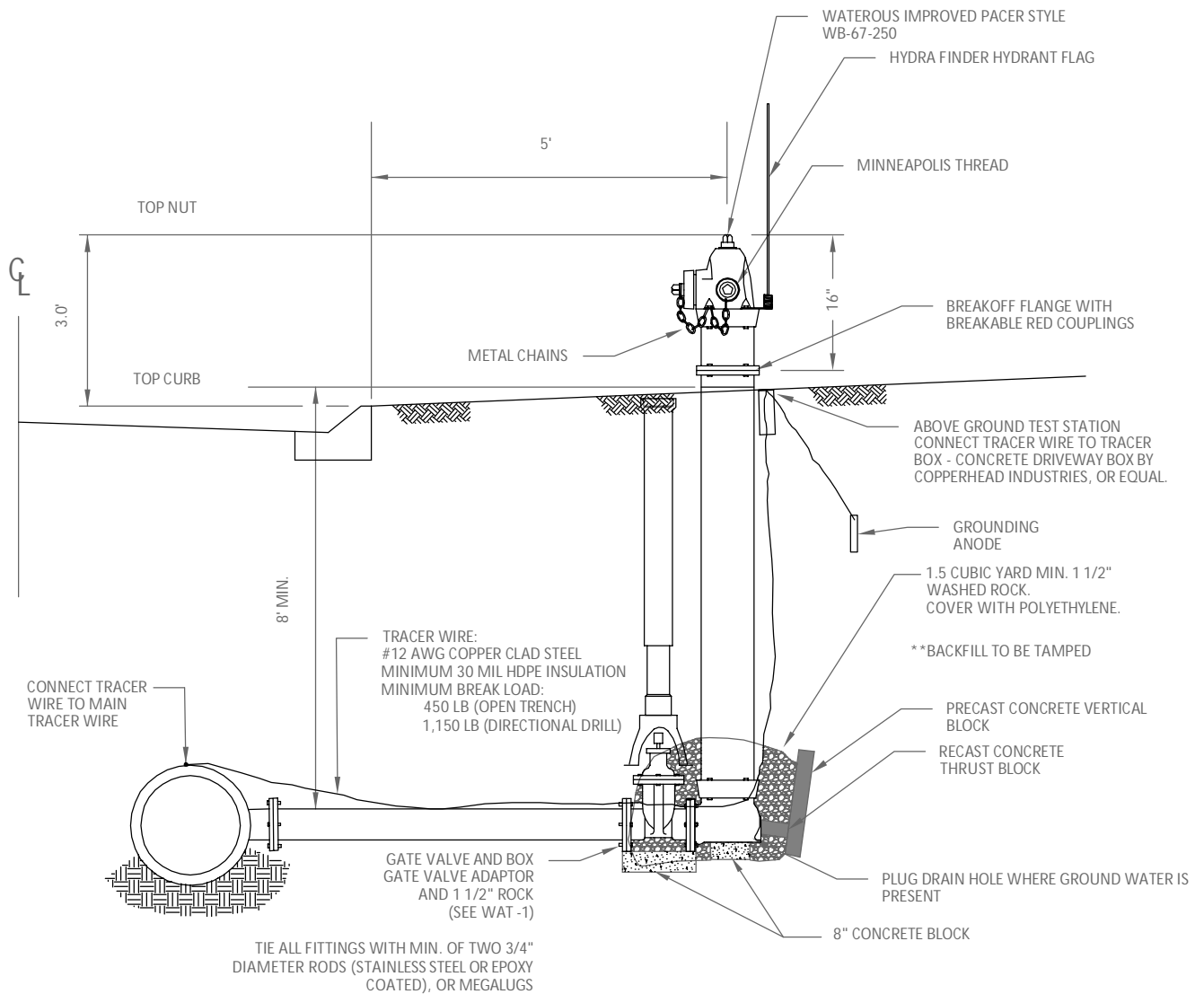

NOTES:

1. HYDRANTS SHALL HAVE ONE 4 1/2 INCH PUMPER NOZZLE AND TWO 2 1/2 INCH SIDE NOZZLES.
2. HYDRANTS SHALL NOT BE MORE THAN ONE YEAR OLDER THAN YEAR OF INSTALLATION
3. FACTORY INSTALLED PLUGS REQUIRED WHENEVER HYDRANTS ARE INSTALLED IN AREAS WITH HIGH GROUNDWATER LEVEL, AS DETERMINED BY DEWATERING REQUIREMENTS AND THE ENGINEER.
4. ALL DUCTILE IRON WATERMAIN FITTINGS FUSION BONDED EPOXY COATED.
5. HYDRANTS SHALL BE MARKED WITH STAINLESS STEEL TAG FROM FACTORY
6. CONTRACTOR SHALL SUPPLY ONE HYDRANT FLAG
7. ALL HYDRANT LEADS ARE TO BE CONSTRUCTED WITH POLY-WRAPPED DIP, CLASS 52
8. PROVIDE POLYWRAP UP THE HYDRANT BARREL TO THE BREAK OFF FLANGE
9. ALL WATERMAIN BOLTS SHALL BE COR-BLUE OR APPROVED EQUAL
10. HYDRANTS SHALL BE PAINTED IN ACCORDANCE WITH THE FOLLOWING SCHEDULE: FLOW RATE OF 1,000 GPM OR MORE - GREEN; FLOW RATE BETWEEN 500 GPM AND 1,000 GPM - YELLOW; FLOW RATE OF 500 GPM OR LESS - RED
11. ABOVE GROUND TEST STATION SHALL BE COBRA T3 (T2-R75) OR APPROVED EQUAL. OUTDOOR RATED PVC CONDUIT SHALL BE INSTALLED FROM BOTTOM OF TEST STATION TO 2' BELOW FINISHED GRADE
12. MIN 1 LB. DRIVE IN ANODE WITH MIN 20' WIRE LEAD.
13. CONNECTORS SHALL BE DRY CONN DIRECT BURY LUG AQUA, PRO-TRACE DB OR APPROVED EQUAL



STANDARD DETAILS

HYDRANT

FRIDLEY, MINNESOTA

LAST REVISION:  
DEC 2018

CITY PLATE NO.  
WAT-8

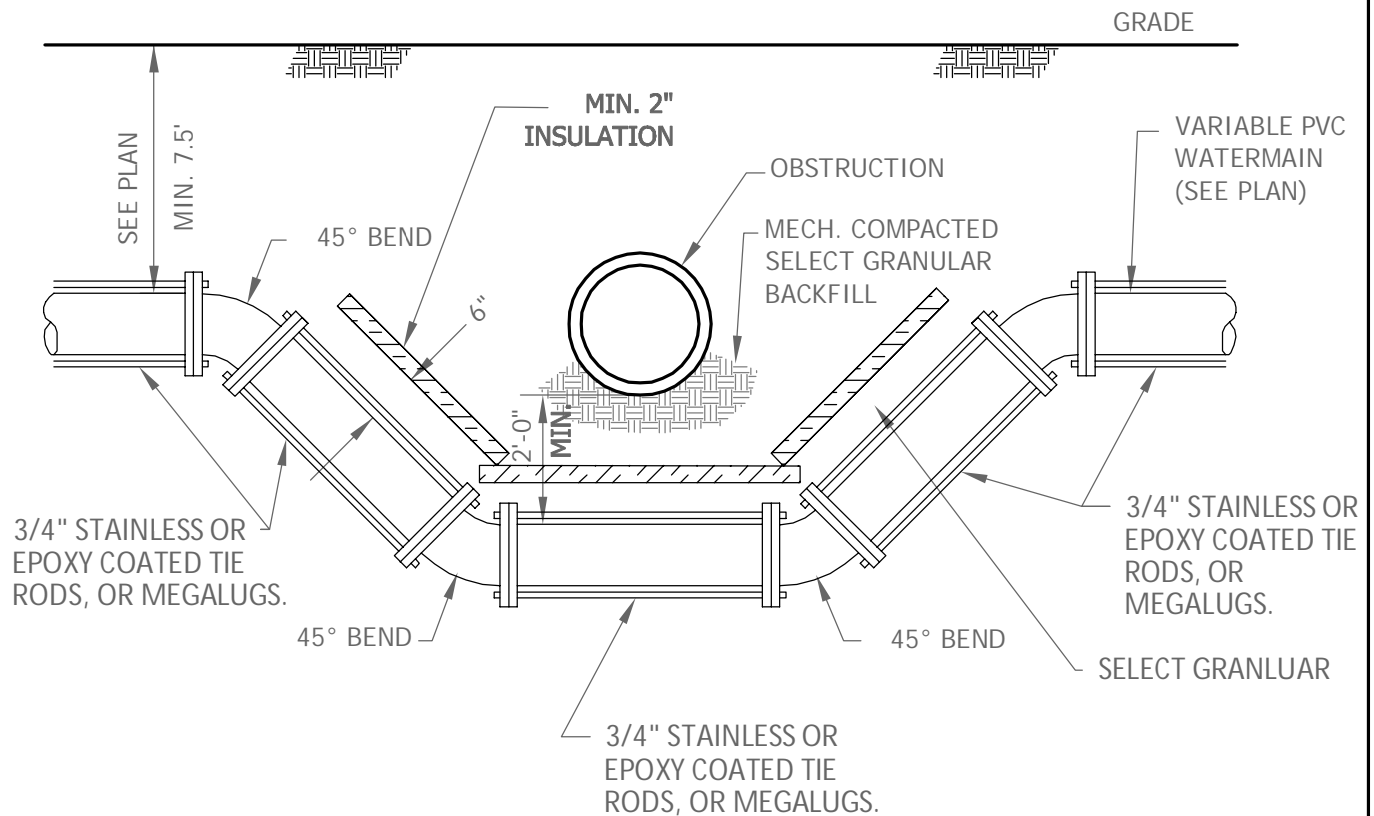

NOTE:

1. ALL FITTINGS SHALL BE FUSION BONDED EPOXY COATED DUCTILE IRON TO MEET OR EXCEED ANSI/AWWA C550 AND C116/A21.16 REQUIREMENTS.
2. MEGALUGS WILL NOT BE ALLOWED ON ANY CIP WATER MAIN.
3. SELECT GRANULAR WILL BE REQUIRED BETWEEN INSULATION, WATER MAIN, AND OBSTRUCTION.
4. ALL BENDS SHALL HAVE MEGALUGS OR TIE RODS WITH BLOCKING IN ACCORDANCE WITH STANDARD PLATE WAT-03.
5. COPPER TRACER WIRER SHALL BE USED ON PVC WATER MAIN.
6. ALL WATER MAIN BOLTS SHALL BE CORE-BLUE OR APPROVED EQUAL.



STANDARD DETAILS

WATER MAIN OFFSET

FRIDLEY, MINNESOTA

LAST REVISION:  
DEC 2018

CITY PLATE NO.  
WAT-10

ONE MAIN METER  
 BILLING GOES TO MANAGEMENT  
 COMPANY INDIVIDUAL METERS  
 MAY BE ADDED FOR EACH UNIT  
 FOR MANAGEMENT BILLING  
 BREAK DOWN.

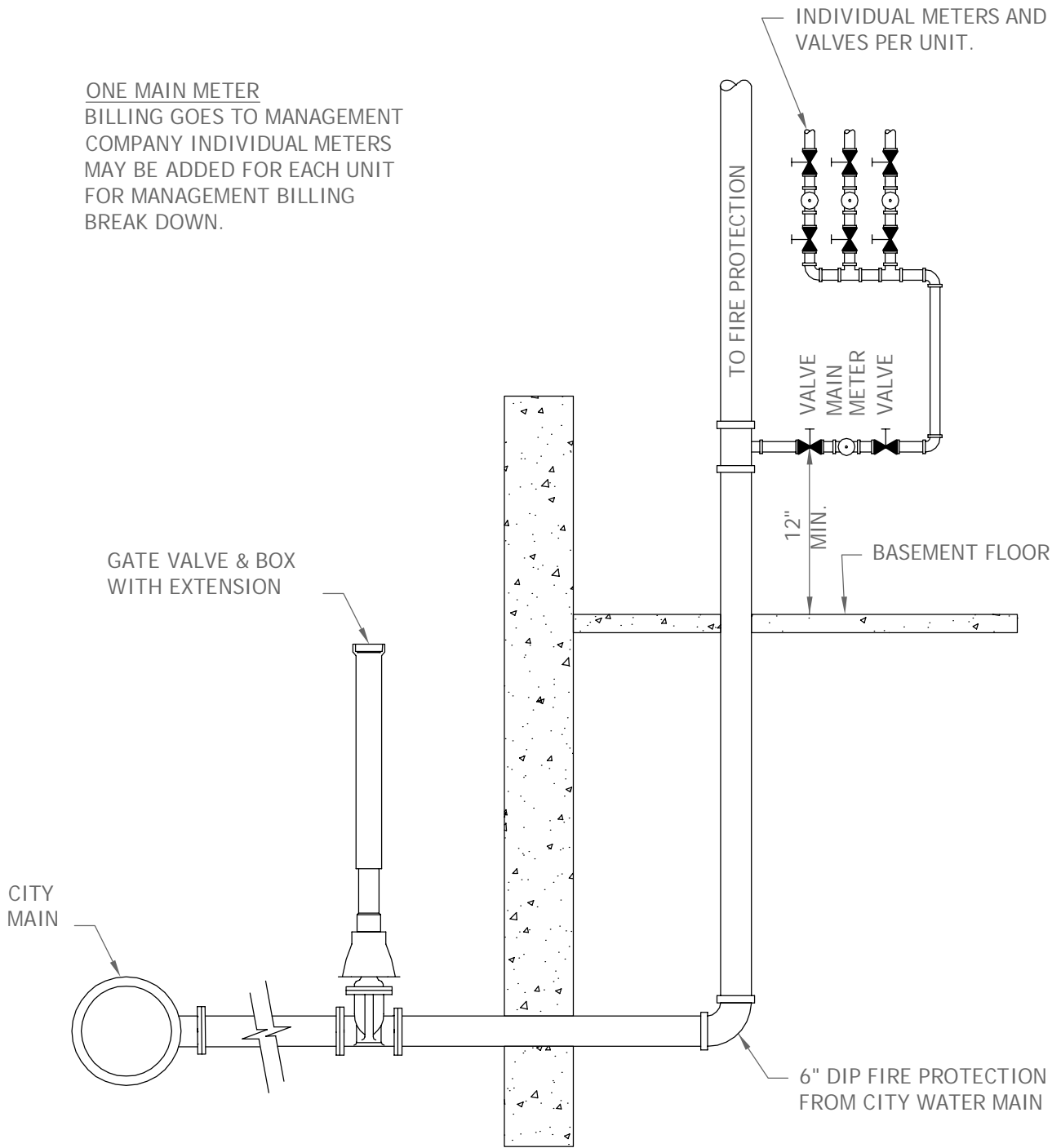

NOTE: ALL METERS MUST BE LOCATED IN A  
 CENTRAL ROOM AT POINT WHERE  
 WATER SERVICE ENTERS BUILDING.  
 IRRIGATION LINES MUST ALSO HAVE  
 SEPARATE METER IF LINE IS  
 CONNECTED PRIOR TO MAIN.



**STANDARD DETAILS**  
 MULTIPLE UNITS  
 USING MAIN WATER METER

**FRIDLEY, MINNESOTA**

LAST REVISION:  
 DEC 2018

CITY PLATE NO.  
 WAT-11

INDIVIDUAL METERS  
PER UNIT AND EACH UNIT IS  
BILLED SEPARATELY.

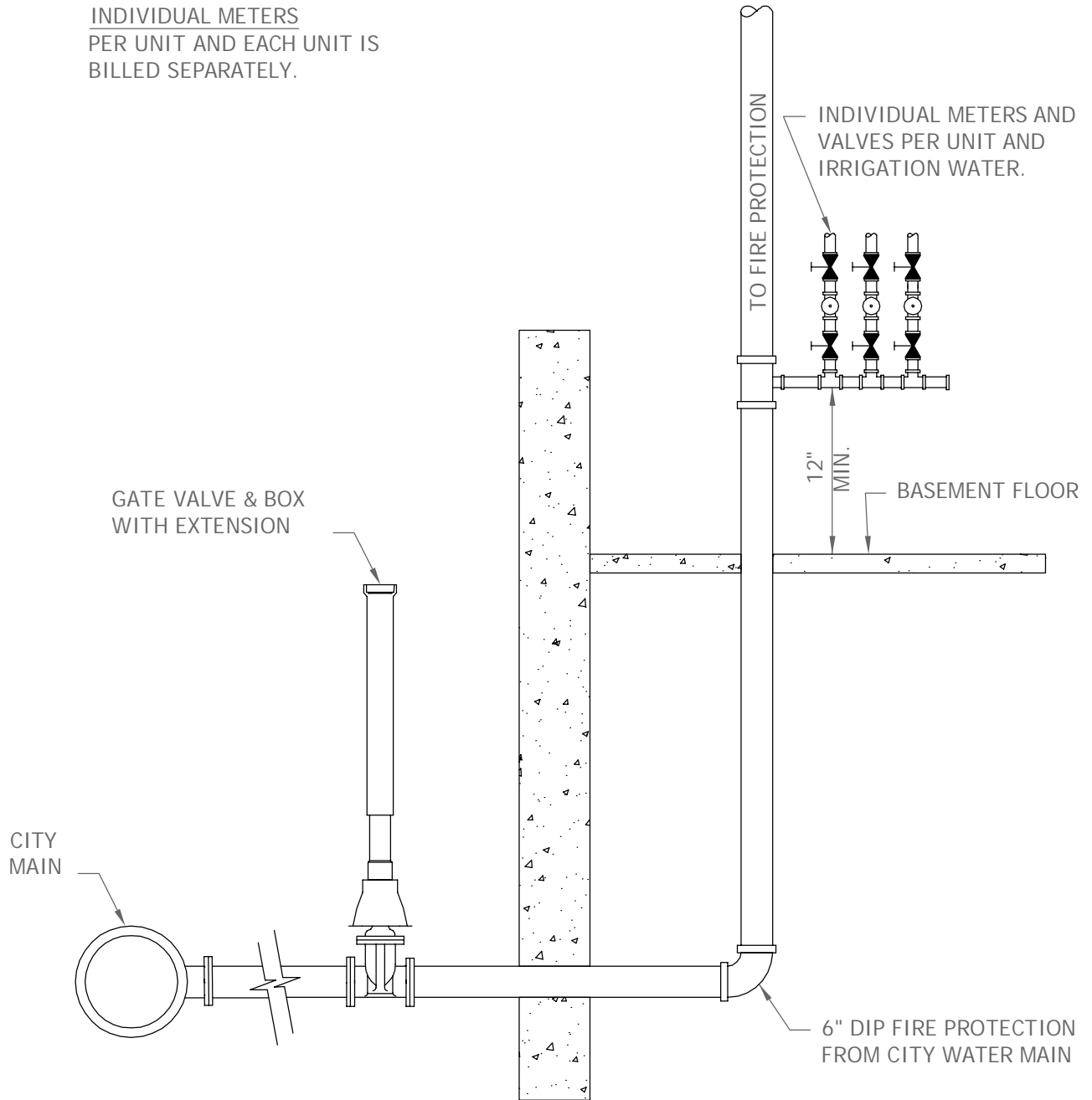

NOTE: ALL METERS MUST BE LOCATED IN A CENTRAL ROOM AT POINT WHERE WATER SERVICE ENTERS BUILDING. IRRIGATION LINES MUST ALSO HAVE SEPARATE METER IF LINE IS CONNECTED PRIOR TO MAIN.



STANDARD DETAILS  
MULTIPLE UNITS  
INDIVIDUAL WATER METER

FRIDLEY, MINNESOTA

LAST REVISION:  
DEC 2018

CITY PLATE NO.  
WAT-12