

GARAGE SLABS

1000 SQ FT AND UNDER



Building Inspections Department
7071 University Ave N.E., Fridley, MN 55432
Phone: 763-572-3604 | Email: BuildingInspections@fridleymn.gov
www.fridleymn.gov

This handout is intended only as a guide and is based in part on the 2020 Minnesota Residential Code, Fridley City ordinances, and good building practice. While every attempt has been made to insure the correctness of this handout, no guarantees are made to its accuracy or completeness. Responsibility for compliance with applicable codes and ordinances falls on the owner or contractor. For specific questions regarding code requirements, refer to the applicable codes or contact your local Building Department.

DRAINAGE

The area around any building must be sloped a minimum of 6 inches in the first ten feet for drainage.

CONCRETE STRENGTH

Minimum compressive strength for garage and carport slabs is 3,500 psi and for basement floors and other interior slabs 2,500 psi.

The State made a major change in the code relative to footings. ***All footings must have a minimum compressive strength of 5000 psi or contain an approved admixture that provides a water and vapor resistance at least equivalent to 5000 psi concrete. How does this apply to slabs?***

- Basement floor slabs with integral footings must provide for 5000 psi concrete in that portion of the slab acting as a footing.
- Slabs for detached garages 1000 square feet or under with a thickened edge acting as the footing must provide for 5000 psi concrete in that portion of the slab acting as the footing.

When ordering ready-mix concrete, it is best to explain the type of project to the ready-mix producer and specify the strength you desire or what is required by code and they will provide a mix to meet your needs.

AIR ENTRAINED CONCRETE

Air entrained concrete is required by the code whenever the concrete will or may be exposed to freezing temperatures. Concrete used for garage and carport slabs must be air-entrained between 5-7%.

REINFORCEMENT

Properly positioned reinforcement is used to reduce crack widths and minimize horizontal separation and is **recommended** in concrete slabs.

Rebar should be minimum Grade 40 reinforcing steel. Welded wire fabric should be minimum WWF 6x6-10/10. Reinforcing steel should be properly tied with wire to rigidly support it in its proper position. When reinforcing steel or welded wire fabric is used, it is **required to be supported** in place from the center to the upper one third of the slab for the duration of the concrete placement.

Rebar should always be bent cold. The diameter of the bend should be at least six times the bar diameter. For 1/2" rebar the inside of the bend should have a diameter of at least 3 inches. When overlapping rebar, the length of the overlap should be at least 40 bar diameters. The laps should be tied together with wire.

For garage slabs, two rows of #4 rebar are recommended around the perimeter, one above the other. The bottom row should be 3 inches minimum from the bottom of the perimeter footing. The top row should be placed approximately 1/3 of the distance from top of the perimeter footing.

REBAR SUPPORTS



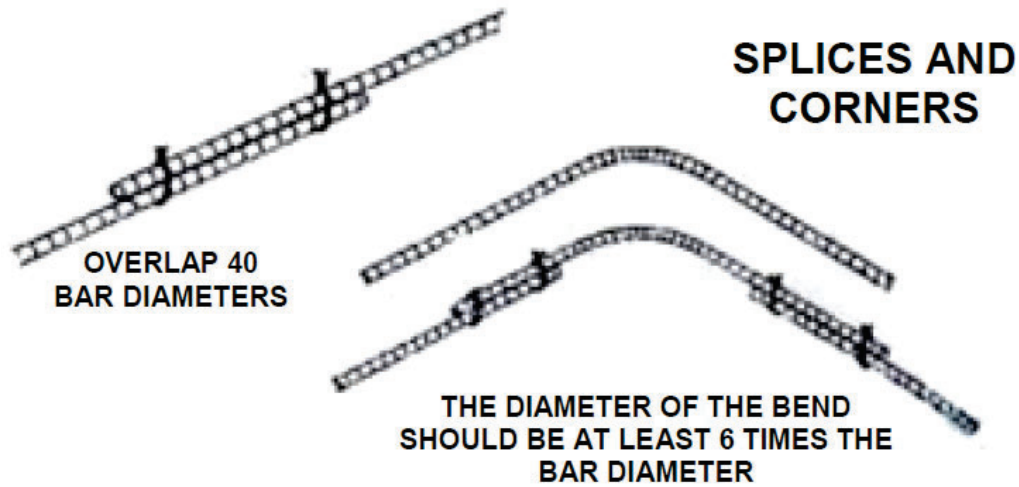

CONCRETE GARAGE FLOOR SLAB-ON-GRADE FOUNDATION

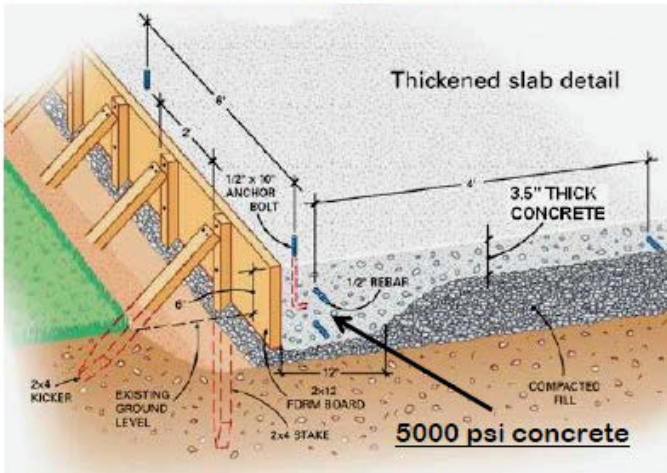

CONCRETE BASEMENT FLOOR

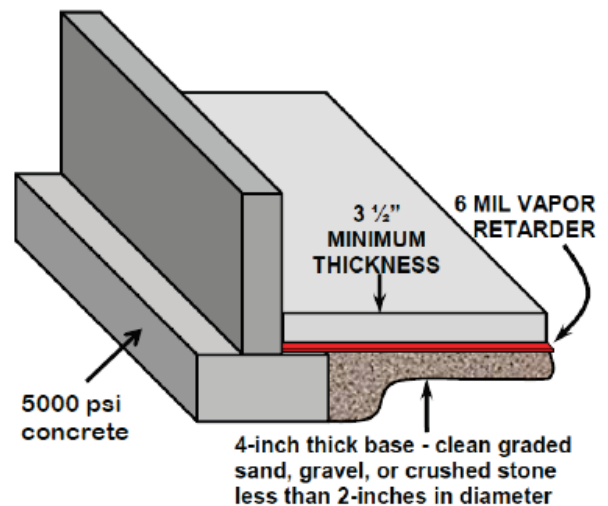

FOUNDATION ANCHORAGE

The wood sole plate for all exterior walls on monolithic slabs must be anchored with bolts spaced a maximum of 6 feet apart and within 12 inches of each end. Bolts must be at least 1/2" diameter and extend at least 7 inches into the slab. Plates must be tightened to the bolt with a nut and washer. Where anchor straps are used, they must be designed and installed in a manner equivalent to anchor bolts. (R403.1.6).

WOOD AND STEEL COLUMNS AND CONCRETE

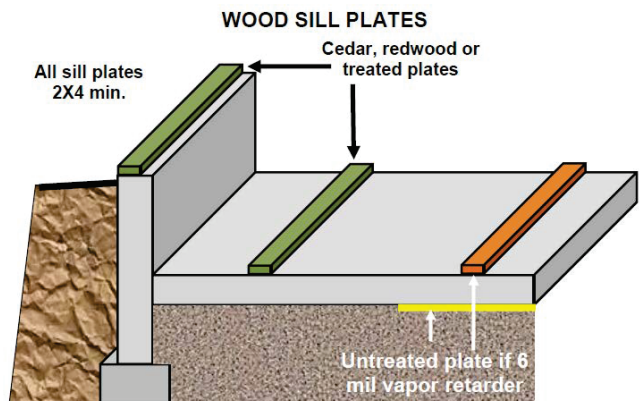
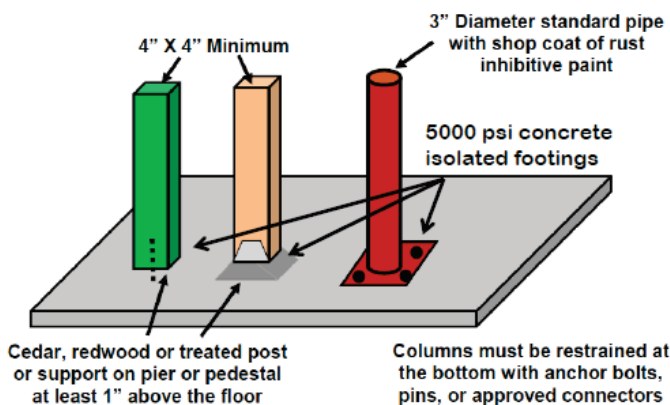

ISOLATION OR CONTRACTION JOINTS

Isolation or contraction joints are grooved, formed, or sawed into sidewalks, driveways, pavements, floors, and walls so that cracking will occur in these joints rather than in a random manner.

Maximum Recommended Spacing of Contraction Joints in Feet			
Slab thickness, inches	Slump 4 inches to 6 inches		Slump less than 4-inches
	Maximum-size when is aggregate less than $\frac{3}{4}$ inch	Maximum-size when is aggregate $\frac{3}{4}$ inch and larger	
4	8	10	12
5	10	13	15
6	12	15	18

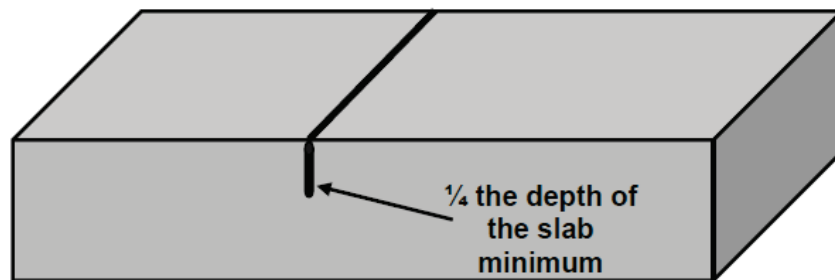

HOT AND COLD WEATHER ISSUES

Hot Weather

Hot weather can result in accelerated setting of the concrete that will reduce workability and finishing time. To avoid this problem, pouring of concrete should be planned to avoid warm days if possible. Proper curing methods are also more important during warmer weather than when temperatures are more moderate.

Cold Weather

Concrete can safely be poured in temperatures above freezing. Any snow or ice must be removed before concrete is poured and concrete should never be poured on frozen ground. Once poured, concrete should be protected from freezing for at least two to three days after it is poured by the use of insulating blankets, enclosures, or other means. Concrete that is frozen before proper curing will suffer strength reductions and will not be as resistant to weathering or watertight as concrete that has not been frozen. Use of air-entrained concrete is more important for concrete that has the potential to be frozen, as it will improve the strength characteristics of the concrete.