

# BASEMENT FINISHING



Building Inspections Department  
7071 University Ave N.E., Fridley, MN 55432  
Phone: 763-572-3604 | Email: [BuildingInspections@fridleymn.gov](mailto:BuildingInspections@fridleymn.gov)  
[www.fridleymn.gov](http://www.fridleymn.gov)

This handout is intended only as a guide and is based in part on the 2020 Minnesota Residential Code, Fridley City ordinances, and good building practice. While every attempt has been made to insure the correctness of this handout, no guarantees are made to its accuracy or completeness. Responsibility for compliance with applicable codes and ordinances falls on the owner or contractor. For specific questions regarding code requirements, refer to the applicable codes or contact your local Building Department.

## PERMITS AND PLANS

Building permits are required if you are finishing unfinished space in your basement, changing the use of space such as converting a recreation room to a bedroom, and for some repairs.

Plans are required for any finishing or change of use. Plans should be neat scale drawings that include a floor plan, window sizes and locations, cross sections, and any notes that would help explain the nature and extent of your project. Once submitted, it may take up to ten (10) business days before your permit will be ready so please submit your plans and permit application well in advance of the date when work will begin.

Inspections are required of all work. When your permit is issued, you will receive an inspection record card that will tell you which inspections to call for and the number to call. Inspections are made by appointment. Requests for inspections should be made at least 24 hours in advance.

If you have any questions on the permitting process, contact the Building Department.

### REQUIRED PERMITS

- Building Permit for framing and finish work
- Electrical Permit for receptacles, lights, electric floor heat, etc.
- Mechanical for ductwork, bath fan, heat registers, etc.
- Plumbing Permit for any underground plumbing, fixtures, etc.

## NOW IS THE TIME!!

Prior to finishing any basement space, it is advisable to address any deferred maintenance items prior to the start of work. This would include damp proofing walls, patching any cracks in concrete or masonry walls and concrete floors, and repairing any joists or studs that have been over-bored or cut without being properly supported. If you have considered installing drain tile and a sump pump, now would be the time to do that as well.

## **HOMES WITH RESIDENTIAL FIRE SPRINKLERS**

If you are finishing or altering space in a home that has a fire sprinkler system, you must provide revised sprinkler plans and calculations showing compliance with either NFPA 13D or MRC section P2904. Non-metallic sprinkler pipe may be required to be installed only in concealed locations. If you plan to leave any sprinkler pipe exposed, be prepared to provide the manufacturer's instructions that permit exposure.

### **GENERAL INFORMATION**

- Ceiling heights in basements should be a minimum of 6 feet 4 inches.
- Bathrooms must be provided with ventilation via a window with at least 1.5 square feet of open area or a mechanical exhaust fan with a minimum rating of 50 cfm. Rigid metal duct creates much less resistance to air flow and will improve the efficiency of your bath fan.
- Toilets must be installed in a space at least 30 inches wide and at least 24 inches of clear space must be provided in front of the toilet.
- Showers should have a clear space within the stall of at least 30 inches.
- Fireplaces and stoves may be installed in basements but must be installed in strict accordance with the manufacturers written instructions.
- Rooms, other than storage spaces, must be at least seventy (70) square feet in area, with minimum dimension not less than seven feet (7').
- Nail plates should be installed wherever nails or screws may come in contact with electrical wiring, plumbing, or gas piping.

### **EGRESS WINDOWS**

An egress window is required whenever a bedroom is created or per 310.5 of the 2020 IRC. If an egress window is installed in a basement bedroom, an additional egress window is not required in the balance of the basement unless there are additional bedrooms. See the Emergency Escape and Rescue Opening handout for information on egress windows.

### **GENERAL FRAMING INFORMATION**

Non-bearing wood framed walls may be 2X4 studs at 16 or 24 inches on center. Walls must have a bottom plate and at least a single top plate. Plates in contact with concrete floors must be treated wood, redwood, or cedar unless separated by an impervious moisture barrier. For stud size and spacing for bearing walls, contact the Building Department. Wood used for framing soffits may be 2X2 material.

Headers in non-bearing walls may consist of a 2X4 laid flat for openings up to 8 feet wide. No cripples or blocking are required above the header provided the distance from the header to the floor joist above is not more than 24 inches. For headers in bearing walls, contact the Building Department.

Do not remove any existing partitions unless you have determined that they are not load bearing partitions. If any portion of a load bearing partition is removed, a header or beam must be installed to transfer the load to a footing.

Wood veneer paneling must be placed on wood framing spaced not more than 16 inches on center. Wood veneer paneling less than 1/4 inch nominal thickness must have not less than a 3/8 inch gypsum board backer.

## **DRILLING AND NOTCHING OF FRAMING MEMBERS**

Drilling and notching of open web trusses or laminated veneer lumber (LVL) beams is not permitted without an approved design from the manufacturer or a structural engineer.

Drilling and notching of I-joists is permitted in accordance with the manufacturers written installation instructions. You should obtain a copy of these instructions before starting any work.

The Building Department has a handout on Cutting, Notching and Boring framing members that should be used as a guide for repairs when dimension lumber is used.

## **FIREBLOCKING**

Fireblocking is required in a number of locations throughout a dwelling to impede the spread of smoke, hot gases, and flames through the framework in the event of a fire. The two most common locations where fire blocking is required in a basement are at concealed wall to ceiling intersections and at wire/pipe/duct penetrations. Anytime there is a concealed path from a stud space into the ceiling, that path must be fireblocked. Also, whenever a pipe, wire, or duct penetrates the top of a wall, the space around the penetration must be fireblocked. Fireblocking may consist of 2-inch nominal lumber, two thicknesses of 1-inch nominal lumber,  $\frac{3}{4}$  -inch plywood or particleboard with joints backed with  $\frac{3}{4}$  -inch plywood or particleboard,  $\frac{1}{2}$  -inch gypsum board, or batts or blankets of mineral wool or glass fiber insulation. Fireblocking should be installed and inspected as part of the framing or insulation inspection.

There are also a number of approved caulks on the market that are approved for fireblocking small areas. You may find these easier and quicker to use than the more generic methods. These materials are available a local building supply stores. Be sure the caulk that you buy is labeled as non-combustible.

## **INSULATION**

The method and type of insulation you use is entirely up to you. If you use foam plastic insulation, it must be covered with  $\frac{1}{2}$  -inch gypsum board unless the foam plastic is approved for use without the covering.

## **CARBON MONOXIDE AND SMOKE ALARMS**

Carbon monoxide alarms must be installed outside and not more than ten feet from each sleeping room **on each floor**. Smoke alarms must be located **in** each bedroom **and on each floor** of the dwelling including the basement. Alarms must be installed in accordance with the manufacturers written instructions. Where framing is exposed, alarms must be hard wired with a battery backup and must be interconnected with other hardwired alarms. When framing is not exposed or it is not feasible to hardwire a smoke alarm, battery powered detectors may be used.

## **COMBUSTION AIR FOR FURNACES AND WATER HEATERS**

If you are enclosing the space housing your furnace and/or water heater, you may need to provide additional combustion air by installing an exterior combustion air duct or providing openings in the enclosing walls or doors. If you have any questions regarding the issue of combustion air, please contact the Building Department.

## **ELECTRICAL, PLUMBING, AND HEATING INSTALLATIONS**

All electrical, plumbing and mechanical work is subject to inspections. Separate permits are required for each. Make sure to apply for these permits prior to starting work.

Plan examples

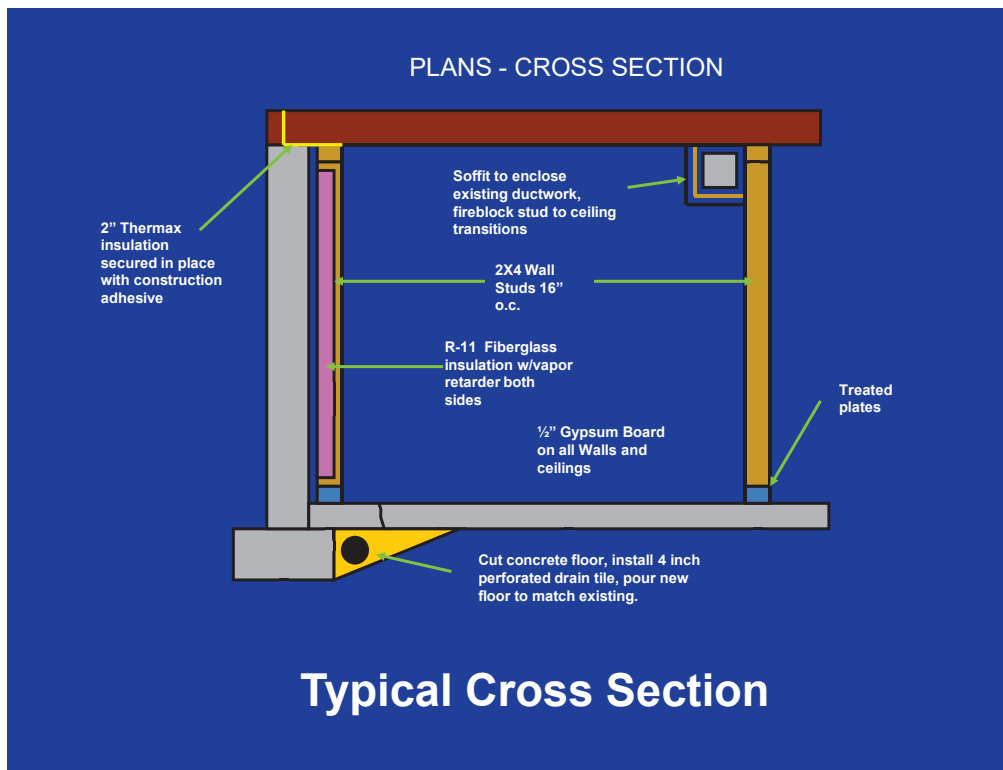
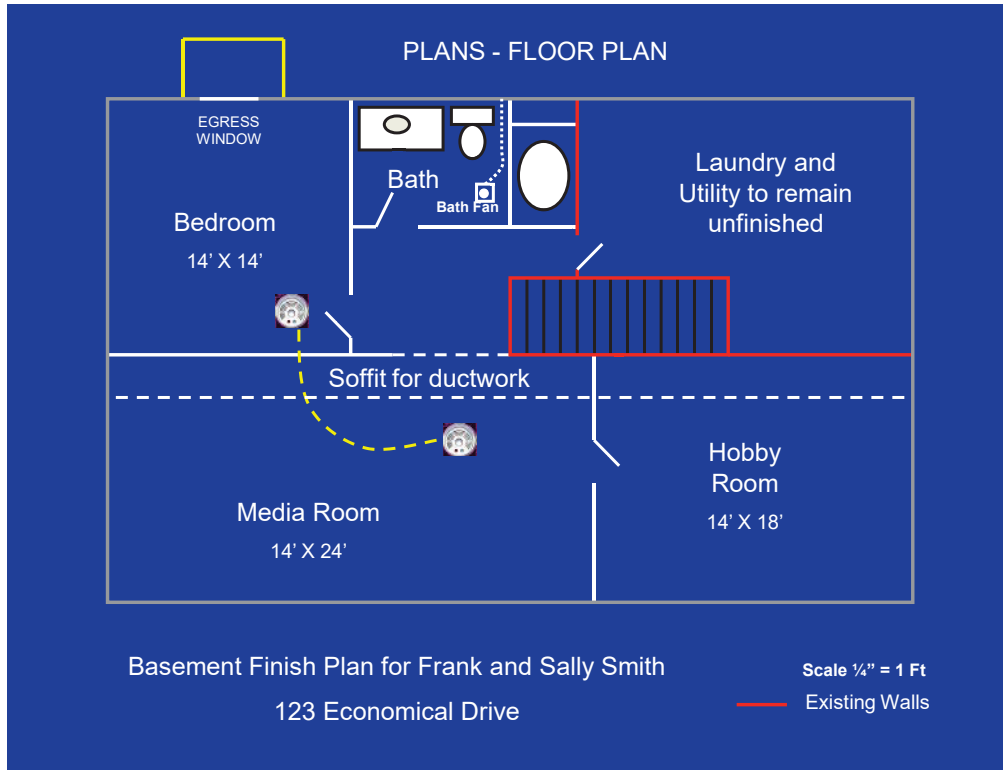

# EGRESS/ESCAPE WINDOWS AND WINDOW WELLS



Building Inspections Department  
7071 University Ave N.E., Fridley, MN 55432  
Phone: 763-572-3604 | Email: BuildingInspections@fridleymn.gov  
www.fridleymn.gov

This handout is intended only as a guide and is based in part on the 2020 Minnesota Residential Code, Fridley City ordinances, and good building practice. While every attempt has been made to insure the correctness of this handout, no guarantees are made to its accuracy or completeness. Responsibility for compliance with applicable codes and ordinances falls on the owner or contractor. For specific questions regarding code requirements, refer to the applicable codes or contact your local Building Department.

## SCOPE

If you are planning on adding a bedroom, **a permit is required for this work**. You **must have a second means of egress** in either a window or a door. This egress must be on an exterior wall. If a window is provided, it must meet certain standards as follows:

1. Must be 5.7 square feet of net clear opening.
  - Grade floor openings shall have a minimum net clear opening of 5.0 square feet. Grade floor opening is a window or other opening located such that the sill height of the opening is not more than 44 inches above or below the finished ground level adjacent to the opening.
2. Glass minimum of twenty inches (20") in width of clear opening.
3. Glass minimum of twenty-four inches (24") in height of clear opening.
4. Cannot be over forty-four inches (44") from the finished floor to the top of the sill.

The window well (exterior) must be thirty-six inches (36") wide and go out thirty-six inches (36") from the foundation.

A smoke alarm must be installed outside the bedroom door and another smoke alarm must be installed in the bedroom. A Carbon Monoxide Alarm must be installed within 10 feet of every bedroom. (See Smoke Alarms/Carbon Monoxide Alarm Handout for more information.)

If you are considering remodeling your basement or lower level to make it more energy efficient and if you use any kind of Styrofoam insulation, it must be covered with ½ inch drywall (sheetrock). When Styrofoam burns, it creates very hazardous, toxic fumes. All wood plates that come in contact with concrete must be treated. (See Basement Finish handout for more information.)

If further information is needed, please contact the Building Inspection Department 763-572-3604.

## ESCAPE AND RESCUE WINDOWS

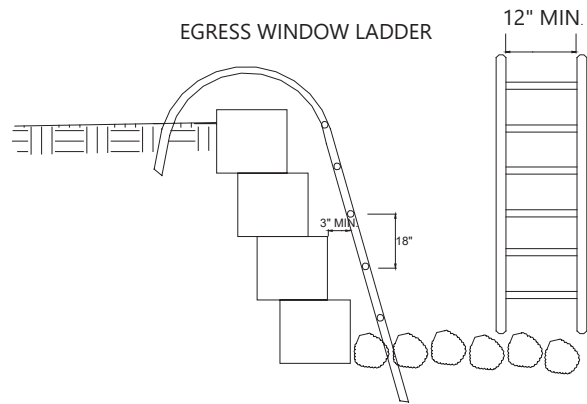
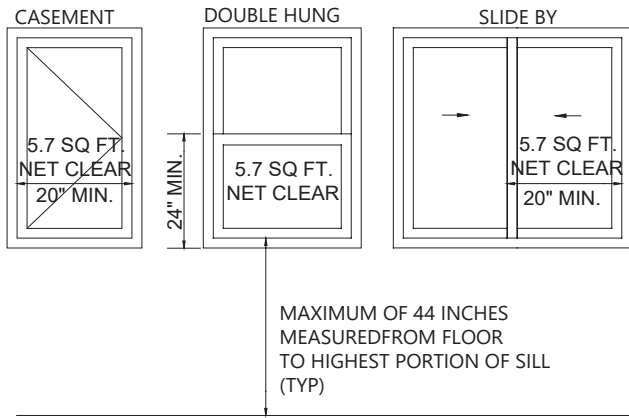

LADDERS OR RUNGS SHALL HAVE AN INSIDE WIDTH OF AT LEAST 12 INCHES, SHALL PROJECT AT LEAST 3 INCHES FROM THE WALL AND SHALL BE SPACED NOT MORE THAN 18 INCHES ON CENTER VERTICALLY FOR THE FULL HEIGHT OF THE WINDOW WELL.

## ACCESS AND EXIT FACILITIES AND EMERGENCY ESCAPES

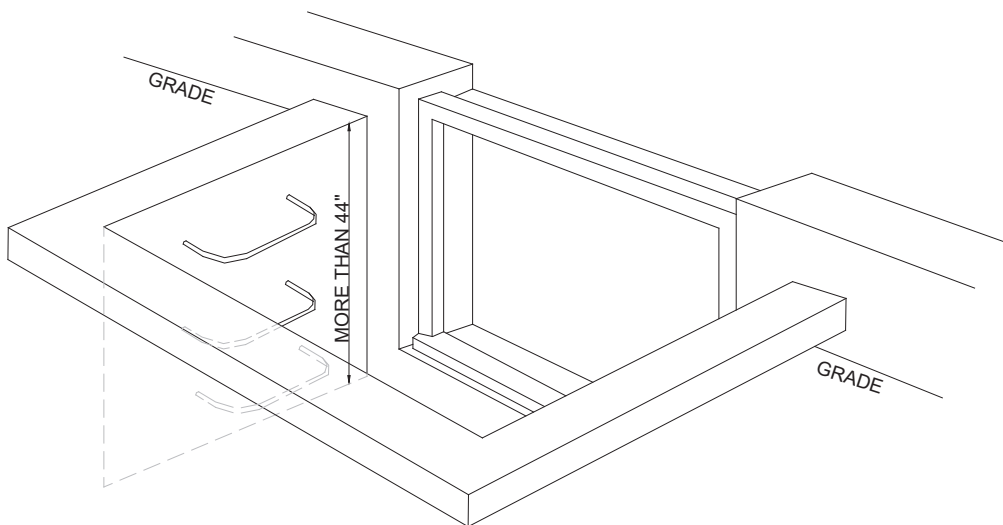

WINDOW WELLS WITH A VERTICAL DEPTH OF MORE THAN 44 INCHES SHALL BE EQUIPPED WITH AN APPROVED PERMANENTLY AFFIXED LADDER OR STAIRS THAT ARE ACCESSIBLE WITH THE WINDOW IN THE FULLY OPEN POSITION. THE LADDER OR STAIRS SHALL NOT ENCROACH INTO THE REQUIRE DIMENSIONS OF THE WINDOW WELL BY MORE THAN 6 INCHES.

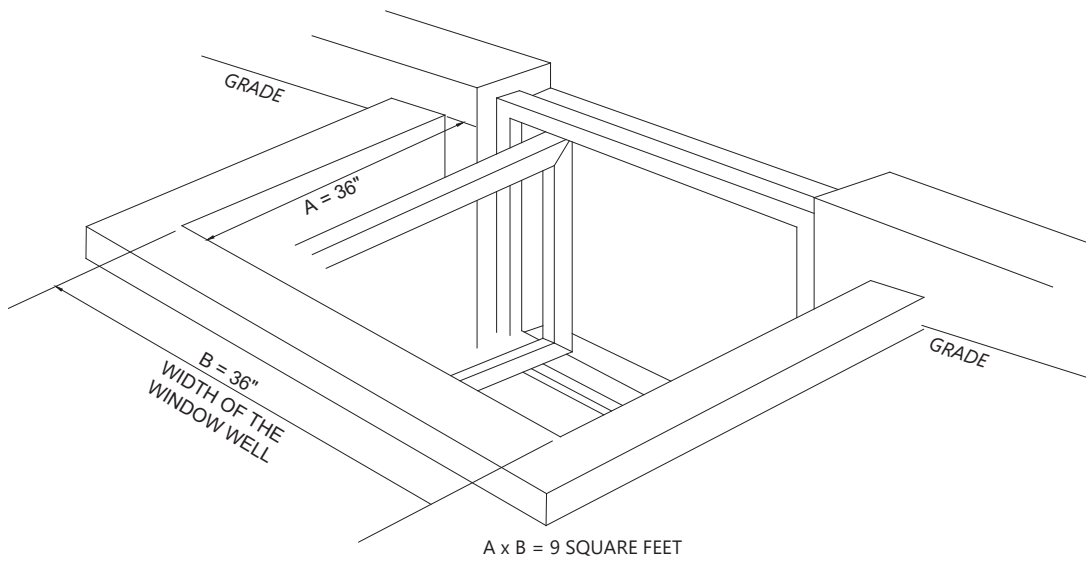

THE CLEAR HORIZONTAL DIMENSIONS SHALL ALLOW THE WINDOW TO BE FULLY OPENED AND PROVIDE A MINIMUM ACCESSIBLE NET CLEAR OPENING OF 9 SQUARE FEET, WITH A MINIMUM DIMENSION OF 36 INCHES.

### EMERGENCY ESCAPE AND RESCUE WINDOWS

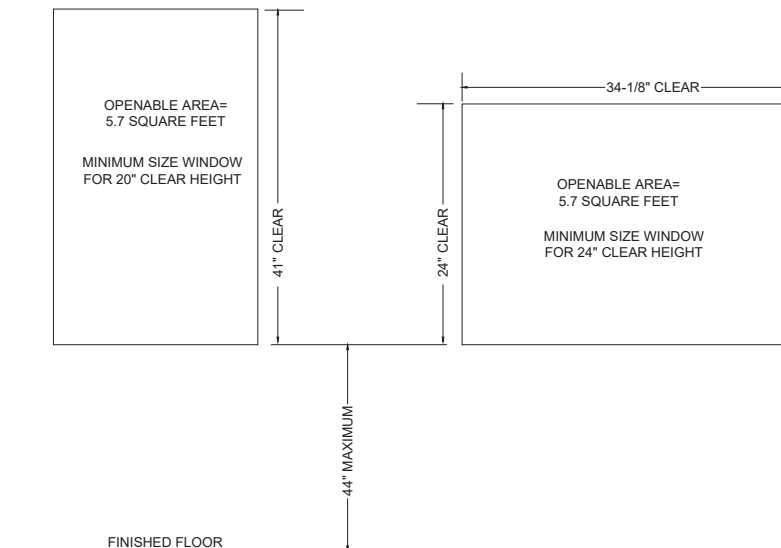

Because so many fire-related casualties occur when occupants of residential buildings are asleep at the time of a fire, Section 310.1 of the 2020 Minnesota Residential Code (MNRC) that:

1. Basements of dwelling units; and
2. Every bedroom below the fourth story shall have at least one (1) operable window or door approved for emergency escape and rescue. This exit shall open directly into a public street, public alley, yard, or exit court. The units shall be operable to provide a full clear opening without the use of separate tools.

Extensive testing by the San Diego Building and Fire Departments established the minimum window size requirements found in Section 310.1.1:

1. The new Clear Opening area shall be no less than 5.7 square feet (0.53 m<sup>2</sup>).
2. In addition to the above requirement, the net clear openable height dimension shall be a minimum of 24 inches (610 mm). The net clear openable width dimension shall be a minimum of 20 inches (508 mm). Note that using both minimum figures will not obtain the required area.
3. The finished sill height shall be not more than 44 inches (1118 mm) above the floor.

**Minimum Width/Height Requirements for Emergency Escape and Rescue Windows (inches\*)**  
(1inch=25.4 mm)

Width	20	20.5	21	21.5	22	22.5	23	23.5	24	24.5	25	25.5	26	26.5	27
Height	41	40	39.1	38.2	37.3	36.5	35.7	34.9	34.2	33.5	32.8	32.2	31.6	31	30.4
Width	27.5	28	28.5	29	29.5	30	30.5	31	31.5	32	32.5	33	33.5	34	34.2
Height	29.8	29.3	28.8	28.3	27.8	27.4	26.9	26.5	26.1	25.7	25.3	24.9	24.5	24.1	24