



# Aerial Fire Apparatus Replacement

---

Resolution No. 2023-42



# Existing Apparatus

- 2006 Crimson Gladiator Aerial, 110' Platform
- 20,691 miles
- 2022 Statistics
  - 600 Miles
  - 55 Calls (46 Fires)
  - 60 Days Out of Service
  - \$18,000 Annual Maintenance



# Background

- Low bid accepted.
- New model (SN#4), other three have since been decommissioned.
- Over \$600,000 in documented warranty and maintenance work.
- Truck has shown critical failures while operating on emergency scenes and training scenarios resulting in lower confidence by firefighters.

# Action

- In August of 2022, Council gave approved for staff to begin work on a replacement.
- Due to rising costs and long build-times, the project is being presented ahead of schedule and the need already presents itself.



# Justification

## *Fire Suppression*



## *Recent Development*

- Cielo Apartments
- Altair, Ursa, Aura Apartments
- Axle Apartments
- Willows Bend Senior Living
  - Equates to approximately 3,000 new residents living above a single-story
  - Plan review includes specific factors using Aerial Apparatus calculations

# Justification (cont'd)

*Insurance Considerations*



*Unique Capabilities*



# Process

- Committee of firefighters led by Chief Zikmund
- Four Dealers/Manufacturers solicited
- Site visits to recent deliveries from all four vendors
- Plant visits to two finalists
- Negligible price difference, true choice of features and components
- 30 month build
  - Change orders
  - Loose equipment

# Specification



**FRIDLEY FIRE DEPARTMENT  
FRIDLEY, MN**

QUOTE 123243

AERIAL BODY W/ SIDE STACKER HOSEBED  
E-ONE CYCLONE CHASSIS  
HP100 AERIAL

THIS DRAWING IS FOR REFERENCE PURPOSES. ALL DIMENSIONS ARE SUBJECT TO MINOR VARIATIONS DUE TO MANUFACTURING PROCESSES.

This print is the property of E-ONE, Inc. and is loaned to you subject to return on demand, unless otherwise agreed to in writing by E-ONE, Inc. Its contents are confidential and must not be copied or submitted to third parties for use or examination.

2000 GPM WATEROUS CSU PUMP	HOSE LOAD:
470 GALLON WATER TANK	NFPA CAPACITY
30 GALLON INTEGRAL CLASS "A" FOAM TANK	

COMPT.	OPENING	INTERIOR DIMENSION		
L1/R1	29W 48H	31W 28H	NOTED	UPPER LOWER
L2/R2	37W 62H	39W 19H	NOTED	UPPER LOWER
L3	51W 18H	51W 18H		25D
R3	22W 34H	22W 34H		23D
L4	53W 18H	53W 18H		20D
R4	31W 20H	31W 20H		14D
L5	22W 56H	22W 15H	18D	UPPER LOWER
R5	36W 30H	36W 30H		23D
L6	45W 33H	47W 15H	18D	UPPER LOWER
L7	12W 6H	12W 6H		23D

GROUND LADDERS			
ITEM	LADDER LENGTH	MODEL NUMBER	QTY
A	30' 2-SECT.	PEL-30	2
B	24' 2-SECT.	PEL-24	1
C	18' ROOF	PRL-18	1
D	14' ROOF	PRL-14	2
E	12' ROOF	PRL-12	1
F	10' FOLDING	FL-10	1
G	LITTLE GIANT	MODEL 17	1

ONE ON AERIAL

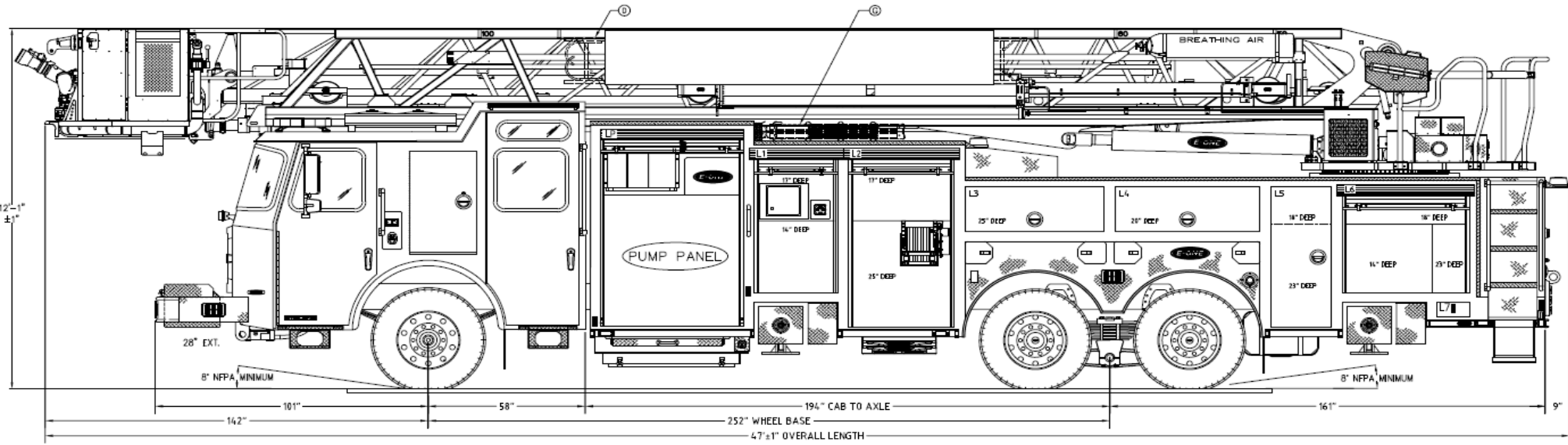
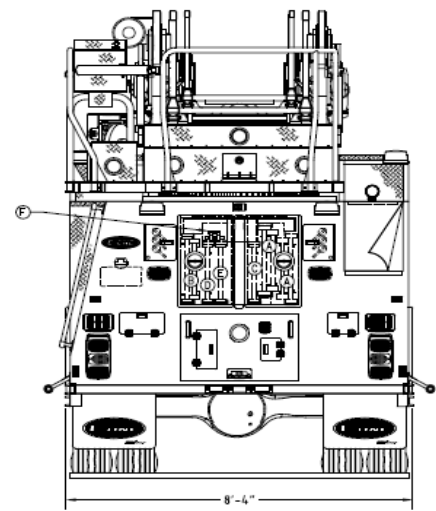

# Thank you!

Questions?

